

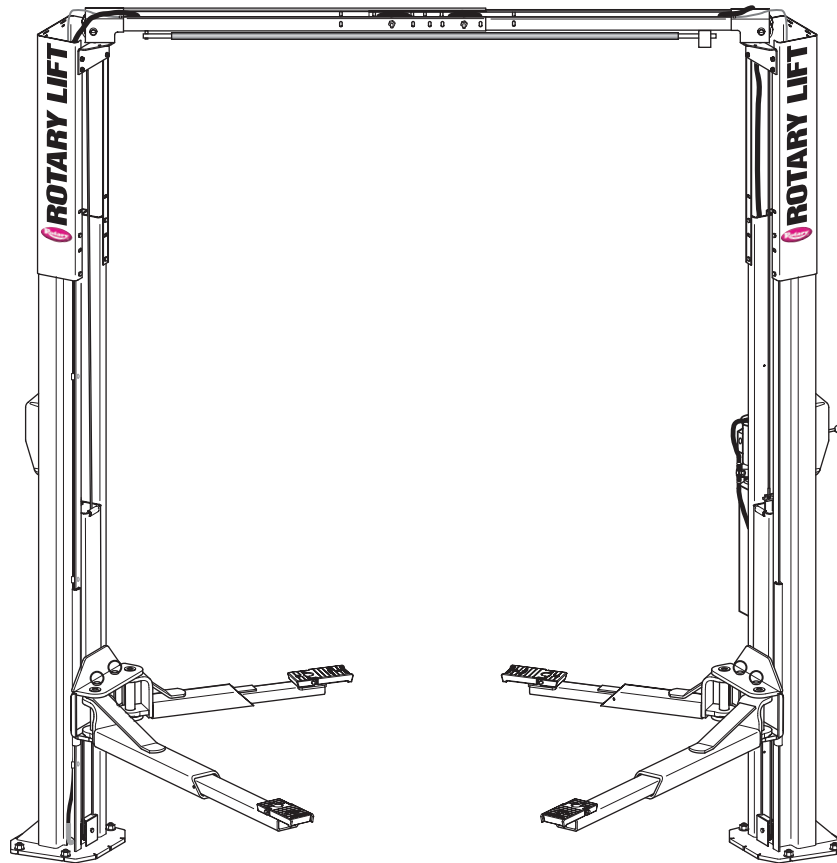

# SPOA10NB, SPOA10, SP010 SPOA7, SPOA9, SP09 (500 And 700 Series Lifts)

SPOA7 Capacity 7,000 lbs.  
SPOA9, SP09 Capacity 9,000 lbs.  
SPOA10NB, SPOA10, SP010 Capacity 10,000 lbs.

**▲ IMPORTANT** Reference ANSI/ALI ALIS, Safety Requirements for Installation and Service of Automotive Lifts before installing lift.



LP20314

I  
N  
S  
T  
A  
L  
L  
A  
T  
I  
O  
N  
  
I  
N  
S  
T  
R  
U  
C  
T  
I  
O  
N  
S

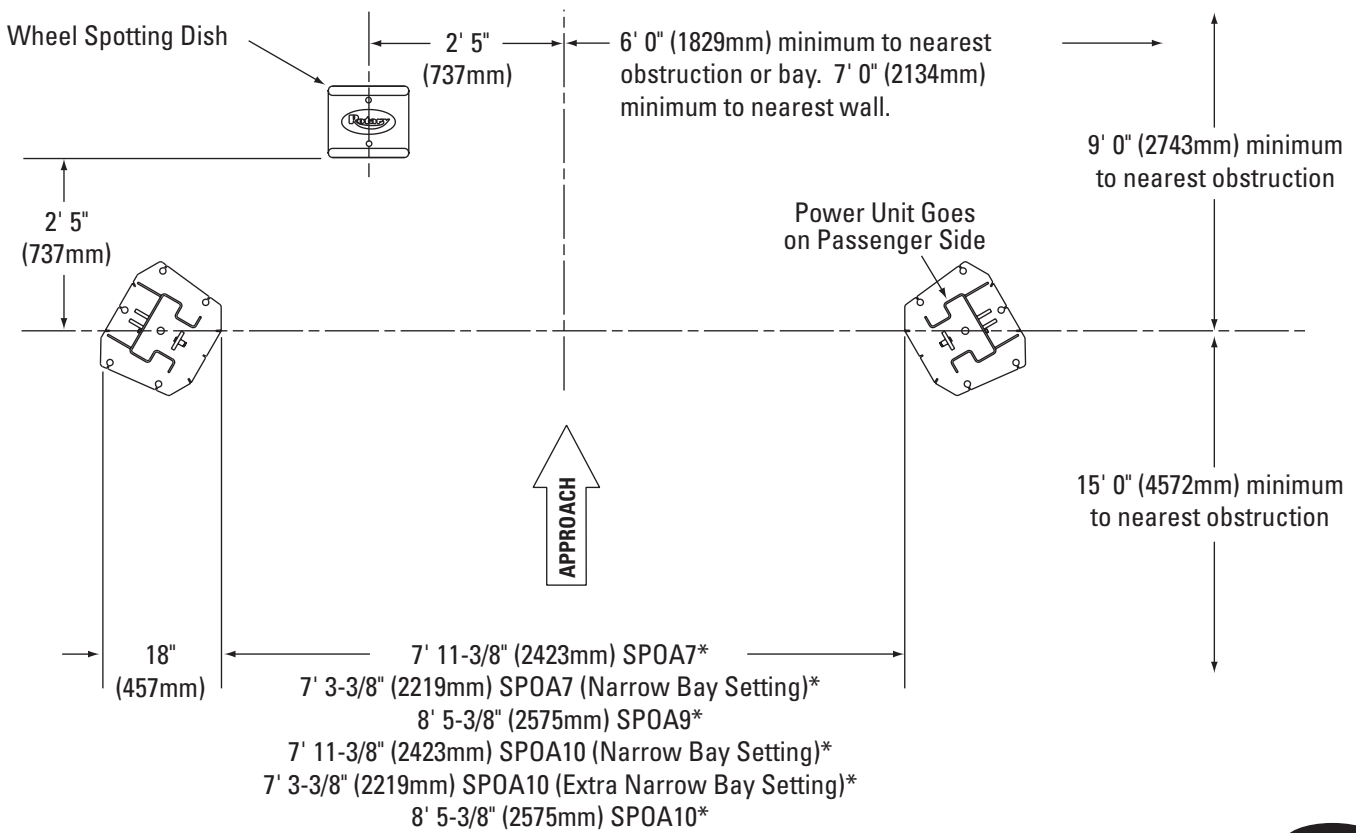

**Fig. 1a**

\*NOTE: Dimension is from Inside of Baseplate to Inside of Baseplate.

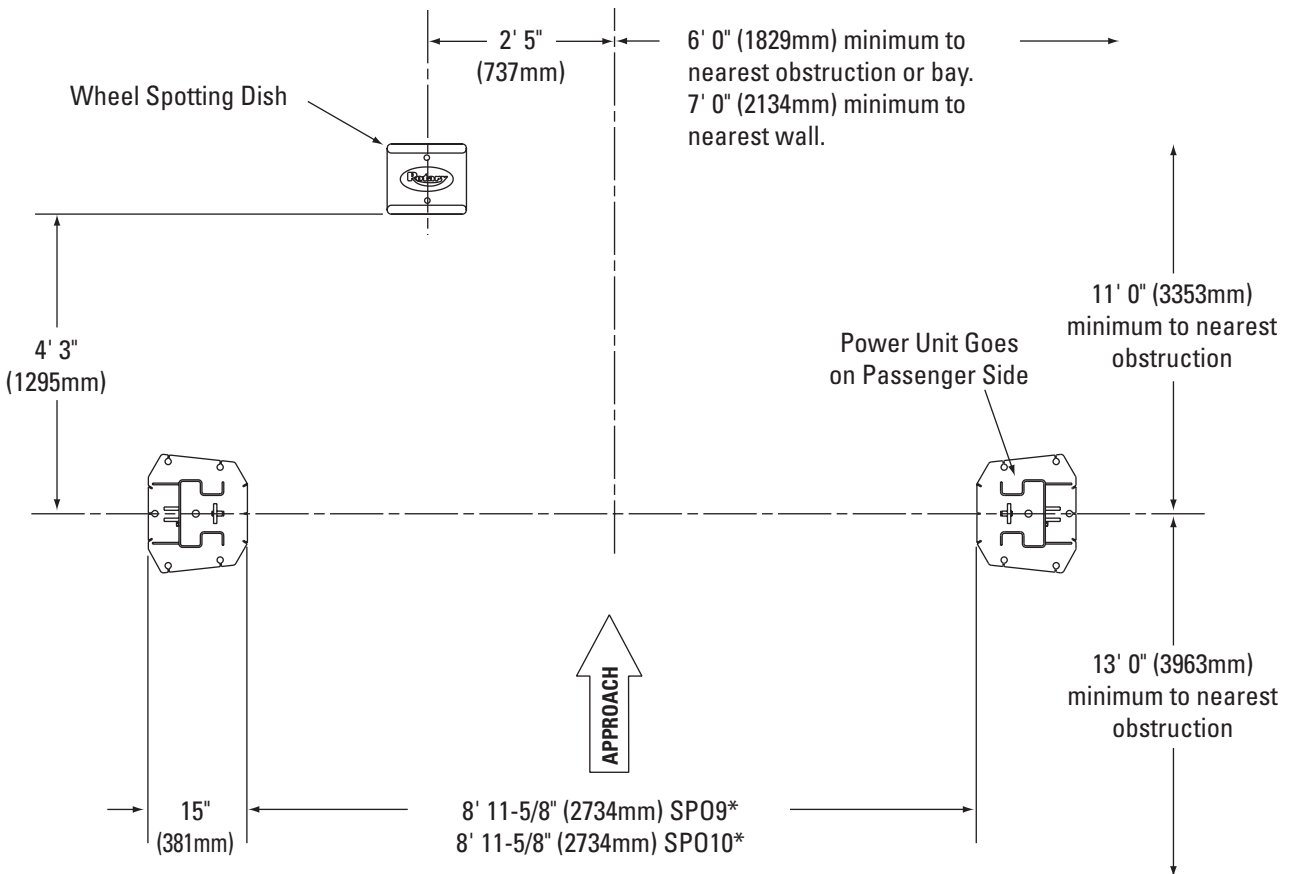

**Fig. 1b**

\*NOTE: Dimension is from Inside of Baseplate to Inside of Baseplate.

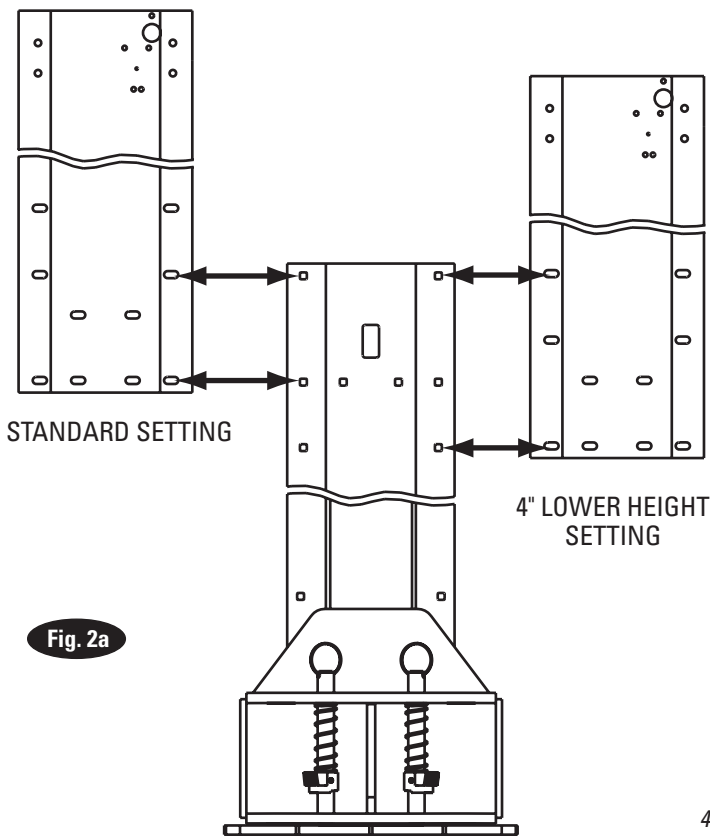

Fig. 2a

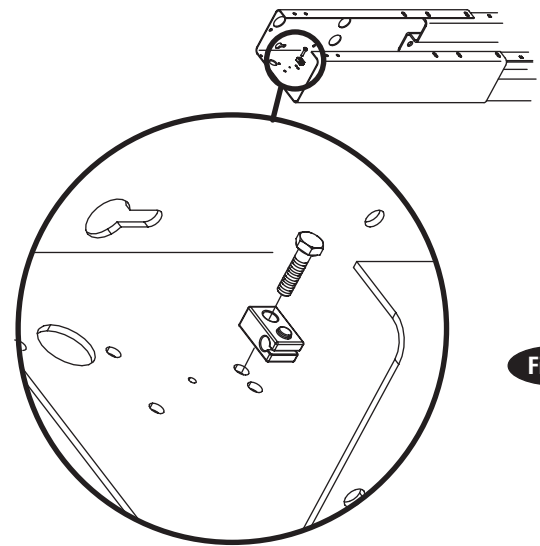

Fig. 2b

**1. Lift Location:** Use architects plan when available to locate lift. Fig. 1a & Fig. 1b shows dimensions of a typical bay layout.

**2. Lift Height:** See Fig. 4 for overall lift height of each specific lift model. Add 1" min. to overall height to lowest obstruction.

**⚠ WARNING DO NOT install this lift in a pit or depression due to fire or explosion risks.**

**3. Column Extensions:** Before standing columns upright, install the column extensions using (12) 3/8"-16NC x 3/4" Carriage HHCS and Flanged Locknuts, Fig. 4, and Fig. 2a.

**4. Latch Cable Guides:** Install the latch cable conduit guide brackets to column extensions with (1) 1/4"-20NC x 1" HHCS and 1/4"-20NC Flanged Locknuts, Fig. 2. HHCS should go through hole nearest the edge as shown, Fig. 2b.

**5. Overhead Mounting Bracket:** Install Mounting Brackets to column extensions as shown, Fig. 4.

**6. Lift Setting:** Position columns in bay using dimensions shown in Fig. 1a & Fig. 1b. Place column with power unit mounting bracket on vehicle passenger side of lift. Both column base plate backs must be square on center line of lift. Notches are cut into each base plate to indicate center line of lift. Use appropriate equipment to raise carriage to first latch position. Be sure locking latch is securely engaged.

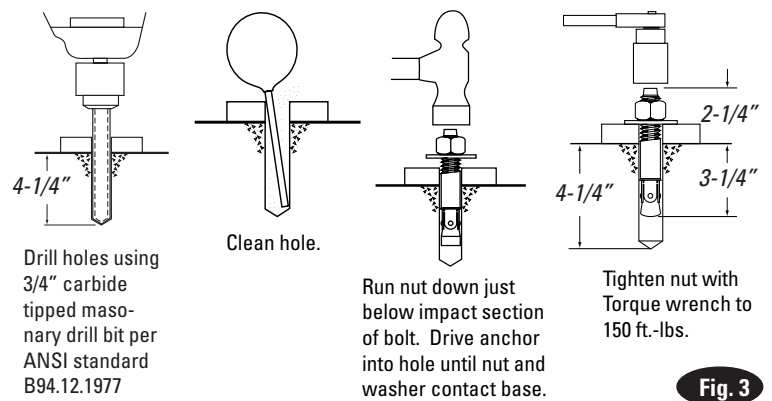

Fig. 3

**Installation torque of 150 ft.-lbs. is required for all anchor bolts.**

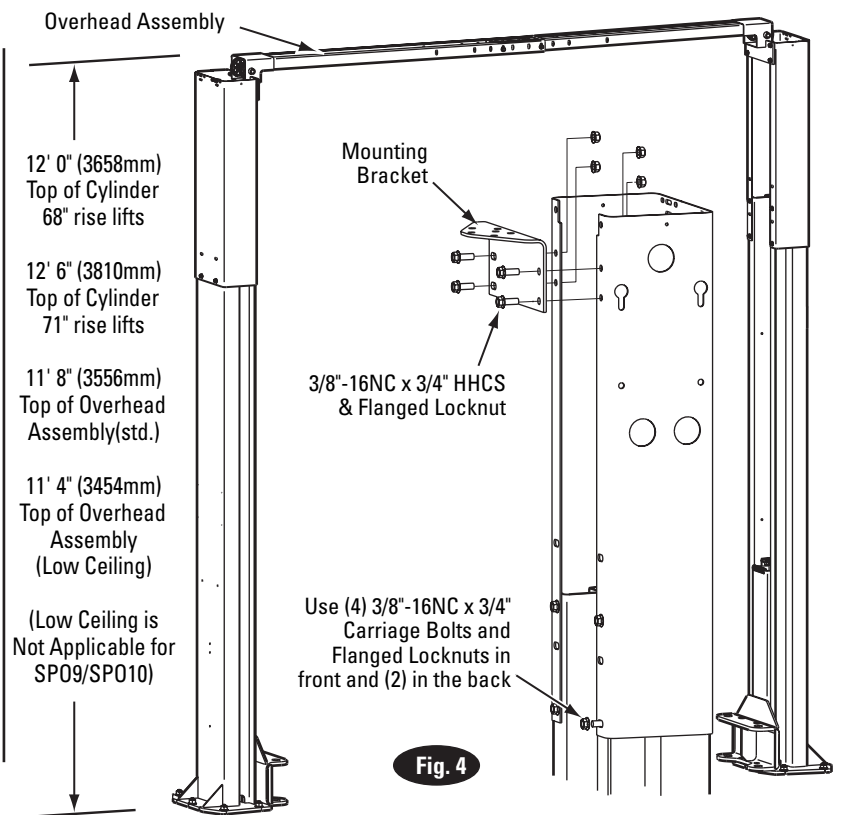
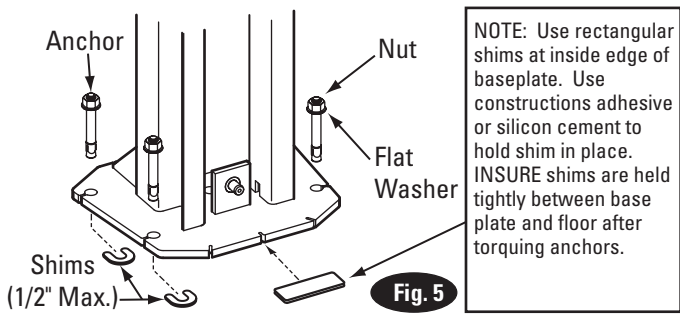

Fig. 4



**NOTE:** Use rectangular shims at inside edge of baseplate. Use construction adhesive or silicon cement to hold shim in place. INSURE shims are held tightly between base plate and floor after torquing anchors.

**NOTE:** If more than 2 horse shoe shims are used at any of the column anchor bolts, pack non-shrink grout under the unsupported area of the column base. Insure shims are held tightly between the baseplate and floor after torquing anchors.

**Concrete and Anchoring:**

Concrete And Anchoring Requirements
Floor Requirements: Minimum 3000 PSI concrete
Optimum Floor Thickness: 5-1/2" -6"
Minimum Floor Thickness: 4-1/4"
Minimum Anchor Embedment: 3-1/4"
Maximum Anchor Exposure Floor Grade to Top of Anchor: 2-1/4". Exposure greater than 2-1/4" NOT ACCEPTABLE.
Note: Hilti Kwik Bolt III™ anchors are provided for standard installation the minimum distance you can install them to an edge, expansion joint, or abandoned anchor hole is 4-1/2".
<b>For installations not meeting these requirements or for seismic anchor information contact customer service at: 800.445.5438</b>

Drill (10) 3/4" dia. holes in concrete floor using holes in column base plate as a guide. See Fig. 3 for hole depth, hole spacing, and edge distance requirements.

**CAUTION** DO NOT install on asphalt or other similar unstable surfaces. Columns are supported only by anchors in floor.

**IMPORTANT** Using the horse shoe shims provided, shim each column base until each column is plumb. If one column has to be elevated to match the plane of the other column, full size base shim plates should be used (Reference FA5112 Shim Kit). Recheck columns for plumb. Tighten anchor bolts to an installation torque of 150 ft-lbs. Shim thickness MUST NOT exceed 1/2" when using the 5-1/2" long anchors provided with the lift, Fig. 5. Adjust the column extensions plumb.

If anchors do not tighten to 150 ft-lbs. installation torque, replace concrete under each column base with a 4' x 4' x 6" thick 3000 PSI minimum concrete pad keyed under and flush with the top of existing floor. Let concrete cure before installing lifts and anchors.

**7a. Overhead Assembly:** Fig. 11: Adjust overhead to appropriate dimension. Install (4) 3/8"-16NC x 3/4" HHCS & 3/8"-16NC Flanged Locknuts, do not tighten. Slide Switch Box over switch bar ensuring knock out holes face the power unit column. Use (2) 1/4"-20NC x 3/4" lg. HHCS, 1/4"-20NC Nuts and 1/4" Star Washers to mount switch box to overhead, see Fig. 7. For SPOA10 Extra Narrow Bay Setting installation, see step 7b, all others go to step 7c.

**7b. For Extra Narrow Bay installation only:** Cut off 11" from the length of the bar and cushion on the end opposite the 1/4" mounting hole(s). Continue to step 7c.

**7c. Continued Overhead Assembly:**

**For single phase lifts:** Insert 1/4"-20NC x 2-3/4" HHCS through pivot hole in end of switch bar. Insert opposite end of bar through slot in switch mounting bracket. Then secure HHCS and Switch Bar to overhead as shown, Fig. 11, using (2) 3/4" spacers and 1/4"-20NC Locknut. Tighten Hex bolt leaving 1/16" gap between the spacer and the overhead assembly.

**For three phase lifts:** Remove Limit Switch cover, Fig. 8. Insert Actuator end of Switch Bar into slot located inside Limit Switch, Fig. 8. A small amount of silicone sealant on the lower part of the actuator will help hold it in place. Insert 1/4"-20NC x 2-3/4" HHCS through pivot hole in end of Switch Bar. NOTE which hole to use, Fig. 11. Then secure HHCS and Switch Bar to overhead as shown, using (2) 3/4" spacers and 1/4"-20NC Locknut. Tighten Hex bolt leaving 1/16" gap between the spacer and the overhead assembly, Fig. 11. Replace limit switch cover.

**8. Overhead Installation:** Install overhead assembly to Mounting Bracket with (2) 3/8"-16NC x 3/4" Flanged HHCS, (2) 3/8"-16NC Flanged Locknut, and (2) 3/8" star lockwashers, Fig. 6. Use middle holes for SPO9/SPO10 and outside holes (marked L for Left and R for Right) for SPOA9/SPOA10NB/SPOA10. Tighten bolts at center of overhead assembly.

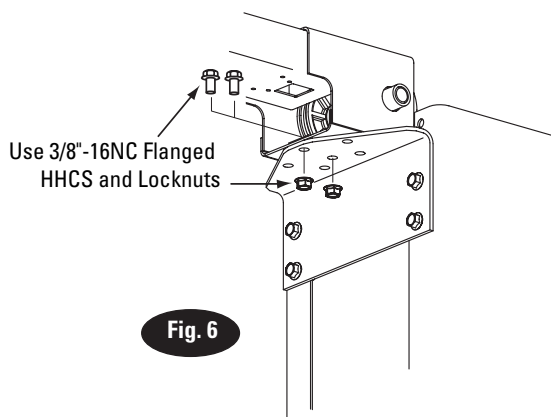

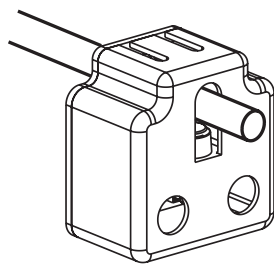
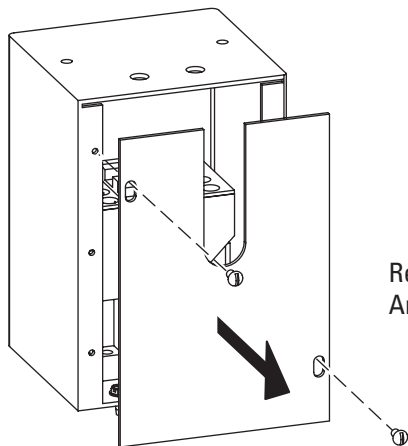

Fig. 7



Remove Screws  
And Cover

Fig. 8

Place Actuator Here.  
A Small Amount Of Silicone Sealant  
On The Lower Part Of The Actuator  
Will Help Hold It In Place.

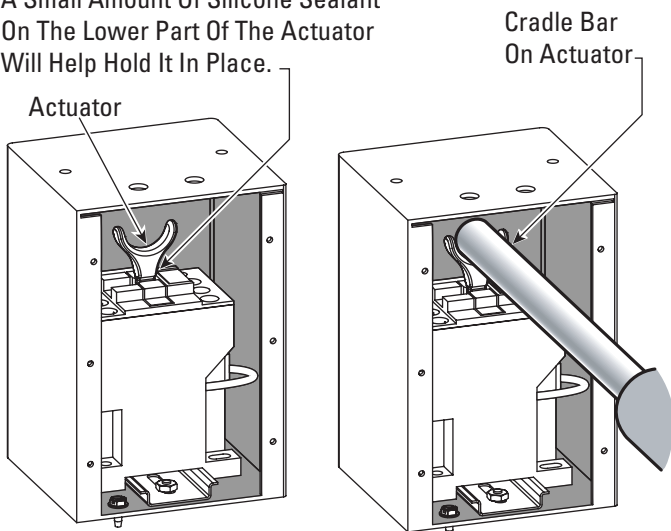

Cradle Bar  
On Actuator

Actuator

**9. Power Unit:** First install (1) star washer onto one of the (4) 5/16" -18NC x 1-1/2" HHCS. *This is very important for grounding.* Put the (4) 5/16" -18NC x 1-1/2" HHCS thru holes in power unit bracket using Push-Nuts to hold in place, Fig. 9. Mount unit with motor up to column bracket and install (4) 5/16" star washers and 5/16" Nuts. Install and hand tighten Branch Tee to pump until O-ring is seated. Continue to tighten the locknut to 10-15 ft-lbs., or until the nut and washer bottom out against the pump manifold. **NOTE:** You may still be able to rotate the Branch Tee. This is acceptable unless there is seepage at the O-ring. If so, slightly tighten the locknut.

**CAUTION** Over tightening locknut may tear O-ring or distort threads in pump manifold outlet.

**10. Hoses:** Clean adapters and hose. Inspect all threads for damage and hose ends to be sure they are crimped, Fig. 10. Install hose and hose clamps, Fig. 12 & Fig. 16.

#### Flared Fittings Tightening Procedure

1. Screw the fittings together finger tight. Then, using the proper size wrench, rotate the fitting 2-1/2 hex flats.

**IMPORTANT** Flare seat **MUST NOT** rotate when tightening. Only the nut should turn.

2. Back the fitting off one full turn.  
3. Again tighten the fittings finger tight; then using a wrench, rotate the fitting 2-1/2 hex flats. This will complete the tightening procedure and develop a pressure tight seal.

**CAUTION** Overtightening will damage fitting resulting in fluid leakage.

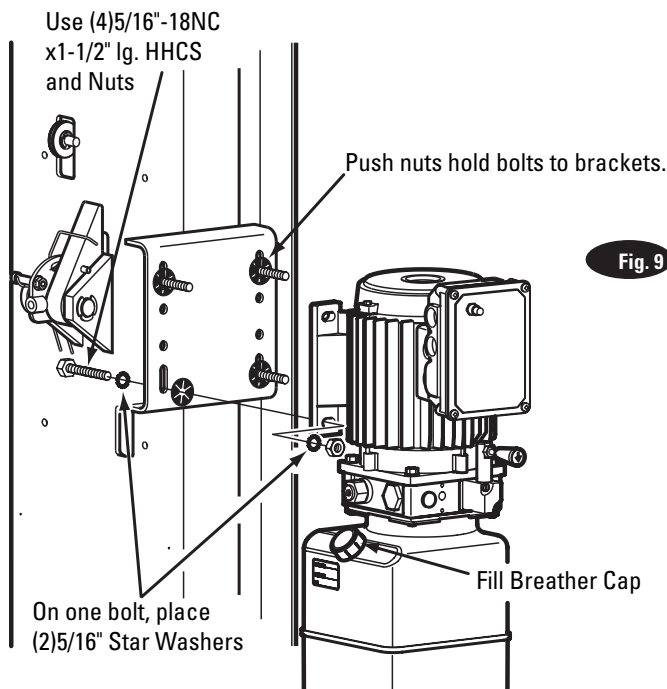

Fig. 9

Use (4) 5/16" -18NC  
x1-1/2" lg. HHCS  
and Nuts

Push nuts hold bolts to brackets.

On one bolt, place  
(2) 5/16" Star Washers

Fill Breather Cap

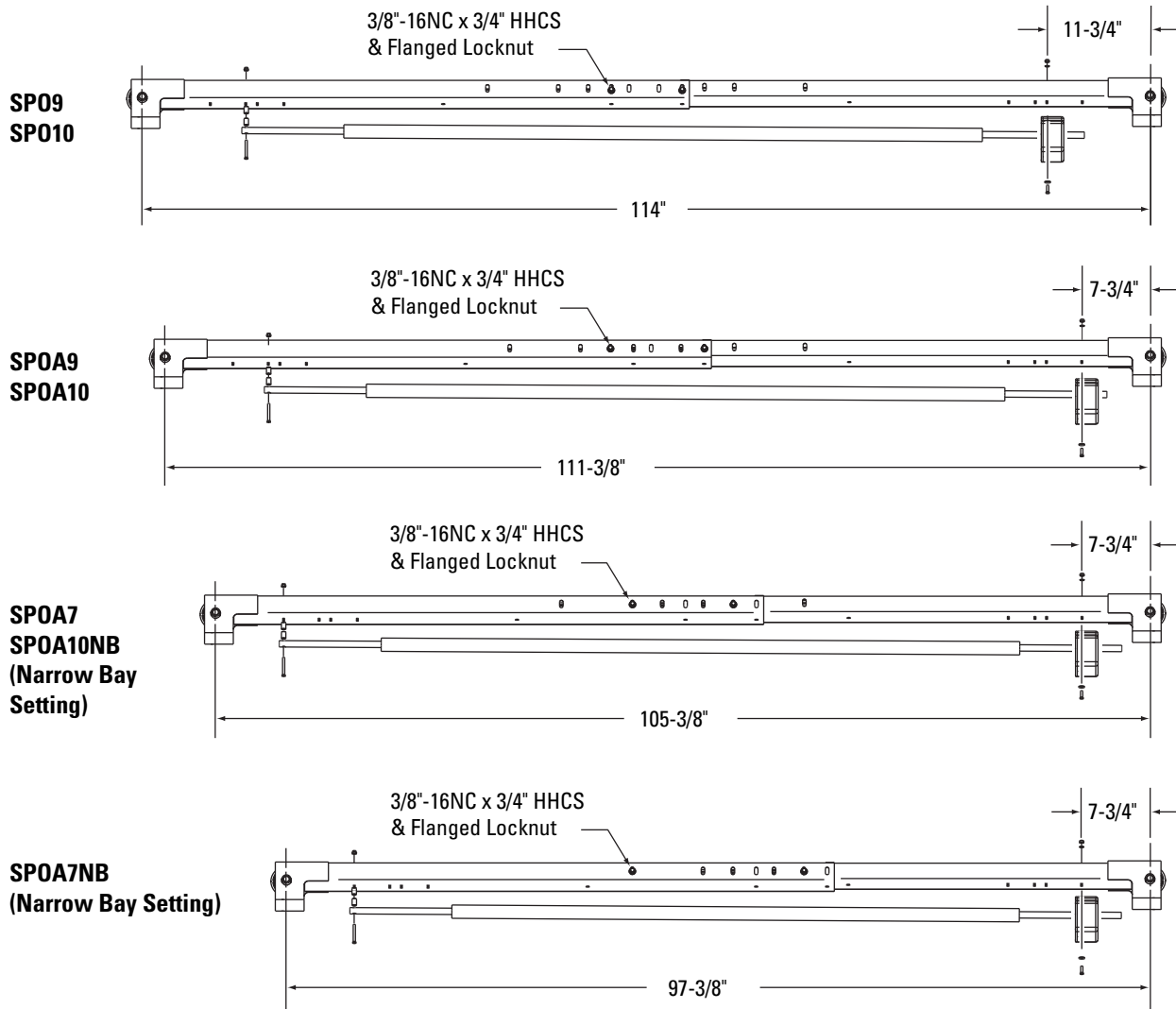

Hardware Detail For Overhead Assembly

Fig. 11

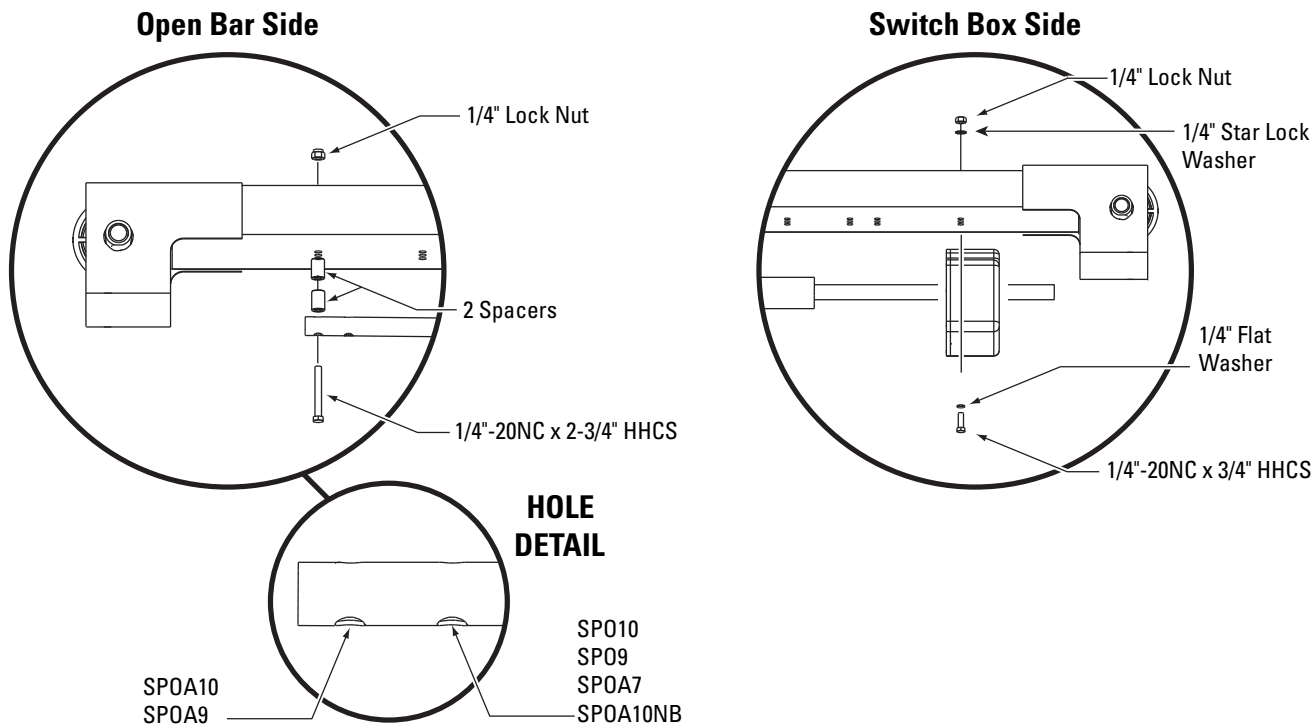

## Adapter & Hose Installation (see Fig. 12)

1. Install Pc. (2) with hose clamps, on power unit column side connecting it to the cylinder (1) first.
2. Install Pc. (3) with hose clamps starting at left column cylinder (5) and working toward the right column. All excess hose should be at bends & inside overhead assembly. **DO NOT try to use optional column extension mounting holes, Fig. 2a, when attaching hose clamps. They will NOT work. Use lower set of holes.**
3. Install Pc. (4) into power unit.
4. Connect Pc. (2) & Pc. (3) to Tee (4).

**NOTE:** Route Power Unit hose inside columns using slots provided at column base, Fig. 14. Route Overhead Hose in column channel on outside of column, Fig. 14. Overhead hose goes over top end of overhead assembly, Fig. 12 & Fig. 16a & Fig. 16b.

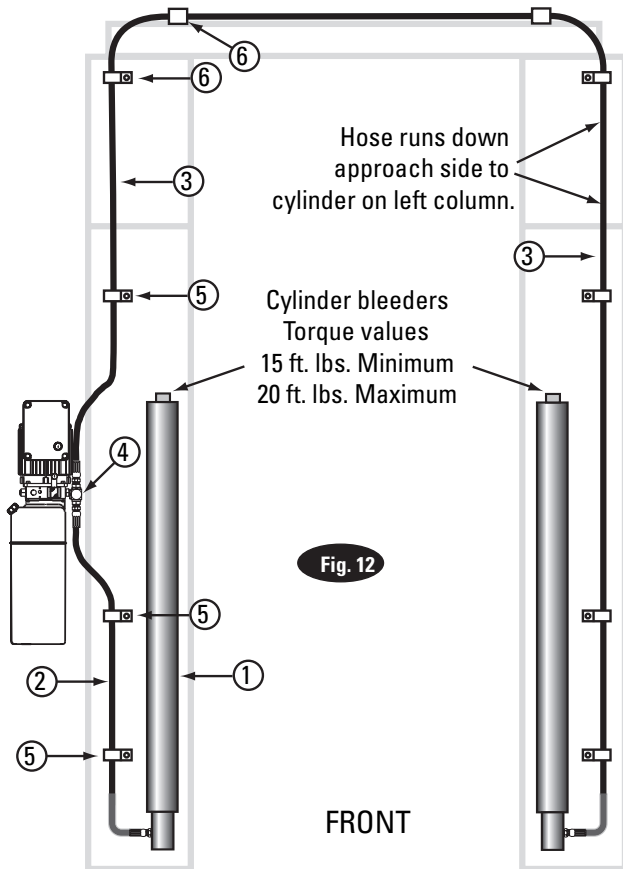

Fig. 12

ITEM	QTY.	DESCRIPTION
1	2	Hydraulic Cylinder
2	1	Power Unit Hose
3	1	Overhead Hose
4	1	Branch Tee
5	6	Hose Clips
	6	3/8"-16NC x 3/4" Ig. Carriage Bolts
	6	3/8"-16NC Flanged Locknuts
6	4	Hose Clips
	4	3/8"-16NC x 3/4" Ig. Flanged HHCS
	4	3/8"-16NC Flanged Locknuts

## 11. Equalizing Cables

- Refer to Fig. 13 for the general cable arrangement. First, run a cable end up through the small hole in the lower tie-off plate. Fig. 15.
- Push the cable up until the stud is out of the carriage top opening.
- Run a nylon insert locknut onto the cable stud so 1/2" (13mm) of the stud extends out of the locknut.
- Pull the cable back down, Fig. 15.
- Run cable around the lower sheave, then up and around overhead sheave and across and down to the opposite carriage, Fig. 13. Install sheave cover, Fig. 14.
- Fasten the cable end to the carriage upper tie-off bracket, Fig. 15. Tighten the locknut enough to apply light tension to the cable.
- Repeat procedure for the second cable. Complete lift assembly. Adjust the tension of both cables during the final adjustments in Paragraph 21.

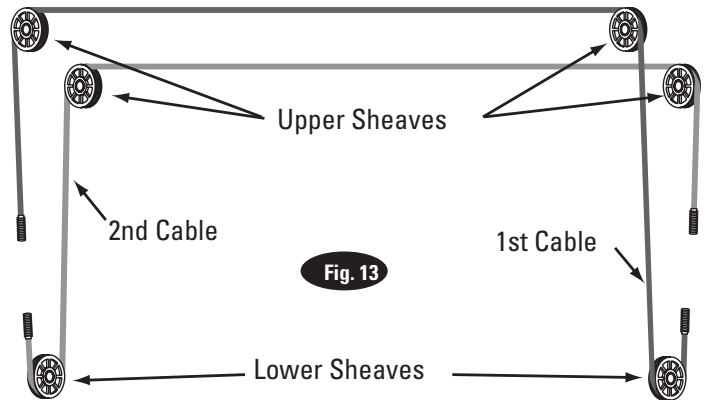

Fig. 13

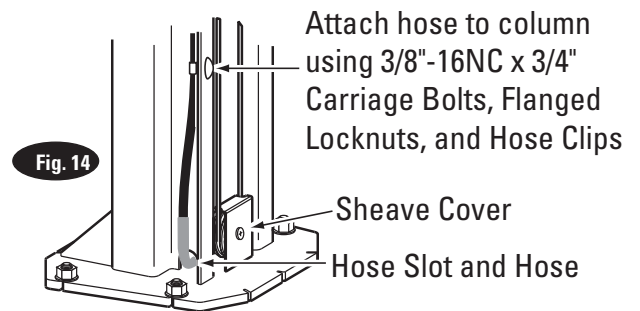

Fig. 14

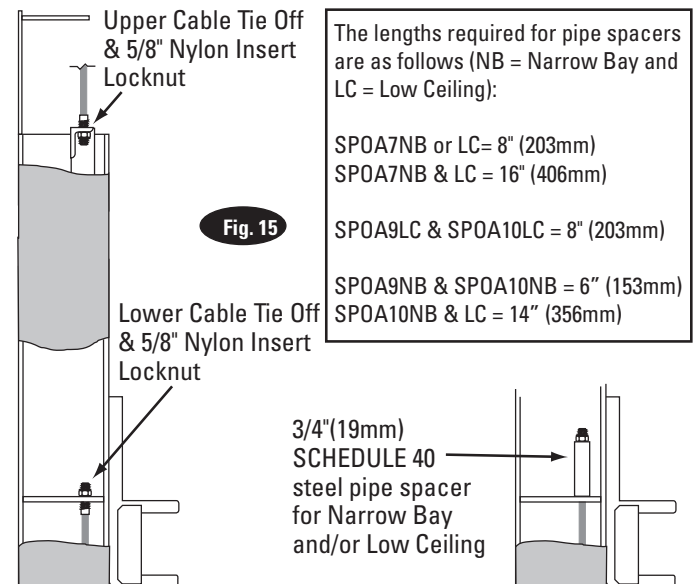

Fig. 15



## 12. Locking Latch Cable

- A) Install latch cable sheave and retaining rings in upper slot of power unit column as shown, Fig. 17.
- B) Slip loop end of cable over end of shoulder screw on right side latch control plate, Fig. 17.
- C) Feed the other end of the cable through the latch cable sheave slot making sure that the cable is running under the bottom side of the latch cable sheave and inside the right column, Fig. 17.
- D) Attach latch cable conduit guide brackets to overhead as shown, Fig. 16a & Fig. 16b. Always use the holes on the approach side of the lift. HHCS should be in hole nearest the center of the overhead, Fig. 16b.
- E) Route cable up inside column and through the latch cable guide, Fig. 16a & Fig. 18.

**IMPORTANT** Using wire ties provided, tie off cable guide to column extension as shown, Fig. 16a. Guide must be attached in hole closest to the outside edge of the column on the NON-APPROACH side.

- F) Continue routing cable to the left column latch cable guide, Fig. 16a & Fig. 18, routing the cable through the left column latch cable guide, Fig. 16a.

**IMPORTANT** Using wire ties provided, tie off cable guide to column extension as shown, Fig. 16a. Guide must be attached in hole closest to the outside edge of the column on the NON-APPROACH side.

- G) Bring the cable down inside the left column and feed the end of the cable through the lower latch cable sheave slot so that the cable is now back outside the column, Fig. 19.
- H) Install latch cable sheave and retaining rings in lower slot of non-power unit column as shown, Fig. 19.

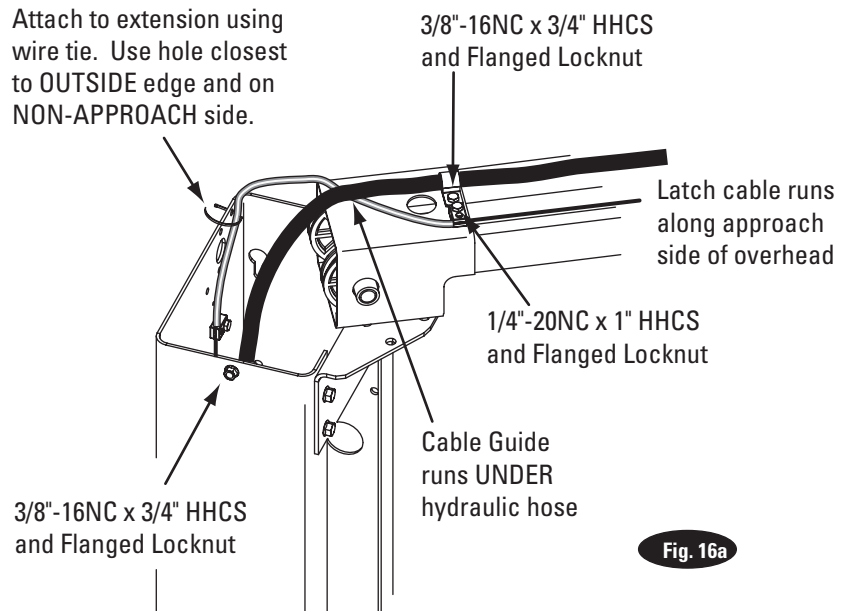

- I) Route cable under the bottom side of the latch cable sheave, Fig. 19.
- J) At this point you MUST install the latch handle, jam nut, and right column latch cover Fig. 17 & Fig. 20. Install latch handle ball, Fig. 20.
- K) Insert cable in cable clamp along one side, loop around shoulder screw and back down, inserting cable along other side of cable clamp, Fig. 19. Place top back on clamp, barely tightening.
- L) Next, pull the control plate down, Fig. 18 & Fig. 19, to eliminate any clearance between the control plate slot and the latch dog pin, Fig. 18.
- M) Using Pliers, pull cable tight and secure the clamp close to the shoulder screw. Tighten clamp.

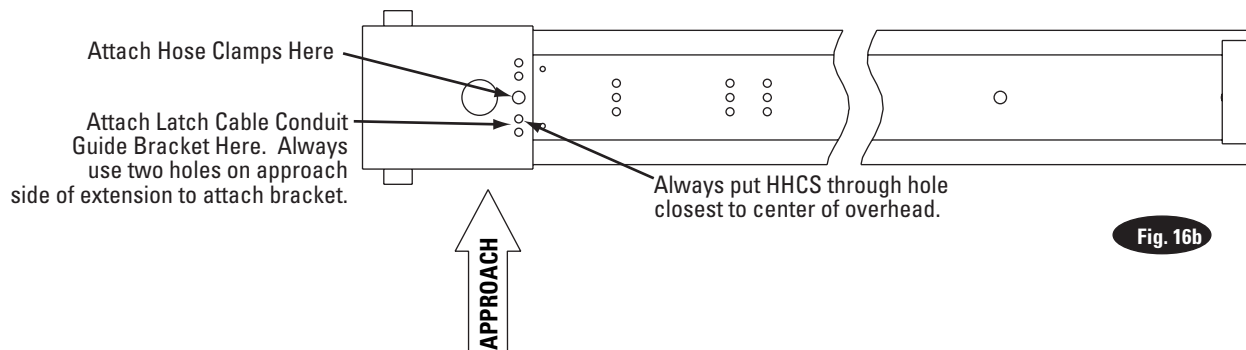



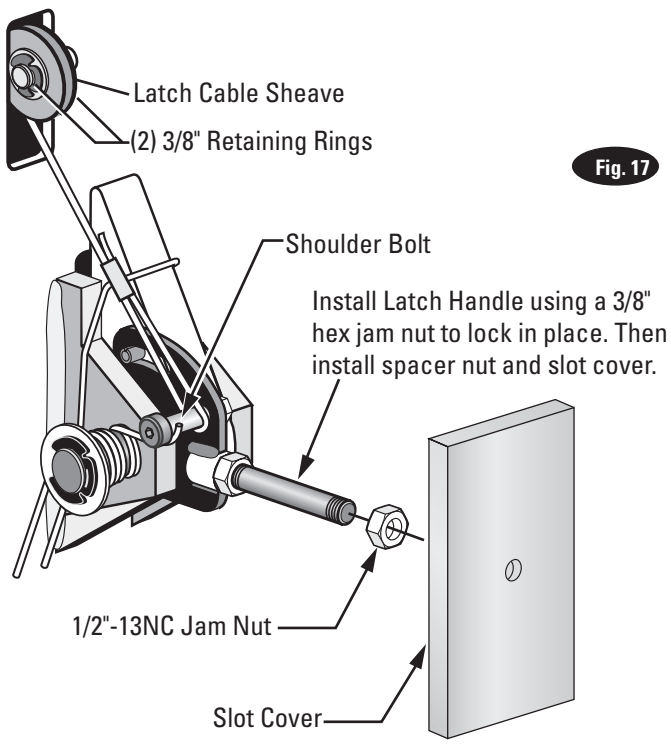

Fig. 17

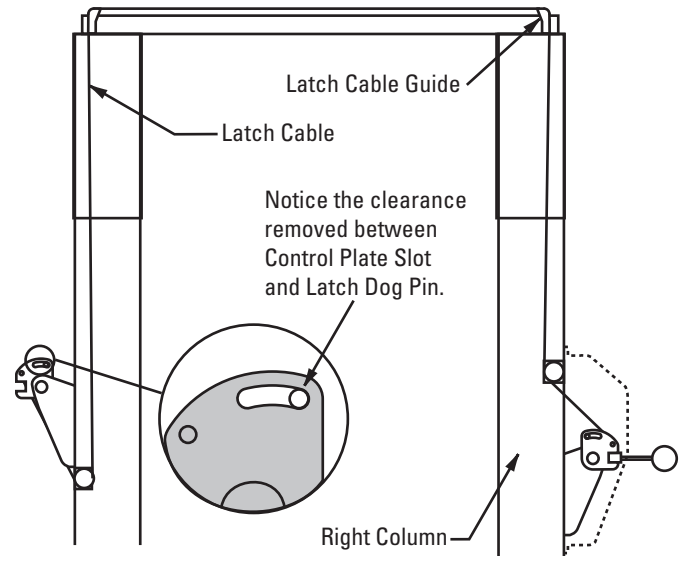

Fig. 18

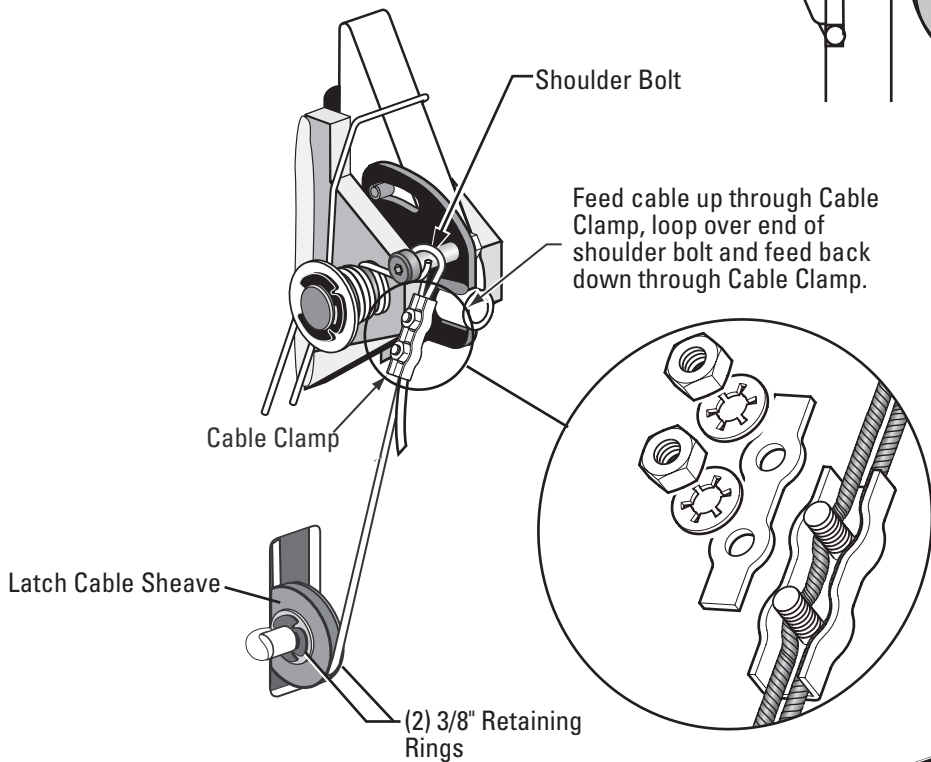

Fig. 19

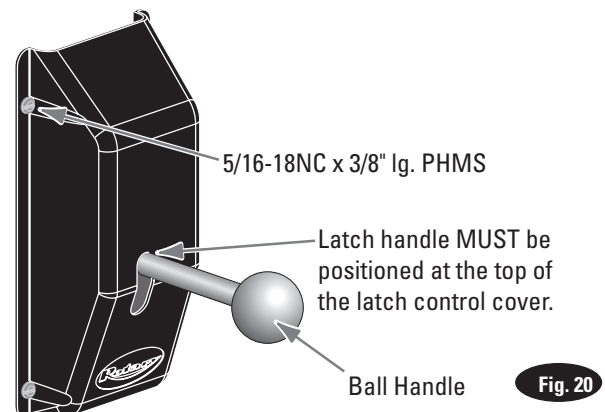

Fig. 20

**13. Electrical:** Have a certified electrician run appropriate power supply to motor, Fig. 21 & 22. Size wire for 20 amp circuit. See Motor Operating Data Table.

**CAUTION** Never operate the motor on line voltage less than 208V. Motor damage may occur.

**IMPORTANT:** Use separate circuit for each power unit. Protect each circuit with time delay fuse or circuit breaker. For single phase 208-230V, use 20 amp fuse. Three phase 208-240V, use 20 amp fuse. For three phase 400V (\*E Model) and above, use 10 amp fuse. For three phase 380V (\*S Model) use 16 amp fuse. For wiring see Fig. 22 & Fig. 23. All wiring must comply with NEC and all local electrical codes.

**Note:** 60Hz. single phase motor **CAN NOT** be run on 50Hz. line without a physical change in the motor.

### Single Phase Power Unit

MOTOR OPERATING DATA TABLE - SINGLE PHASE	
LINE VOLTAGE	RUNNING MOTOR VOLTAGE RANGE
208-230V 50Hz.	197-253V
208-230V 60Hz.	197-253V

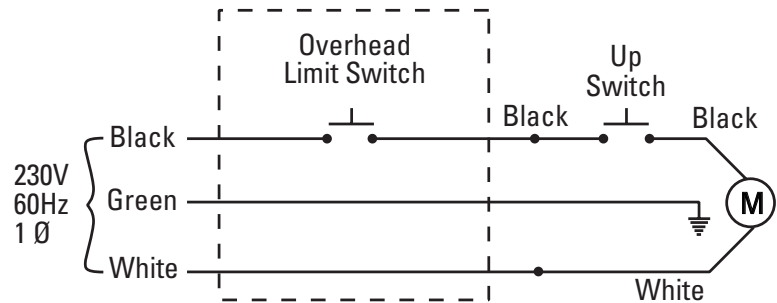

**Note:** 60Hz. Single phase motor **CAN NOT** be run on 50Hz. line without a physical change in the motor.

**NOTE:** Assure cord used for connection between the overhead switch and power unit is of the type specified in:

UL201, Sections 10.1.1.3 & 10.1.1.4

(Example: SO, G, STO) Size for 25 amp circuit. See UL 201, Section 15 for proper wiring requirements for this connection.

Fig. 21

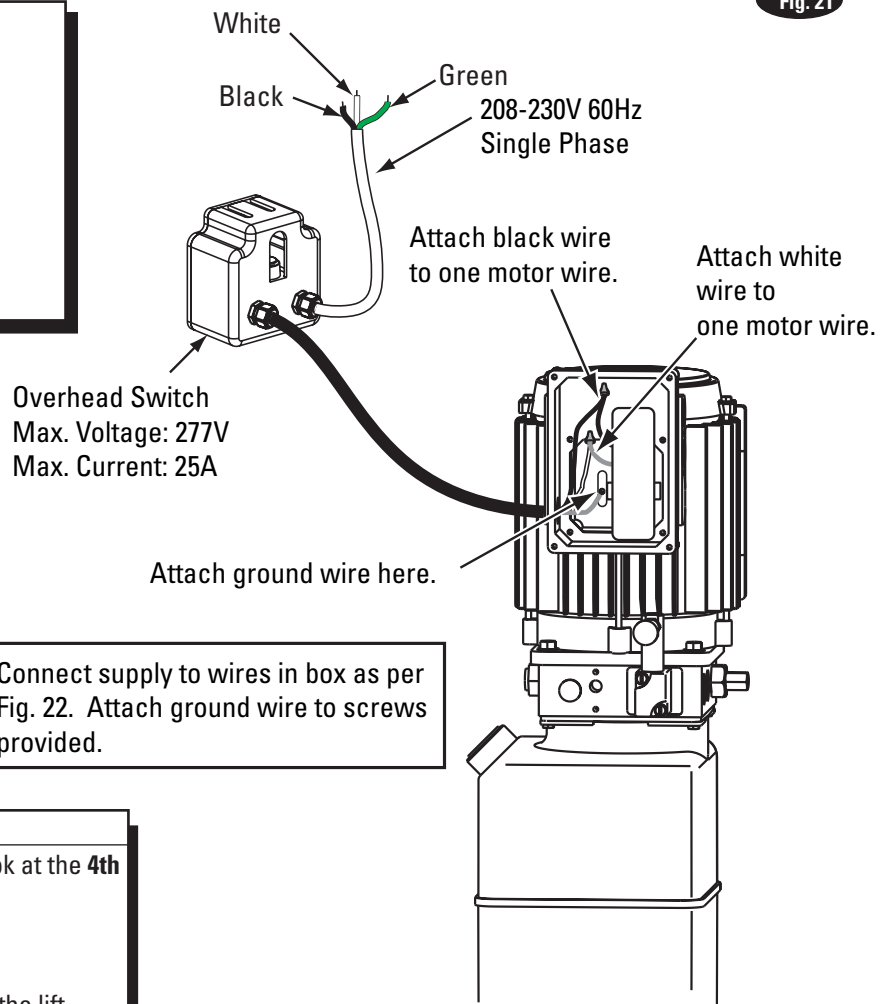

**\*Notes: E or S Model?**

To find out if you have a **E or S** model Power Unit look at the **4th letter from the end** of your lift model number.

EXAMPLE: SPOA10**E**585 would be a **E Model**.



Model number can be found on a tag on the side of the lift.

**NOTE: Two Different Drum Switches were used please select one of the two options below.**

**NOTES:**

1. Unit not suitable for use in unusual conditions. Contact Rotary for moisture and dust environment duty unit.
2. Control Box must be field mounted to power unit.
3. Motor rotation is counter clockwise from top of motor.

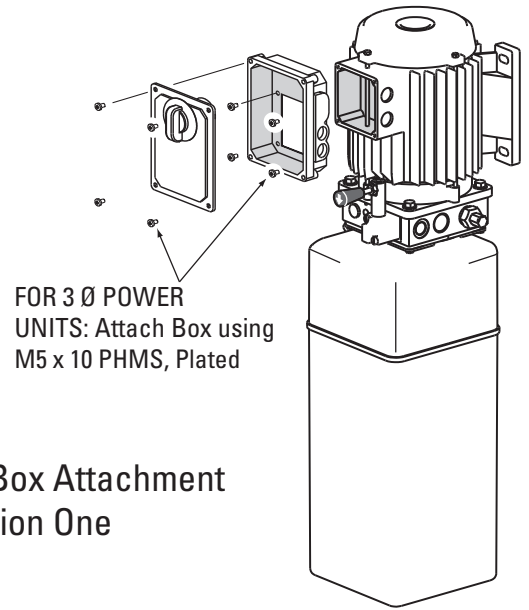
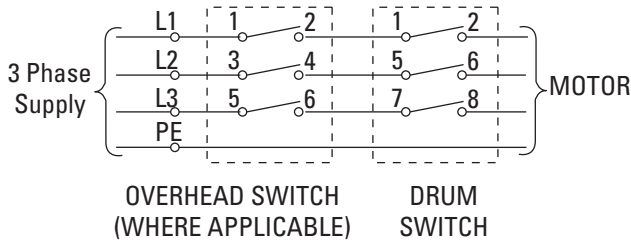

**Fig. 22**

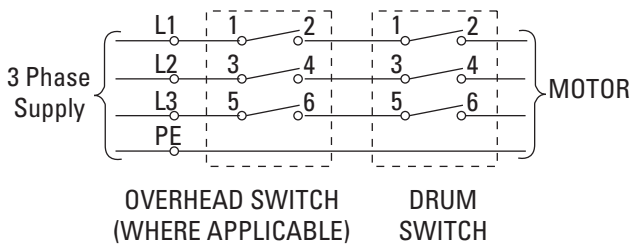
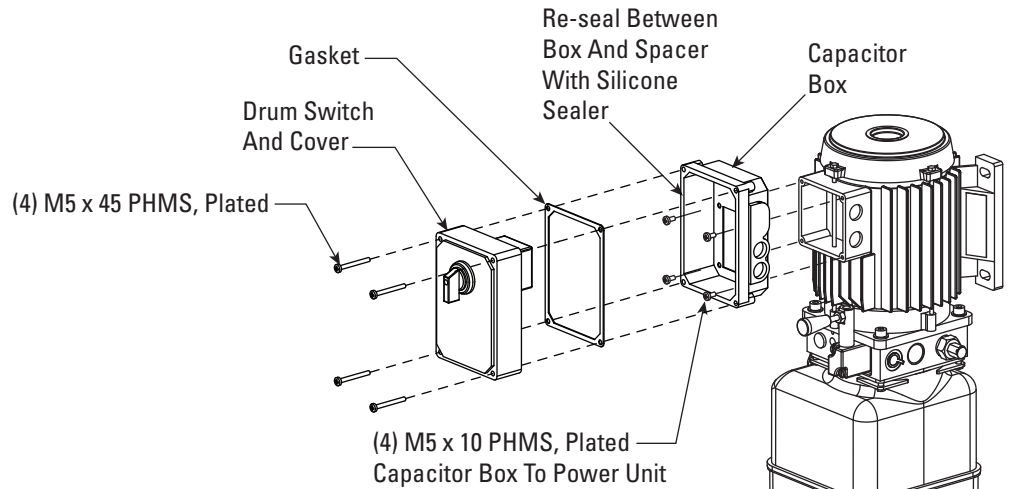

Capacitor Box Attachment Option Two

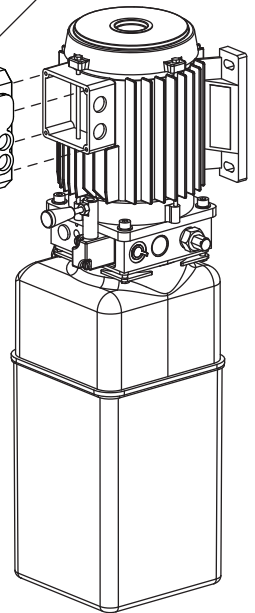

**Three Phase Power Unit**

MOTOR OPERATING DATA TABLE - THREE PHASE	
LINE VOLTAGE	RUNNING MOTOR VOLTAGE RANGE
208-240V 50/60Hz.	197-253V
400V 50Hz.	360-440V
440-480V 50/60Hz.	396V-528V
575V 60Hz.	518V-632V

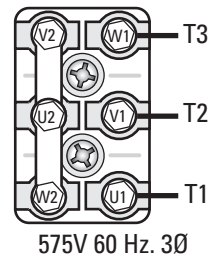
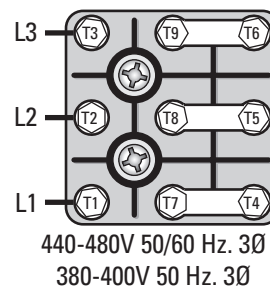
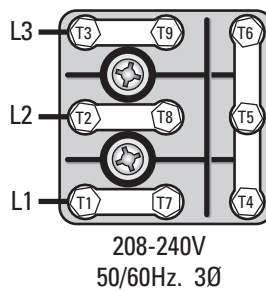

**14. Oil Filling & Bleeding:** Use Dexron III ATF, or Hydraulic Fluid that meets ISO 32 specifications. Remove fill-breather cap, Fig. 10. Pour in (8) quarts of fluid. Start unit, raise lift about 2 ft. Open cylinder bleeders approximately 2 turns, Fig. 12.

Close bleeders when fluid streams. Torque values for the bleeders are 15 ft. lb. minimum and 20 ft lb. maximum. Fully lower lift. Add more fluid until it reaches the MIN \_\_\_\_\_ mark on the tank. Replace fill-breather cap.

**CAUTION** If fill-breather cap is lost or broken, order replacement. Reservoir must be vented.

**15. Overhead switch:** Check overhead switch assembly to assure that switch bar is depressing switch plunger sufficiently to actuate the switch. The overhead switch is wired normally open, see Fig. 21 & Fig. 22. Lift will not operate until weight of switch bar is depressing switch plunger. Verify that Power Unit stops working when switch bar is raised, and re-starts when the bar is released.

**16. Arms & Restraints:** Before installing arms, raise carriages to a convenient height. Grease swivel arm pins and holes with Lithium grease. Slide arm into yoke, Fig. 23a. Install 1-3/4" diameter arm pin(s), Fig. 23a.

After installing arms and pins, install arm Restraint Gears as follows: Install Restraint Gear onto arm clevis, as shown, Fig. 23b. Ensure side of gear marked **TOP** is facing upward, Fig. 23b.

**NOTE:** **TOP** is stamped on top side of gear. You may need to pull up on the pin-ring to allow enough room to install Restraint Gear.

**Arms With 5 Holes In Bearing Bar:** Then, install the (2) 3/8"-16NC x 1-1/2" HHCS (8 total for all 4 arms) and 3/8" Spring Lock washers into the gear and arm, but do not tighten. Reference Fig. 23c, Fig. 24a, and Fig. 24b.

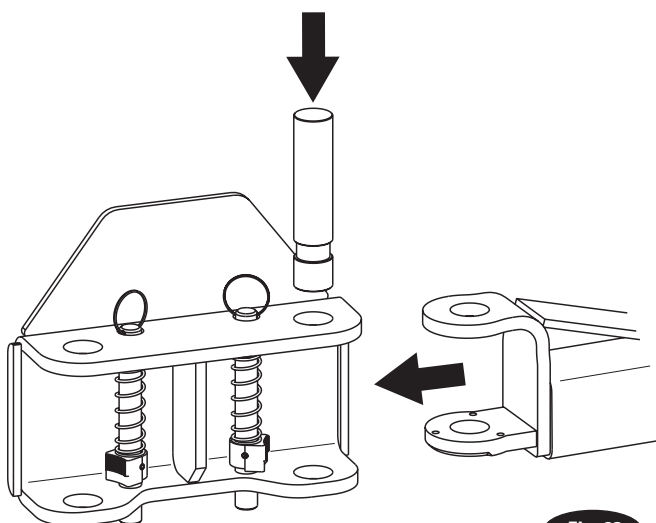
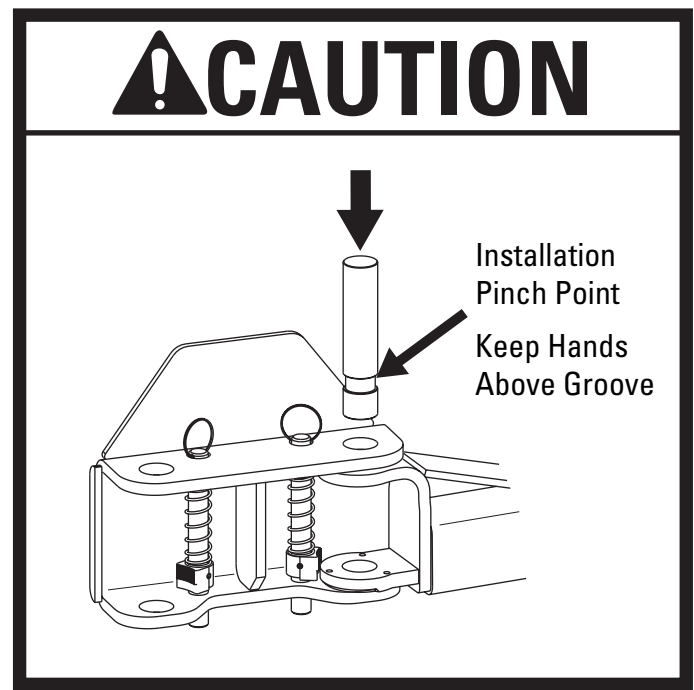

Fig. 23a



**Arms With 3 Holes In Bearing Bars:** Then, install the (2) 3/8"-16NC x 1-1/2" Lg. HHCS ((8) total for all (4) arms) into the gear and arm. Using 3/8" hex jam nuts, secure restraint gears to arms. Reference Fig. 23c and Fig. 24b.

Torque the Restraint Gear bolts to 30-34 ft.-lbs.

**NOTE:** Once arm is installed in yoke, pull up actuator pin and swing arm fully around, being sure that the Restraint Gear and Gear Block always stay aligned. If they do not stay aligned, remove restraint gear and install in the opposite position.

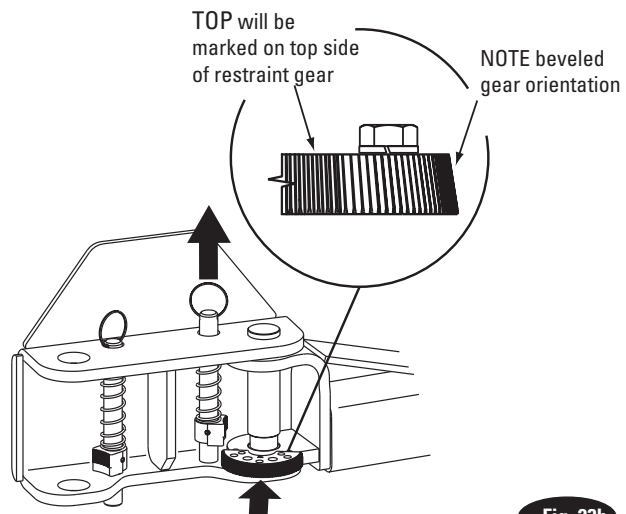
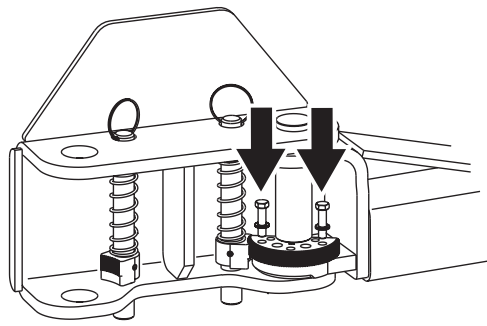
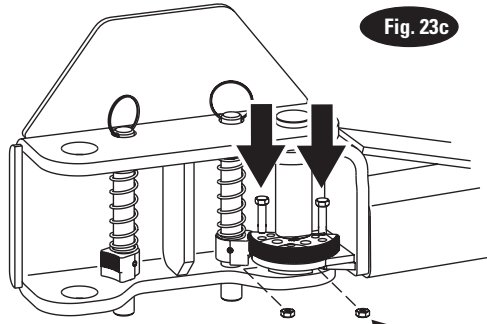

Fig. 23b



**BEARING BAR WITH 5 HOLES**

Fig. 23c



**BEARING BAR WITH 3 HOLES**

**BEARING BAR WITH 5 HOLES**

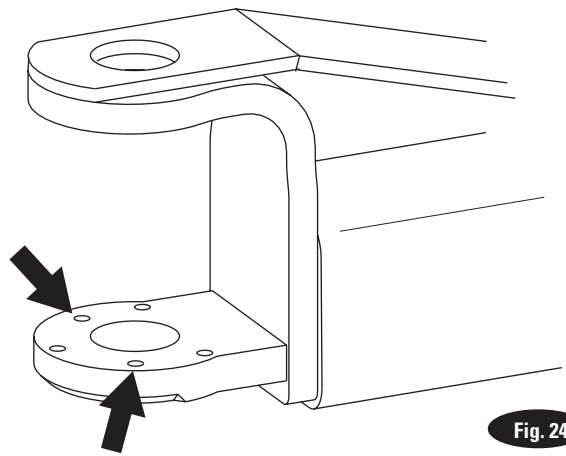
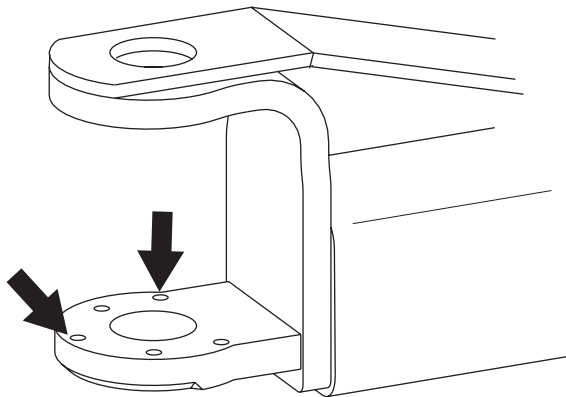

Fig. 24a

DO NOT use holes marked with arrows.

**BEARING BAR WITH 5 HOLES**



Use holes marked with arrow for Right Front and Left Rear.

**BEARING BAR WITH 3 HOLES**

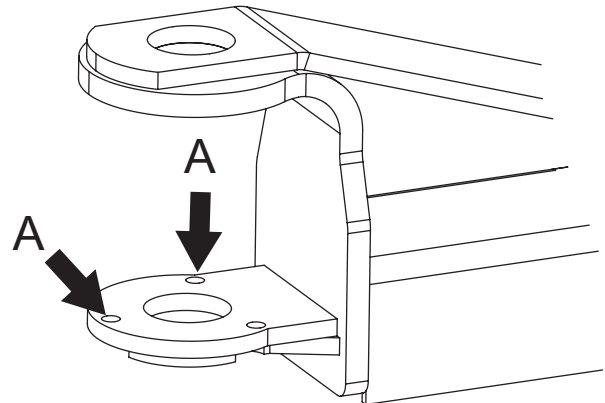

Use holes marked "A" for Right Front and Left Rear.

Fig. 24b

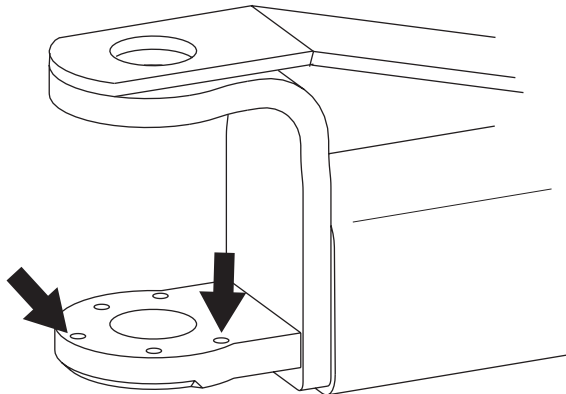

Use holes marked with arrow for Left Front and Right Rear.

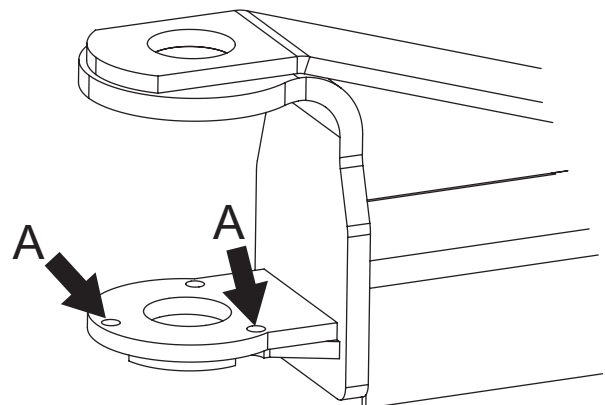

Use holes marked "A" for Left Front and Right Rear.

**NOTE:** To check operation of arm restraints, raise carriage 1" min. from full down position. Pull up on pin-ring and adjust arms to desired position. To engage restraint, let pin-ring down allowing gear teeth to mesh together. It may be necessary to rotate arm slightly to engage gear teeth.

**NOTE:** Pin & Ring, Spring, & Gear Block are all pre-assembled.

**17. Door Bumper Installation:**

- A) Press long bumper on column edge, Fig. 25.
- B) Press short bumper on top edge of carriage tube, Fig. 25.

**18. Latch Cable Adjustment:**

- A) Check to make sure the latch will properly engage and disengage. **Slowly** release the latch handle. A 1/8" gap between the top of the latch dog and the column is allowable.
- B) When raising, listen to latches to be sure that both latch dogs fall into latch slots. If they do not, loosen clamp and adjust tension as necessary.
- C) Install left latch cover using 5/16-18NC x 3/8" lg PHMS.

**19. Pressure Test:** Run lift to full rise and keep motor running for 5 seconds. Stop and check all hose connections. Tighten or reseal if required. Repeat air bleeding of cylinders.

**20. Equalizer Cable Adjustment:** Raise lift to check equalizer cable tension. Below carriage, grasp adjacent cables between thumb and forefinger, with about 15 lbs. effort you should just pull the cables together. Adjust at upper tie-offs Fig. 15.

**21. Latch Release Decal:** Install latch release decal on cover above latch release handle, Fig. 26.

**22. Pinch Point Decal Location:** Install enclosed pinch point decals. Place (1) decal on each column, Fig. 27. Decals should be a minimum of 8" from the bottom of decal to the ground.

**23. Wheel Spotting Dish:** Position wheel spotting dish as illustrated in Fig. 1a or 1b. Drill (2) 3/8" holes 2-1/2" deep in concrete floor using holes in wheel spotting dish as guide. Drive both anchors, provided, into concrete to secure dish.



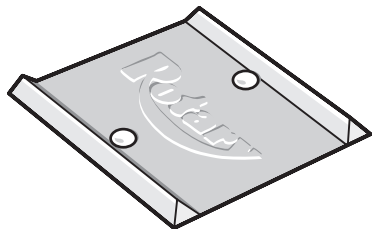
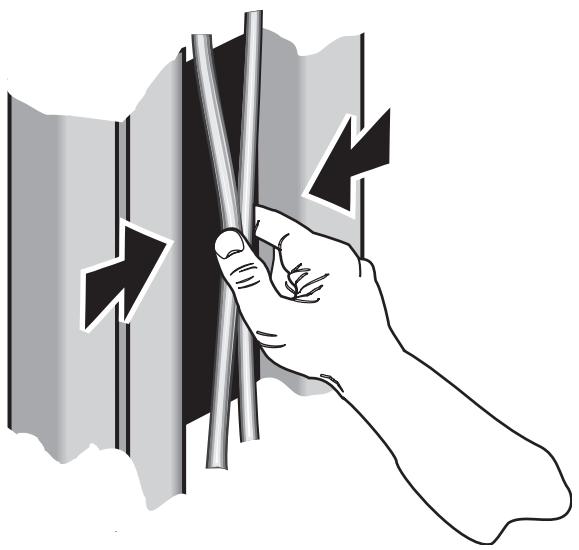
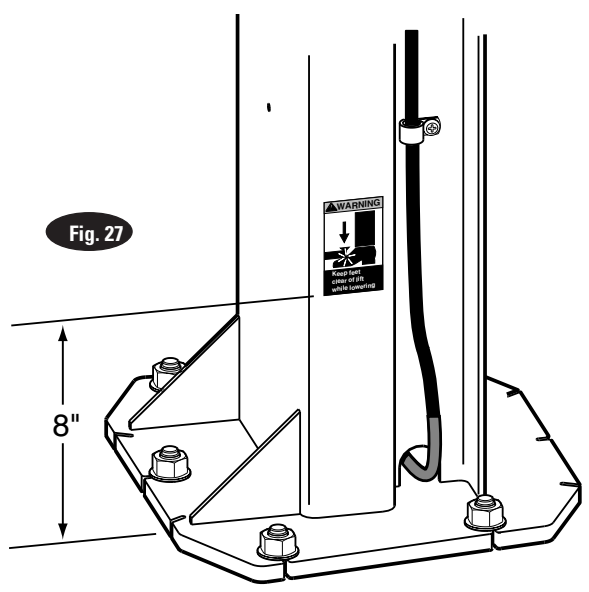
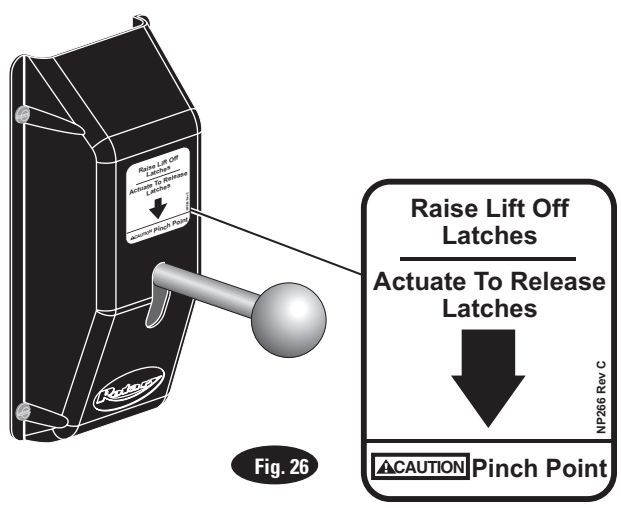
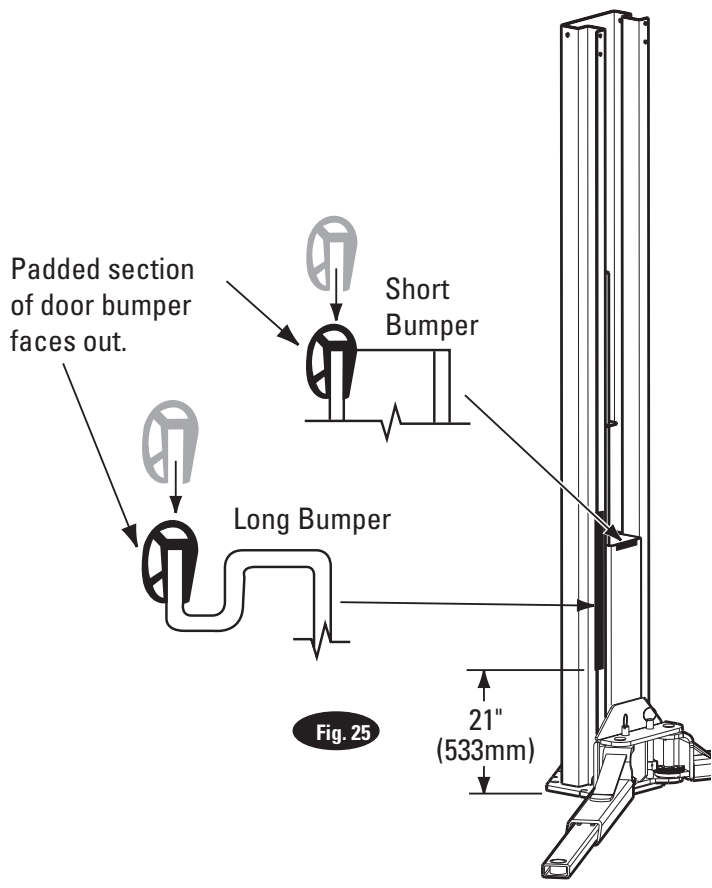

**Installer:** Please return this booklet to literature package, and give to lift owner/operator.

***Thank You***

***Trained Operators and Regular Maintenance Ensures Satisfactory Performance of Your Rotary Lift.***

***Contact Your Nearest Authorized Rotary Parts Distributor for Genuine Rotary Replacement Parts. See Literature Package for Parts Breakdown.***

**Rotary World Headquarters**  
2700 Lanier Drive  
Madison, IN 47250, USA  
www.rotarylif.com

**North America Contact Information**

Tech. Support:  
p 800.445.5438  
f 800.578.5438  
e userlink@rotarylif.com  
Sales: p 800.640.5438  
f 800.578.5438  
e userlink@rotarylif.com

**World Wide Contact Information**

World Headquarters/USA: 1.812.273.1622  
Canada: 1.905.812.9920  
European Headquarters/Germany: +49.771.9233.0  
United Kingdom: +44.178.747.7711  
Australasia: +60.3.7660.0285  
Latin America / Caribbean: +54.3488.431.608  
Middle East / Northern Africa: +49.771.9233.0

**© Vehicle Service Group<sup>SM</sup>**

Printed in U.S.A., All Rights Reserved. Unless otherwise indicated, ROTARY, and all other trademarks are property of Dover Corporation and its affiliates.

