

2023



FLEET CATALOG

YOUR ONE SOURCE FOR QUALITY BRAND NAME EQUIPMENT,
TOOLS AND SUPPLIES FOR THE FLEET INDUSTRY.

ASCOTTM
Supply Corporation

BEADBAZOOKA®



BB3L2, BB6L2, BB10L2



G471147HD



Bead Bazooka
Repair Kit BBVRK

G12941R



G12942R



G420303



G471105HD

COVERED BY ONE OR MORE U.S. PATENTS, INCLUDING: PAT. 10,800,216 PAT. 10,800,215 PAT. 10,759,238 PAT. 10,266,019 PAT. 8,752,604 PAT. 9,033,306 PAT. 9,822,893 PAT. 9,649,897 U.S. PAT. 10,214,399 For more information visit: www.gaithertool.com



Count on Murphy's to Keep Your Fleet Business Rolling

Tire Mounting Lubricants

Used by all major tire companies worldwide, Murphy's lubricants make truck and OTR tire mounting easier.

- premium materials
- consistent quality
- easy application

Concentrated & Ready to Use Leak Detectors

High performance leak detectors from a world leader in tire mounting products.

Black Tire Paint

Your go-to for a great retread finish. Quick drying.

- superior hiding versus competitive brands
- designed for use in tire painting machines or brush application
- ready-to use; water based for easy cleanup
- matte finish



TABLE OF CONTENTS

● AIR SYSTEMS

Air Compressors _____	6
Nitrogen Inflation Systems _____	14
Filters, Regulators & Lubricators _____	15
Air Hoses & Hose Products _____	16
Air Line Couplers & Plugs _____	18
Hose Fittings & Clamps _____	20

● AIR TOOLS

RPG Air Tools _____	21
Air Tools & Accessories _____	24

● WHEEL SERVICE PRODUCTS

Impact Sockets _____	34
Torque Wrenches & Torque Accessories _____	38
Loose Nut Prevention _____	43
Wheel Centering Products _____	46
Lug Nut Removal Products _____	48
Wheel Attaching Hardware _____	50
Tire & Wheel Service Tools _____	55
Stud & Hub Cleaning Tools _____	58

● LIFTING EQUIPMENT

Bottle Jacks _____	62
Jack Plates _____	69
Service Jacks _____	70
Jack Stands _____	81
Transmission & Specialty Jacks _____	86
Wheel Dollies _____	96
Hydraulic Shop Presses & Equipment _____	100
Brake Drum Handlers _____	102

● TIRE & WHEEL SERVICE

Tire & Wheel Accessories _____	104
Tire & Tube Sealants _____	105
Markers _____	112
Tire Branders & Accessories _____	113
Bead Breakers _____	115
Bead Seaters _____	120
Chloride Pumps _____	128
Mount & Demount Tools _____	130
Locking Ring Tools _____	135
Heavy Duty Hammers _____	136

General Purpose Hammers & Wedges _____ **137**
 Wrenches & Lug Wrenches _____ **138**
 Shop Service Tools _____ **141**
 Automatic Tire Inflation Systems _____ **142**
 Misc Tire Servicing Tools _____ **145**
 Safety Cages _____ **147**

● VALVE HARDWARE

TPMS Tools _____ **151**
 Tubeless Tire Valves (Truck) _____ **152**
 Truck & Specialty Valves _____ **153**
 Valve Caps, Cores & Extensions _____ **158**
 Special Application Products _____ **160**
 Valve Hardware Tools _____ **161**
 Tire Gauges _____ **163**
 Checking Stations _____ **166**
 Air Chucks _____ **167**
 Inflator Gauges _____ **171**

● SERVICE EQUIPMENT

Tire Changers & Accessories _____ **175**
 Wheel Balancers & Accessories _____ **178**
 Challenger Lifts _____ **179**

● WHEEL BALANCING SUPPLIES

Truck Wheel Weights _____ **180**
 Adhesive Wheel Weights _____ **183**
 Wheel Weight Displays & Kits _____ **188**
 Wheel Weight Tools _____ **189**
 Counteract Balancing Beads _____ **192**
 MAGNUM+ Tire Balancing _____ **193**
 EQUAL FLEXX Tire Balancing _____ **194**

● ALIGNMENT

Camber/Caster Tools _____ **196**
 Heavy Duty Alignment _____ **197**

● AUTOMOTIVE/FLEET SERVICE EQUIPMENT

Batteries, Chargers & Testers _____ **202**
 Bench Grinders & Shop Vises _____ **203**
 Pliers & Screwdrivers _____ **204**

Shop Cleaners & Brushes _____ **205**
 Shop Lights & Service Stickers _____ **207**
 Interior Protection Products _____ **208**
 Tire Displays, Racks & Carts _____ **210**
 Drains & Pumps _____ **211**
 Oil Accessories _____ **215**
 Safety Products _____ **216**
 Wheel Chocks _____ **218**
 Induction Heaters _____ **219**
 Mechanic's Gloves _____ **221**
 Heavy Duty Diagnostics _____ **223**
 Truck Shop Equipment _____ **225**

● FLUID EXCHANGE

Recovery & Recycling Systems _____ **228**
 Fluid Exchangers & Flushers _____ **229**
 Fluid Exchange Accessories _____ **230**

● TIRE REPAIR MATERIALS

Cabinets _____ **240**
 Cements, Sealants & Patches _____ **231**
 Air Buffers & Drills _____ **241**
 Tire Repair Tools & Accessories _____ **243**
 Tire Spreaders & Repair Stations _____ **253**

● ALPHABETICAL INDEX _____ 257

● NUMERIC INDEX _____ 260

Ascot Supply Corporation is not responsible for inadvertent typographical errors or omissions. Images included in this publication may appear different to the actual inventoried item.

magnum+

The Perfect Balance
Between Profits and Efficiency



THE ORIGINAL AND THE BEST

Put
Safety
Into Motion



Checkpoint®



by MARTINS

TIRE TOOLS AND SO MUCH
MORE **SINCE 1984...**



ESCO

The Proper Tools to Keep Your Equipment Moving...

CHAMPION[®]

AIR COMPRESSORS

Advantage Series

The Advantage Series is a fully packaged unit with all of the additional accessories customers need included. Advantage series compressors are typically shipped from the factory in 24 hours or less. Compressors are shipped ready to install and operate. Each new assembled unit comes with a standard three-year standard warranty, with option for a six-year extended warranty with the purchase of an extended warranty kit.

RECIPROCATING AIR COMPRESSOR

- 5-25 HP • **MAXIMUM PRESSURE:** Up to 175 PSIG • 17.0 to 203.6 ACFM at 175 PSIG • Two Stage, Splash Lubricated
- Tank-Mounted, Simplex and Duplex Models
- Vertical or Horizontal Configurations
- Package comes standard with up to six pre-installed options • Factory filled with ChampLub lubricant • Control panel with control voltage transformer



101-41112



101-40781

HEAVY DUTY

SIMPLEX & DUPLEX MODELS

SHIPPED QUICKLY

Ascot No.	Mfg. No.	HP or HPD	Part No.	Pump MFG No	Volts	Tank Capacity (Gal.)*	175 PSI Rating CFM Del'y	RPM	Dimensions (LxWxH)	Approx Ship Weight (Lbs.)
101-00058	VR5-8	5	ADVA-S01	R-15B	230/1	80V	17.0	737	35 x 27 x 75	590
101-00078	VR5-8	5	ADVA-S05	R-15B	208/3	80V	17.0	737	35 x 27 x 75	590
101-00158	VR5-8	5	ADVA-S126	R-15B	230/1	80V	17.0	737	35 x 27 x 75	590
101-01012	VR5-8	5	ADVA-S03	R-15B	230/3	80V	17.0	737	35 x 27 x 75	590
101-11012	VR5-8	5	ADVA-S148	R-15B	230/3	80V	17.0	737	35 x 27 x 75	590
101-40780	VR7F-8	7.5	ADVA-S168	R-15B	208/1	80V	22.3	949	35 x 27 x 75	630
101-40781	VR7F-8	7.5	ADVA-S13	R-15B	230/1	80V	22.3	949	35 x 27 x 75	630
101-40782	VR7F-8	7.5	ADVA-S17	R-15B	208/3	80V	22.3	949	35 x 27 x 75	630
101-40783	VR7F-8	7.5	ADVA-S15	R-15B	230/3	80V	22.3	949	35 x 27 x 75	630
101-41012	VR10-12	10	ADVA-S21	R-30D	208/3	120V	33.8	718	43 x 30 x 81	895
101-41112	VR10-12	10	ADVA-S19	R-30D	230/3	120V	33.8	718	43 x 30 x 81	895
101-42112	HR10-12	10	ADVA-S25	R-30D	208/3	120H	33.8	718	71 x 32 x 55	895
101-44112	HR10-12	10	ADVA-S23	R-30D	230/3	120H	33.8	718	71 x 32 x 55	895
101-41512	HR15-12	15	ADVA-S33	R-40A	208/3	120H	54.1	776	73 x 36 x 62	1210
101-42512	HR15-12	15	ADVA-S31	R-40A	230/3	120H	54.1	776	73 x 36 x 62	1210
101-43512	HR25-12	25	ADVA-S37	R-70A	208/3	120H	90.7	776	74 x 36 x 65	1557
101-44512	HR25-12	25	ADVA-S35	R-70A	230/3	120H	90.7	776	74 x 36 x 65	1557

* V: Vertical, H: Horizontal Configuration

SIZING A COMPRESSOR

APPLICATION GUIDE

CHAMPION®

DUPLEX AIR COMPRESSORS FULLY PACKAGED COMPRESSORS:

Compressors equipped with all of the desired options such as Mounted Magnetic Starter, Low Oil Level Monitor, Automatic Tank Drain, Air-Cooled Aftercooler and Vibration Isolators.

DUPLEX FULLY PACKAGED COMPRESSORS:

Two (2) Compressors and accessories supplied in one package provides the flexibility of single operations, alternating between compressors, or duplex operations to meet high air demands • **INCLUDES:** Automatic Tank Drain, Vibration Isolators, Two (2) Mounted Magnetic Starters plus alternator, Low Oil Level Monitors and Air Cooled Aftercoolers.



101-10325

Ascot No.	Mfg. No.	HP	Voltage/Phase	Tank Size	Tank Config.	Pump Mfg. No.	ACFM @175 PSIG	ACAC
101-51120	HR5D-12	5	230/1	120	Horiz.	R-15B	34.6	STD
101-53120	HR5D-12	5	208/3	120	Horiz.	R-15B	34.6	STD
101-54120	HR5D-12	5	230/3	120	Horiz.	R-15B	34.6	STD
101-75120	HR7D-12	7.5	230/1	120	Horiz.	R-30D	51.6	STD
101-75320	HR7D-12	7.5	208/3	120	Horiz.	R-30D	51.6	STD
101-75420	HR7D-12	7.5	230/3	120	Horiz.	R-30D	51.6	STD
101-10325	HR10D-25	10	230/3	250	Horiz	R-30D	69.6	STD

CHAMPION GASOLINE AIR COMPRESSORS

- Truck Bed Mountable, ideal for Field Service Applications
- Heavy Duty Two-Stage Compressors • V-Belt Drive with Totally Enclosed Belt Guard • Centrifugal unloader for loadless start prolongs motor life • Gasketless Design • *Vibration Isolators Included on 30 gallon models* • Each new assembled unit comes with a three-year standard warranty, six-year extended warranty

Ascot No.	Mfg. No.	Description
KITS		
106-37831	CC1137831	KOHLER KIT: Maintenance Kit for 14HP Kohler Engine Gasoline Air Compressor. Includes: Pre-filter, air filter, spark plug, fuel filter, engine oil, Champion air filter and compressor oil
106-37832	CC1137832	HONDA KIT: Maintenance Kit for 13HP Honda Engine Gasoline Air Compressor. Includes: Air filter, spark plug, engine oil, Champion air filter and compressor oil

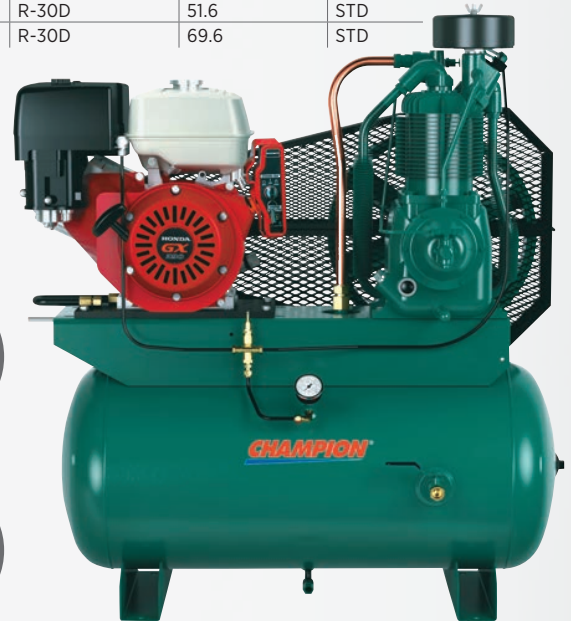

102-11530

Ascot No.	Mfg. No.	HP or HPD	Tank Size	Tank Config.	Engine Type	ACFM@175PSIG	RPM	Approx. Ship Weight (lbs.)
102-11530	HGR7-3H	13	30	Horiz.	Honda	23.2	1025	434
102-11560	HGR7-6H	13	60	Horiz.	Honda	23.2	1025	500
102-11880	HGR7-8H	13	80	Horiz.	Honda	23.2	1025	539
102-13730	HGR7-3K	14	30	Horiz.	Kohler	23.2	1025	434
102-13760	HGR7-6K	14	60	Horiz.	Kohler	23.2	1025	500
102-13780	HGR7-8K	14	80	Horiz.	Kohler	23.2	1025	539
101-10325	HR10D-25	10	230/3	250	Horiz	R-30D	69.6	STD



AIR COMPRESSORS

CHAMPION GASOLINE AIR COMPRESSORS

- Truck Bed Mountable, ideal for Field Service Applications
- Heavy Duty Two-Stage Compressors
- V-Belt Drive with Totally Enclosed Belt Guard
- Centrifugal unloader for loadless start prolongs motor life
- Gasketless Design
- *Vibration Isolators Included on 30 gallon models*
- Each new assembled unit comes with a three-year standard warranty, six-year extended warranty

GASKETLESS DESIGN

HEAVY DUTY



102-11530

KITS		
Ascot No.	Mfg. No.	Description
106-37831	CC1137831	KOHLER KIT: Maintenance Kit for 14HP Kohler Engine Gasoline Air Compressor. Includes: Pre-filter, air filter, spark plug, fuel filter, engine oil, Champion air filter and compressor oil
106-37832	CC1137832	HONDA KIT: Maintenance Kit for 13HP Honda Engine Gasoline Air Compressor. Includes: Air filter, spark plug, engine oil, Champion air filter and compressor oil

Ascot No.	Mfg. No.	HP or HPD	Tank Size	Tank Config.	Engine Type	ACFM@175PSIG	RPM	Approx. Ship Weight (lbs.)
102-11530	HGR7-3H	13	30	Horiz.	Honda	23.2	1025	434
102-11560	HGR7-6H	13	60	Horiz.	Honda	23.2	1025	500
102-11880	HGR7-8H	13	80	Horiz.	Honda	23.2	1025	539
102-13730	HGR7-3K	14	30	Horiz.	Kohler	23.2	1025	434
102-13760	HGR7-6K	14	60	Horiz.	Kohler	23.2	1025	500
102-13780	HGR7-8K	14	80	Horiz.	Kohler	23.2	1025	539
101-10325	HRT10D-25	10	230/3	250	Horiz	R-30D	69.6	STD

Centurion

CENTURION II | 13 HP RECIPROCATING COMPRESSOR/GENERATOR

- Two-stage splash lubricated RV15A compressor pump
- Honda GX390 engine with electric start
- Industrial 4000-watt generator with (2) 120V, 15 amp and (1) 240V, 20 amp receptacles
- Twin 4-gallon horizontal air receiver tanks
- Manual receiver drain valve
- Lifting hook
- Belt drive with totally enclosed belt guard
- Gas pilot valve
- Comprehensive base plate
- INCLUDES: (2) Pressure gauges - the left gauge indicates tank pressure and the right gauge indicates output pressure; adjustable pressure regulator; pressure relief valve, air socket



101-73904

Ascot No.	Mfg. No.	PART. No.	ENGINE MODEL	HP	TANK CAP. (GAL)	Pump MFG No.	Continuous Generator with Comp Off-Load	Max. AC Output	175 PSI Rating*			Dimensions (LxWxH)	Approx. Ship Weight (Lbs.)
									RPM	CFM Displ.	Rating CFM Del'y		
101-73904	HGRV7-LPH-G	CC1153480	HONDA GX390	13	(2) 4	RV-15A	3500 watts	4000 watts	784	22.9	17.9	46" x 22" x 35"	490

L-SERIES

Rotary Screw Air Compressors

CHAMPION[®]

The Champion L-Series Rotary Screw Compressors are highly competitive, expertly-designed packages that use the latest design techniques to give you industry-leading reliability, performance, and value. When used in 100% duty cycle applications, Rotary Screw compressors from Champion are a great, quiet alternative to a reciprocating compressor.

STANDARD FEATURES:

- Advanced but simple package design lowering maintenance and service costs and lengthening service life
- Belt-driven
- Integrated Airends ensure superior serviceability
- Available in fixed and variable speed
- State-of-the-art dual position pilot controller
- High-quality, sound-insulating enclosure panels
- Low-noise, thermostatically-controlled, motor-driven fan
- Tank or basemount with optional dryer configurations (AirStation)
- Zero air-loss auto tank drain on Air Station
- **L-SERIES WARRANTY:** Standard one-year warranty on package, premium ten-year warranty available

101-71023



105-00750

ADVANCED
DESIGN

BELT
DRIVEN

AIR COMPRESSORS

CHAMPION L-SERIES ROTARY SCREW AIR COMPRESSORS



Ascot No.	Mfg. No.	Drive Motor		Voltages Available	Nominal PresSure		Noise level	Base Mount	
		HP	KW		PSIG	ACFM		DB(A)	Dimensions (LxWxH)
101-45231	L04	5	4	230 1 phase	100	19.4	68	26" x 24" x 37"	373
				208-230/460/575 3 PH	125	18.4			
				—	190	14.0			
101-57523	L05	7.5	5	230 1 phase	100	22.2	68	26" x 24" x 37"	373
				208-230/460/575 3 PH	125	20.7			
				—	190	16.4			
101-71023	L07	10	7	208-230/460/575 3 PH	100	45.9	71	27" x 25" x 41"	452
					125	37.4			
					190	30.0			
101-11153	L11	15	11	208-230/460/575 3 PH	100	66.0	73	27" x 25" x 41"	483
					125	56.8			
					190	46.6			
101-15203	L15	20	15	208-230/460/575 3 PH	100	95.31	74	31" x 28" x 47"	739
					125	79.8			
					190	63.5			
101-18253	L18	25	18	208-230/460/575 3 PH	100	114.7	74	31" x 28" x 47"	796
					125	96.7			
					190	82.6			
101-22303	L22	30	22	208-230/460/575 3 PH	100	128.8	68	53" x 35" x 64"	810
					125	113.3			
					190	92.1			
101-23303	L23	30	22	208-230/460/575 3 PH	100	146.8	68	53" x 35" x 64"	1433
					125	121.8			
					190	105.2			
101-26353	L26	35	26	208-230/460/575 3 PH	100	170.9	69	53" x 35" x 64"	1493
					125	145.8			
					190	121.4			
101-29403	L29	40	29	208-230/460/575 3 PH	100	194.9	71	53" x 35" x 64"	1501
					125	169.8			
					190	145.4			

AIR STATION SPECIFICATIONS, 60 HZ

Ascot No.	Mfg. No.	Dryer Model	Receiver Size (Gallons)	Refrigerant	Weight (LBS.)			Dimensions (LxWxH)		
					80 GAL.	120 GAL.	240 GAL.	80 GAL.	120 GAL.	240 G AL.
105-00425	L04	CRN25	80, 120, 240	R134A	LESS DRYER 791 WITH DRYER 877	LESS DRYER 874 WITH DRYER 960	LESS DRYER 1226 WITH DRYER 1312	LESS DRYER 52 x 32 x 68 WITH DRYER 63 x 32 x 68	LESS DRYER 73 x 32 x 68 WITH DRYER 72 x 32 x 68	LESS DRYER 90 x 37 x 74 WITH DRYER 88 x 37 x 73.8
105-00535	L05	CRN35	80, 120, 240		LESS DRYER 882	LESS DRYER 905	/	LESS DRYER 52 x 32 x 68 WITH DRYER 63 x 32 x 68	LESS DRYER 73 x 32 x 68 WITH DRYER 72 x 32 x 68	/
105-00750	L07	CRN50	80, 120		LESS DRYER 853 (387)	LESS DRYER 936 (425)		LESS DRYER 52 x 32 x 68 WITH DRYER 63 x 32 x 68	LESS DRYER 73 x 32 x 68 WITH DRYER 72 x 32 x 68	
105-01175	L11	CRN75			120 GAL. ONLY	LESS DRYER 1194 (542)	WITH RNC DRYER 1505	LESS DRYER 73 x 32 x 74	WITH DRYER 80 x 32 x 74	
105-01590	L15	CRN100 CES90	120		LESS DRYER 1251 (567)	WITH RNC DRYER 1584 (719)				
105-18125	L18	CRN125 CES120			LESS DRYER 1265	WITH RNC DRYER 1604				
105-22150	L22	CRN150 CES140								

LV/LVR-Series

Rotary Vane Air Compressors

CHAMPION®

The LV Series range of compressors is engineered to meet the most stringent of specifications. Their compact, simple, robust and integrated design allows them to fit anywhere undercover. They are easy to install and maintain as well as extremely quiet. The LV Series is available in either tripod or tank mounted versions. They are designed for a wide variety of applications including automobile, car body shops, wood working, dentistry, laundry, packaging and machine tools.

LV-SERIES SPECIFICATIONS:

- 2-10 hp • Less than 3 ppm oil carryover • Available as a Simplex or Duplex tank mounted unit • Standard starter • **SLOW SPEED:** 1760 RPM • 100% duty cycle
- Continuous run or start/stop • TEFC motor
- Direct drive • **Standard 2 Year Warranty**

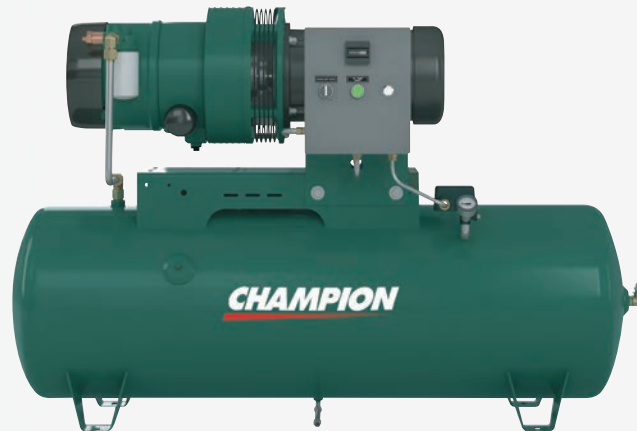

LV-Series: Duplex



LV-Series: Simplex

LV SERIES: SIMPLEX

Ascot No.	Mfg. No.	HP	KW	Voltage/Phase	Mount. Config.	Tank Style	Tank Cap. (Gal.)	CFM 100 PSIG	CFM 150 PSIG	Noise Level (dBA)	Air Outlet NPT	Oil Cap. (Gal.)	Wt. (Lbs.)	Dimensions (LxWxH)	Starter	After cooler
104-01201	LV01PUTS	2	1	115/208-230 1 Ph 208-230/460 3 Ph	Tripod	N/A	N/A	6.3	4.5	65	3/8"	0.5	130	30" x 11" x 18"	Yes	Yes
104-01202	LV01PURHS-3	2	1	115/208-230 1 Ph 208-230/460 3 Ph	Tank	Horiz.	30	6.3	4.5	65	3/8"	0.5	240	41" x 19" x 34"	Yes	Yes
104-04501	LV04PUTAS	5	4	208-230 1 Ph 208-230/460 3 Ph	Tripod	N/A	N/A	19.5	16	72	1/2"	0.5	315	42" x 24" x 24"	Yes	Yes
104-04502	LV04PURVS-8	5	4	208-230 1 Ph 208-230/460 3 Ph	Tank	Vert.	80	19.5	16	72	1/2"	0.5	570	36" x 26" x 66"	Yes	Yes
104-04503	LV04PURHS-8	5	4	208-230 1 Ph 208-230/460 3 Ph	Tank	Horiz.	80	-	16	72	1/2"	0.5	425	65" x 22" x 40"	Yes	Yes
104-05750	LVR08PURVS-8	7.5	5.5	208-230 1 Ph 208-230/460 3 Ph	Tank	Vert.	80	-	22	72	1/2"	1.15	695	39" x 26" x 69"	Yes	Yes
104-05751	LVR05PURHS-8	7.5	5.5	208-230 1 Ph 208-230/460 3 Ph	Tank	Horiz.	80	-	22	72	1/2"	1.15	550	66" x 22" x 43"	Yes	Yes
104-07101	LVR07PURHS-8	10	7.5	208-230/460 3 Ph	Tank	Horiz.	80	-	28.9	72	3/4"	1.15	670	66" x 22" x 43"	Yes	Yes

LV SERIES: DUPLEX

Ascot No.	Mfg. No.	HP	KW	Voltage/Phase	Mount. Config.	Tank Style	Tank Cap. (Gal.)	CFM 100 PSIG	CFM 150 PSIG	Noise Level (dBA)	Air Outlet NPT	Oil Cap. (Gal.)	Wt. (Lbs.)	Dimensions (LxWxH)	Starter	After cooler
104-04120	LV04PDRHS-12	5	4	208-230 1 Ph 208-230/460 3 Ph	Tank	Horiz.	120	39	32	75	1/2"	1	845	72" x 27" x 48"	Yes	Yes
104-05127	LVR05PDRHS-12	7.5	5.5	208-230 1 Ph 208-230/460 3 Ph	Tank	Horiz.	120	-	44	76	1/2"	1	1210	76" x 27" x 50"	Yes	Yes
104-07121	LVR07PDRHS-12	10	7.5	208-230 1 Ph 208-230/460 3 Ph	Tank	Horiz.	120	-	57.8	77	3/4"	1	1325	76" x 27" x 50"	Yes	Yes

AIR COMPRESSORS

Refrigerated Air Dryers

REFRIGERATED AIR DRYERS - SPECIAL FEATURES:

- Effective moisture removal at all flow rates
- Combination separator/filter
- Ideal for air compressors equipped with an air cooled aftercooler

SIZING A 3-IN-1 HIGH INLET DRYER

Follow the steps below to size your dryer:

1. Use the table below that identifies your inlet temperature to your dryer.
2. In the chart select the inlet pressure that will be entering your dryer.
3. Determine SCFM to compensate for air line leaks and pressure drops.
4. Select the SCFM requirement for your dryer based on the SCFM coming out of the air compressor.

RULE OF THUMB CALCULATION

ROTARY SCREW AIR COMPRESSOR
SCFM = Compressor HP x 4.5

RECIPROCATING AIR COMPRESSOR
SCFM = Compressor HP x 3.5

5. Once the correct HP rating has been selected based on the air volume requirements, you will need to know the type of available electric service to determine the need for a single phase or three phase compressor.

1. Identify the table that shows 120°F (in this example it would be table 3)
2. From the same table (table 3) select the inlet pressure of dryer. In this example (140 PSIG).
3. Use Rule of Thumb Calculation to determine SCFM. **20HP x 3.5 = 70 SCFM**
4. Locate 70 SCFM under 140 PSIG column. Follow across to dryer part number.
ANSWER: Customer needs part number 3530.



105-00015

Ascot No.	Mfg. No.	Flow	Voltage	In/Out Connect.	SIZE (LxWxH)	Approx. Ship Weight (LBS.)
105-00015	CRN15	15	115/1/60	3/8" OD	15x12.6x12.6	69 Lbs.
105-00025	CRN25	25	115/1/60	1/2" NPT	26x19x21	142 Lbs.
105-00035	CRN35A1	35	115 or 230/1/60	1/2" NPT	26x19x21	146 Lbs.
105-00050	CRN50A1	50	115 or 230/1/60	1/2" NPT	26x19x21	152 Lbs.
105-00075	CRN75A1	75	115 or 230/1/60	3/4" NPT	33x25x26	209 Lbs.
105-00100	CRN100A1	100	115 or 230/1/60	1" NPT	38x29x20	251 Lbs.
105-00125	CRN125A1	125	115 or 230/1/60	1" NPT	38x29x20	273 Lbs.
105-00150	CRN150A1	150	115 or 230/1/60	1" NPT	38x29x20	279 Lbs.

CHAMPION CRH SERIES HIGH INLET TEMPERATURE REFRIGERATED AIR DRYER

TABLE 1: 180° INLET

Mfg. No.	100 PSIG	150 PSIG	175 PSIG
CRH20	18	22	23
CRH25	23	27	29
CRH35	32	38	41
CRH50	45	54	58
CRH75	68	81	87
CRH100	91	108	116
CRH125	114	135	145

TABLE 2: 150° INLET

Mfg. No.	100 PSIG	150 PSIG	175 PSIG
CRH20	21	25	26
CRH25	26	31	33
CRH35	37	44	47
CRH50	52	62	67
CRH75	78	93	100
CRH100	105	124	133
CRH125	131	155	167

TABLE 3: 120° INLET

Mfg. No.	100 PSIG	150 PSIG	175 PSIG
CRH20	23	29	30
CRH25	30	35	38
CRH35	42	49	53
CRH50	59	70	75
CRH75	88	105	113
CRH100	118	140	151
CRH125	148	176	189



C-AIRE GAS ENGINE COMPRESSOR

- **Two-Stage** compressor that is just the right size for a service truck using a 1" or 3/4" impact wrench and is great for farm service use
- **INCLUDES:** Ball valve, Honda engine, electric start, engine idle down, oil drain tube, tank drain, large displacement 3 cylinder pumps, large oil sight glass, liquid filled gauge, full synthetic oil & mounting pads



102-13030

C-AIRE SIMPLEX COMPRESSORS

- **Oversized after coolers** remove over 60% of water vapor, humidity or moisture • Large displacement 3-cylinder pumps run slower thus increasing the longevity and contributes to them being quieter • **ALL UNITS INCLUDE:** Ball valve, tank drain, oil drain tube, full synthetic oil, large sight glass and liquid fill gauge • *Installation kit only included with Fully Packaged units (4 mounting pads, 4 anchor bolts, 12" steel braided flex hose)*



101-75080

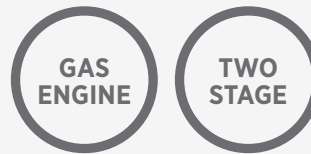

Ascot No.	Mfg. No.	HP	Stage	CFM @175 PSIG	Pump	Pump RPM	Main Bearings	Oil	Volts	AMPS	Motor RPM	Breaker Size	Tank Size (GAL.)	Dimensions (LxWxH)	Wt. (Lbs.)
101-50080	A050V080-1230	5	2	17	2 Cylinder Cast Iron	885	50,000 Hours	Full Synthetic	208/230, 1 Phase	21@208V, 19.1@230V	1745	40 Amp	80	35" x 24" x 70"	515
101-75080	A075V080-1230	7.5	2	24	3 Cylinder Cast Iron	649	50,000 Hours	Full Synthetic	208/230, 1 Phase	33.3@208V, 31.3@230V	1760	50 Amp	80	34" x 24" x 73"	625
102-13030	A130H030-G	13	2	26	3 Cylinder Cast Iron	745	50,000 Hours	Full Synthetic	800	N/A	N/A	N/A	30	42" x 17" x 45"	474

CHAMPION VOLTAGE CONVERSION KITS

- If 460V, 3 phase service is needed voltage conversion kits are available

Ascot No.	Mfg. No.	Description
106-11727	TEN011727	Voltage Conversion Kit, Simplex - 5HP and 7.5HP from 230V/3 Phase to 460V/3 Phase
106-11728	TEN011728	Voltage Conversion Kit, Simplex - 10HP from 230V/3 Phase to 460V/3 Phase
106-11729	TEN011729	Voltage Conversion Kit, Simplex - 15HP from 230V/3 Phase to 460V/3 Phase
106-11730	TEN011730	Voltage Conversion Kit, Simplex - 25HP from 230V/3 Phase to 460V/3 Phase



106-11727

CHAMPION MAINTENANCE PARTS

Ascot No.	Mfg. No.	Description
106-28530	M2853	Pilot Unleader Valve for Gas Compressors
106-89090	P08909A	Champion Oil, 1-Gallon
106-94730	P09479A	Champion Oil, 1-Quart
117-05050	P05050A	Filter Element for Gas and Small Electric Units
117-05051	P05051A	Filter Element for Large Electric Units
106-11882	Z11882	Compressor Service Kit for RV-15/R-15 Pump INCLUDES: Lubricant, Air Filters & Oil Filter
106-11883	Z11883	Compressor Service Kit for RV-30/R-30 Pump INCLUDES: Lubricant, Air Filters & Oil Filter
106-11884	Z11884	Compressor Service Kit for R-40 Pump INCLUDES: Lubricant, Air Filters & Oil Filter
106-13194	CC1031194	Engine Maintenance Kit for 13 HP Gas Compressors
106-00519	M519C	Replacement 1/4 NPT Gauge for Compressors





NITROGEN INFLATION SYSTEMS



BRANICK 130 NITROGEN INFLATION SYSTEM

The **MODEL 130** can be used with a nitrogen bottle or connected to a nitrogen generator to inflate up to 6 (4 hoses included) tires with high purity nitrogen. The integrated auto-inflator has a pressure range up to 145 psi and performs top-offs as well as automated nitrogen conversions, just set the pressure and the inflator does the rest. Branick equipment lasts and our Model 130 is no different, with all steel construction to take everyday use. The rechargeable battery has a visible charging indicator to let you know when you're ready to go. The mobility and features

of the Model 130 make nitrogen service simple, fast and economical.

- **Hands Free Auto-inflator**
- Convert up to 6 tires (*requires 2 optional hoses*)
- Rechargeable battery with indicator
- Convenient parts tray
- Durable all-steel construction



119-00130



119-00485



BRANICK 485 NITROGEN INFLATION SYSTEM

- **The 485 is totally automatic and completely mobile, enabling the operator to wheel the unit directly to any vehicle**
- Zero installation costs
- No electrical requirements to operate
- Industrial grade HD battery
- Efficient membrane
- Low maintenance cost
- Connect to any air-line and you're inflating tires. Plug and Play!

Ascot No.	Mfg. No.	Description
119-00485	485	Branick 485 Nitrogen Inflation System

BRANICK 500 NITROGEN TOWER INFLATION SYSTEM

Branick's tower systems are designed to be durable, easy to operate and efficient. On the inside are PRISM membranes with a 5 year warranty, whose 1.9:1 air input to nitrogen output ratio is the best in the industry. The top quality internal components include an auto shut-off to reduce compressor use. On the outside is an all steel shell for durability with easily accessible front mounted controls and simple to maintain filters, 5 years of free filters are included. Air input and nitrogen output pressure gauges give you performance at a glance. The inline nitrogen purity test port lets you verify that you're getting the purity you need for the job.

- **Best Air to Nitrogen Ratio on the Market at 1.9:1**
- PRISM Membranes, the industries' best
- Compressor saving auto shut-off
- Simple operation
- Adjustable nitrogen and purity test port
- Air input/nitrogen output pressure gauges
- Small footprint minimizes space



119-00500

Ascot No.	Mfg. No.	Description
119-00130	130	Branick 130 Nitrogen Inflation System

Ascot No.	Mfg. No.	Description
119-00500	500	Branick 500 Nitrogen Tower Inflation System



FILTERS, LUBRICATORS & REGULATORS



GENERAL PURPOSE FILTERS

• Removes harmful water condensate, pipe scale, dirt and rust from your compressed air system • Prevents corrosive damage to compressed air equipment and finished products • Protects components and air tools from premature failure • Installed upstream of regulators to prevent valve failure • Also used as pre-filters to oil removing and coalescing filters to ensure high efficiency and long element life in applications such as paint spraying, instrumentation and pharmaceuticals • Porous sintered bronze element

Ascot No.	Mfg. No.	Pipe Size	Max. Flow SCFM	Bowl Capacity	Bowl Type	Drain	OPERATING Temp.	Max. Pressure	Filter Element
111-30002	F300-02	1/4"	27	1 Oz.	Poly	Manual	40°-125°F	150 PSIG	20 micron
111-35200	F352	1/4"	48	5 Oz.	Poly	Manual	40°-125°F	150 PSIG	40 micron
111-35201	F352W	1/4"	48	6 Oz.	Metal	Manual	40°-160°F	250 PSIG	40 micron
111-35202	F352Z	1/4"	48	5 Oz.	Poly	Piston Auto	40°-125°F	150 PSIG	40 micron
111-35203	F352FW	1/4"	48	6 Oz.	Metal	Float Auto	40°-120°F	175 PSIG	40 micron
111-35300	F353	3/8"	75	5 Oz.	Poly	Manual	40°-125°F	150 PSIG	40 micron
111-35301	F353W	3/8"	75	5 Oz.	Metal	Manual	40°-160°F	250 PSIG	40 micron
111-35302	F353Z	3/8"	75	6 Oz.	Poly	Piston Auto	40°-125°F	150 PSIG	40 micron
111-35303	F353FW	3/8"	75	6 Oz.	Metal	Float Auto	40°-120°F	175 PSIG	40 micron
111-35400	F354	1/2"	100	5 Oz.	Poly	Manual	40°-125°F	150 PSIG	40 micron
111-35401	F354W	1/2"	100	6 Oz.	Metal	Manual	40°-160°F	250 PSIG	40 micron
111-35402	F354Z	1/2"	100	5 Oz.	Poly	Piston Auto	40°-125°F	150 PSIG	40 micron
111-35403	F354FW	1/2"	100	6 Oz.	Metal	Float Auto	40°-120°F	175 PSIG	40 micron
111-37600	F376W	3/4"	230	10 Oz.	Metal	Manual	40°-160°F	250 PSIG	40 micron
111-37601	F376FW	3/4"	230	10 Oz.	Metal	Float Auto	40°-120°F	175 PSIG	40 micron
111-32908	F329-08	1"	300	29 Oz.	Metal	Manual	40°-160°F	250 PSIG	40 micron



111-30002



111-35201

LUBRICATORS

• Injects a fine stream of oil into the air stream to automatically lubricate air operated tools and other devices • Extends life of downstream components • Precise control of oil feed with needle valve adjustment knob • Adds minimal pressure drop to the air system

• Features three position non-rising knob: push to lock, pull to adjust, detach to make tamper resistant

- High air flow
- Precise visual adjustment control
- Low flow to establish drip rate
- "W" is with sight glass and metal bowl

Ascot No.	Mfg. No.	Pipe Size	Max. Flow SCFM	Bowl Cap.	Bowl Type	Operating Temp.	Max. Pressure	Oil Delivery
113-01352	L352W	1/4"	16	5 Oz.	Metal	40°-175°F	200 PSIG	2 SCFM
113-01354	L354W	1/2"	142	5 Oz.	Metal	40°-175°F	200 PSIG	2 SCFM



113-00353



113-01353

REGULATORS

• Specialized control valve reduces upstream supply pressure level to a specified constant downstream pressure

- Regulates air pressure of the airline
- Self-relieving style units

• Available in T-handle or adjustment knob

- Adjustment knob features three position non-rising knob: push to lock, pull to adjust, detach to make tamper resistant
- Reinforced diaphragm for repeated accuracy

Ascot No.	Mfg. No.	Pipe Size	Max. Flow SCFM	Adjustment Type	Pressure Gauge Part No.	Gauge Part	Operating Temp.	Operating Pressure
112-00162	R162	1/4"	25	Adjustment Knob	117-01681*	1/8" NPT	40°-120°F	5 to 125 PSIG
112-00262	R262**	1/4"	25	Adjustment Knob	117-01681*	1/8" NPT	40°-120°F	5 to 125 PSIG
112-00352	R352	1/4"	50	Adjustment Knob	117-01481*	(2) 1/4" NPT	40°-120°F	5 to 125 PSIG
112-00353	R353	3/8"	80	Adjustment Knob	117-01481*	(2) 1/4" NPT	40°-120°F	5 to 125 PSIG
112-00354	R354T	1/2"	100	T-Handle	117-01481*	(2) 1/4" NPT	40°-120°F	5 to 125 PSIG
112-00376	R376T	3/4"	220	T-Handle	117-01481*	(2) 1/4" NPT	40°-120°F	5 to 125 PSIG
112-00378	R378T	1"	250	T-Handle	117-01481*	(2) 1/4" NPT	40°-120°F	5 to 125 PSIG
112-03910	R3910	1-1/4"	700	T-Handle	117-01481*	(2) 1/4" NPT	40°-120°F	5 to 125 PSIG
112-03912	R3912	1-1/2"	700	T-Handle	117-01481*	(2) 1/4" NPT	40°-120°F	5 to 125 PSIG
112-01352	R352T	1/4" Regulator - T-Handle						
112-01354	R354GH	1/2" High Pressure Regulator - 10 to 250 PSI						



112-00378



112-00352

AIR HOSES & ACCESSORIES



1/2" ULTRAFLEX AIR HOSE

- Specially designed hose that has been developed to cater to today's high demand conditions and use
- Stays flexible in the cold and does not kink in the heat
- Full airflow in all weather conditions
- 300 psi working pressure
- 3/8" male fittings
- Available in 32', 65' and 100' lengths



Ascot No.	Mfg. No.	Description
121-56323	56.3234RPG	1/2" x 32' UltraFlex Air Hose - 300 PSI
121-56324	56.3245RPG	1/2" x 65' UltraFlex Air Hose - 300 PSI

COUPLED AIR HOSES

- Reinforced with heavy duty polyester cord



Ascot No.	Mfg. No.	Description
121-01225	98101646	Coupled 1/2" x 25' Reinforced Domestic Air Hose
121-01250	98101648	Coupled 1/2" x 50' Reinforced Domestic Air Hose
121-03825	98101640	Coupled 3/8" x 25' Reinforced Domestic Air Hose
121-03851	98101642	Coupled 3/8" x 50' Reinforced Domestic Air Hose

RPG HIGH PERFORMANCE BLOW GUN KIT

- Produces more air flow than standard blow guns, fits any hose with 1/4" NPT thread, variable flow trigger provides precise control
- Maximum working pressure 120PSI
- Kit includes high performance blow gun, ultimate flow tip, rubber tip, quiet flow nozzle, 6" extension, 3" needle and reducer



Ascot No.	Mfg. No.	Description
128-00006	HPBGK-7	RPG 7-Piece High Performance Blow Gun Kit

1/2" X 50' AIR HOSE REEL

- Mounting base is slotted and roller arm has 5 positions for multiple mounting configurations.
- Heavy steel construction adds durability and longer life cycles
- Rubber air hose with heavy-duty crimping and spring guard ensure longevity
- Automatic return via heavy-duty sealed spring with 8 locking stops, roller guide and ball stop
- 300 PSI maximum pressure
- Ship weight 53 lbs



125-00760
Air Hose Reel

Ascot No.	Mfg. No.	Description
125-00760	760	3/8" X Air Hose Reel
126-00761	761	1/2" X Air Hose Reel

1/4" BULK DOMESTIC AIR HOSE

- Used in automotive, agricultural and construction applications • 1/4" ID x 325 PSI • Temp Range: -40°F to +200°F • Multi-spiral polyester yarn reinforcement makes hose easy to handle and very flexible
- EPDM tube and cover resists abrasion, heat and ozone
- MADE IN THE USA



121-14700



Ascot No.	Mfg. No.	Description
121-14700	91008400	1/4" x 700' Domestic Bulk Air Hose (325 PSI) Reel

AIR HOSES & ACCESSORIES



HEAVY DUTY INDUSTRIAL REELS

- **Compact design**
- Substantial support
- Air/Water (OLP), Oil (OMP) or Grease (OHP)
- All-steel construction with engineered ribs/forms
- Baked-on powder coat finish provides corrosion resistance
- **MADE IN THE USA**



COMPACT DESIGN

CORROSION RESISTANT FINISH

ALL-STEEL BUILD

126-07850

Ascot No.	Mfg. No.	Hose ID	Hose OD	Hose Length	Hose PSI	Temp.
125-07650	7650 OLP	3/8"	.688	50'	300	150° F
125-07670	7670 OLP	3/8"	.688	70'	300	150° F
126-07850	7850 OLP	1/2"	.844	50'	300	150° F
125-07651	7650 OMP	3/8"	.690	50'	2250	210° F
126-07851	7850 OMP	1/2"	.815	50'	2000	210° F
124-07450	7450 OHP	1/4"	.590	50'	5000	210° F
125-07652	7650 OHP	3/8"	.750	50'	4000	210° F

AIR LINE COUPLERS & PLUGS



TYPE A

1/4" LINCOLN LONG NOSE

- Brass plated couplers with hardened steel balls and stainless steel springs
- Plugs heat-treated to reduce wear on critical mating surfaces
- Interchange with Lincoln "Long Nose Series" as well as units produced by other manufacturers



131-61486



131-61550



131-61548

Ascot No.	DILL. NO.	MILTON NO.	AMFLO. NO.	SCHRADER No.	THREAD	NPT
COUPLERS						
131-61486	N/A	794	C27	598392	Male	1/4"
131-61548	123	790	C28	506329	Female	1/4"
ADAPTER PLUGS						
131-61550	126	791	CP27	700665	Male	1/4"
131-61551	125	792	CP28	700664	Female	1/4"

TYPE B

1/4" ARO SERIES

- Brass plated couplers with hardened steel balls and stainless steel springs
- Plugs heat-treated to reduce wear on critical mating surfaces
- Interchange with Aro 210 series as well as units produced by other manufacturers
- Maximum working pressure 300 PSI

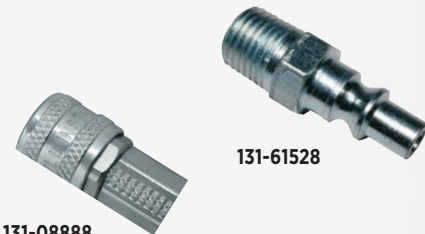

131-08888



131-61528

Ascot No.	DILL. NO.	MILTON NO.	SCHRADER No.	AMFLO. NO.	THREAD	NPT
COUPLERS						
131-61526	8888	775	506599	C38	Female	1/4"
131-61527	N/A	776	3525	C37	Male	1/4"
131-08888	Push-to-Connect	775	Dill 8888	Push-to-Connect	Female	1/4"
ADAPTER PLUGS						
131-61529	8889	778	700757	CP38	Female	1/4"
131-61528	8891	777	700776	CP37	Male	1/4"

AIR LINE COUPLERS & PLUGS



TYPE C

1/4" AUTOMOTIVE STANDARD (TRU-FLATE)

- Brass plated couplers with hardened steel balls and stainless steel springs • Plugs heat-treated to reduce wear on critical mating surfaces • Interchange with Tru-Flate 10 and 100 type series as well as units produced by other manufacturers
- Maximum working pressure 300 PSI

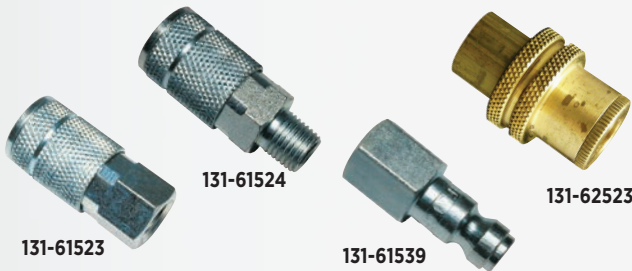

Ascot No.	DILL. NO.	MILTON NO.	AMFLO. NO.	SCHRADER No.	THREAD	NPT
COUPLERS						
131-61523	D-13	785	C2	506079	Female	1/4"
131-61524	D-12	786	C1	506009	Male	1/4"
131-62523	D-13R				Female	1/4"
ADAPTER PLUGS						
131-61539	D-3C	784	CP2	700691	Female	1/4"
131-61538	D-2C	783	CP1	700735	Male	1/4"

TYPE D

1/4" INDUSTRIAL INTERCHANGE SERIES

- Brass plated couplers with hardened steel balls and stainless steel springs • Plugs heat-treated to reduce wear on critical mating surfaces • Interchange with Aro, Foster, Milton as well as units produced by other manufacturers
- Maximum working pressure 300 PSI



Ascot No.	DILL. NO.	MILTON NO.	AMFLO. NO.	SCHRADER No.	THREAD	NPT
COUPLERS						
131-61573	102	715	C20	506089	Female	1/4"
131-61574	103	716	C21	506249	Male	1/4"
ADAPTER PLUGS						
131-61578	110	727	CP21	700677	Male	1/4"
131-61579	109	728	CP20	700688	Female	1/4"

TYPE F

1/2" TRUE-FLATE SERIES

- Brass plated couplers with hardened steel balls and stainless steel springs • Plugs heat-treated to reduce wear on critical mating surfaces • Maximum working pressure 300 PSI



Ascot No.	DILL. NO.	MILTON NO.	AMFLO. NO.	SCHRADER No.	THREAD	NPT
COUPLERS						
133-61563	D-17	1815	C10	503140	Female	1/2"
133-61564	D-16	1816	C9	503104	Male	1/2"
133-61471	D-17R	—	C10R	—	Female	1/2"
ADAPTER PLUGS						
133-61569	D-3F	1818	CP10	700725	Female	1/2"
133-61568	D-2F	1817	CP9	700626	Male	1/2"
133-61474	D-0F	1819	CP9-03	3537	Male	3/8"
133-01855	N/A	1855	N/A	1855	Male	1/4"

TYPE G

3/8" AUTOMOTIVE SERIES

- Brass plated couplers with hardened steel balls and stainless steel springs • Plugs heat-treated to reduce wear on critical mating surfaces • Maximum working pressure 300 PSI



Ascot No.	DILL. NO.	MILTON NO.	AMFLO. NO.	SCHRADER No.	THREAD	NPT
COUPLERS						
132-61476	D-15C	1803	C8	502191	Male	1/4"
132-61478	N/A	1804	C7	502181	Female	1/4"
132-61553	D-15C	1805	C6	502141	Female	3/8"
132-61554	N/A	1806	C5	502105	Male	3/8"
ADAPTER PLUGS						
132-61481	D-1E	1810	CP8	700835	Female	1/4"
132-61480	D-0E	1809	CP7	700750	Male	1/4"
132-61559	D-3E	1808	CP6	700647	Female	3/8"
132-61558	D-2E	1807	CP5	700752	Male	3/8"
133-01855			1855		Male	1/4"



AIR LINE ACCESSORIES



OETIKER 2-EAR CLAMPS

- **Especially suited for industrial or heavy vibrating equipment** • Medium pressure clamp that is used for maintenance and OEM applications • Rubber hose, plastic tubing, coaxial and electrical cable, rope are easily clamped
- **APPLICATIONS:** For air, fluid, gas and steam line



2-Ear Clamps

OETIKER 2-EAR CLAMP SERVICE KIT

- **SERVICE KIT CONTAINS THE FOLLOWING SIZES:** (15) 5/16"; (15) 7/16"; (15) 1/2"; (15) 9/16"; (12) 5/8"; (12) 3/4"; (12) 7/8"; (12) 15/16"; (12) 1"; and (1) pair straight jaw pincers



316-91098

Ascot No.	Description
316-91098	Complete Kit
316-01098	Pincer Only

PINCH CLAMPS

- **Made from stainless steel** • Feature a specialized tongue-in-groove design to provide a tight, secure seal • Tamper evident design • Ideal for both flexible and inflexible thin-walled hoses
- Smooth-edged bandsteel design prevents damage to hoses



316-00102

Pinch Clamp

Ascot No.	Mfg. No.	Nominal Size	Inches Closed-Open	MM Closed-Open	Inner Inches	Width of Ear
316-00507	507	1/4"	.197-.276"	5-7 mm	.236"	6.0 mm
316-00709	709	5/16"	.276-.354"	7-9 mm	.276"	7.0 mm
316-00911	911	7/16"	.355-.433"	9-11 mm	.276"	7.0 mm
316-01113	1113	1/2"	.433-.512"	11-13 mm	.276"	7.0 mm
316-01315	1315	9/16"	.512-.591"	13-15 mm	.295"	7.5 mm
316-01517	1517	19/32"	—	—	—	—
316-01518	1518	5/8"	.591-.708"	15-18 mm	.315"	8.0 mm
316-01720	1720	3/4"	.669-.787"	17-20 mm	.335"	8.5 mm
316-01922	1922	13/16"	.748-.866"	19-22 mm	.354"	9.0 mm
316-02023	2023	7/8"	.787-.905"	20-23 mm	.354"	9.0 mm
316-02225	2225	15/16"	.866-.984"	22-25 mm	.394"	10.0 mm
316-02327	2327	1"	.905-1.063"	23-27 mm	.394"	10.0 mm
316-03740	3740	1-1/2"	—	—	—	—

Ascot No.	Mfg. No.	Description
316-00012	PEC12	1/2" Pinch Clamp
316-00058	PEC58	5/8" Pinch Clamp
316-00078	PEC78	7/8" Pinch Clamp
316-00716	PEC716	7/16" Pinch Clamp
316-00916	PEC916	9/16" Pinch Clamp
316-02332	PEC2332	23/32" Pinch Clamp
316-00102	CSC-102	Handheld Pinch Clamp Crimper

HOSE FITTINGS, CLAMPS & ACCESSORIES



SOLID BRASS FEMALE CROSSES

• Excellent for running several air lines from a common supply hose



136-00344

Ascot No.	Mfg. No.	NPT Thread
136-00344	344X	1/4"
136-00366	366X	3/8"

BRASS IN-LINE SWIVELS

• Simple design is excellent to stop hoses from kinking or for use in pneumatic equipment applications



136-02366

Ascot No.	Mfg. No.	NPT Thread
136-02344	344R	1/4" Male/Female NPT
136-02366	366R	3/8" Male/Female NPT



SOLID BRASS FEMALE TEES

• Use to run two lines from a common feed



136-01366

Ascot No.	Mfg. No.	NPT Thread
136-01344	655	1/4"
136-01366	655-1	3/8"

SOLID BRASS SWIVEL

• Simple design is excellent to stop hoses from kinking or for use in pneumatic equipment applications



136-34490

Ascot No.	Mfg. No.	NPT Thread
136-34490	660	1/4" Male/Female Swivel

STANDARD MALE HOSE BARB FITTINGS

• **Select fitting to match hose ID** • Fittings must be secured to hose with either a hose clamp or crimped-on ferrule



136-71606

Ascot No.	Mfg. No.	NPT Thread	Hose ID
136-00401	600	1/4"	1/4"
136-00604	604	3/8"	1/4"
136-00406	602	1/4"	3/8"
136-00606	603	3/8"	3/8"
136-00806	806	1/2"	3/8"
136-00408	408	1/4"	1/2"
136-00608	604	3/8"	1/2"
136-00808	604-1	1/2"	1/2"
136-71404	07001-0404	1/4"	1/4"
136-71504	07001-0504	5/16"	1/4"
136-71604	07001-0604	3/8"	1/4"
136-71606	07001-0606	3/8"	3/8"
136-71806	07001-0806	1/2"	3/8"
136-71808	07001-0808	1/2"	1/2"

STANDARD FEMALE HOSE BARB FITTING

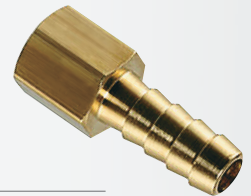

136-72404

Ascot No.	Mfg. No.	NPT Thread
136-72404	07002-0404	1/4" x 1/4" Female Hose Barb



AIR TOOLS & ACCESSORIES

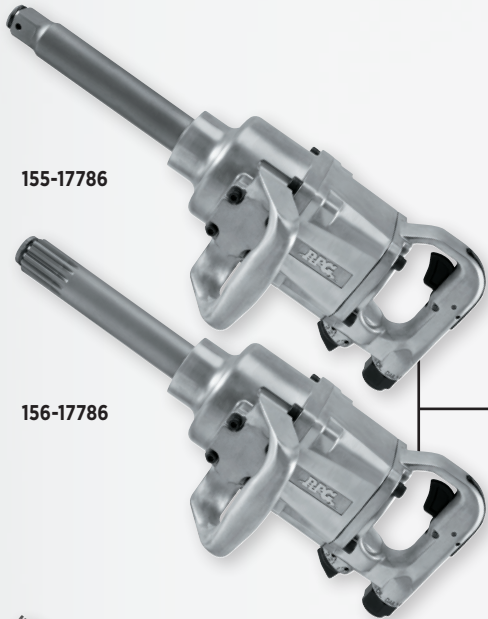

155-17786

156-17786

RPG 1" DRIVE SUPER DUTY AIR IMPACT WRENCH

• **6" extended anvil** • Steel end plates • **WORKING TORQUE RANGE:** 1,600-1,800 ft./lbs. • **FREE SPEED:** 4,500 RPM • **MAXIMUM TORQUE:** 1,800 ft./lbs. • *Replacement parts available**

RPG 1" & #5 SPLINE DRIVE SUPER DUTY IMPACT WRENCH

• **6" extended anvil** • 3-position forward and reverse • High efficiency 6-vane motor • Swoop-back side handle for maneuverability and balance • Pinless clutch mechanism • **WORKING TORQUE RANGE:** 1,800-2,000 ft./lbs. • **FREE SPEED:** 5,000 RPM • **MAXIMUM TORQUE:** 2,000 ft./lbs.



155-26464

RPG 1" DRIVE MINI PLUS AIR IMPACT WRENCH

• **6" extended anvil** • 3-position power setting • Rubber-coated side handle for added comfort • Powered by the twin hammer clutch • **FREE SPEED:** 5,000 RPM • **MAXIMUM TORQUE:** 2,000 ft./lbs.

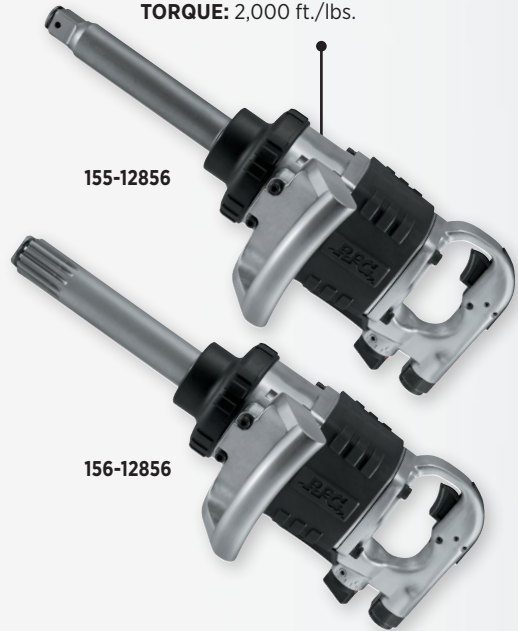

155-12856

156-12856

IMPACT WRENCH SPECIFICATIONS

Ascot No.	Mfg. No.	Square Drive	Free Speed (RPM)	Max Torque (Ft./Lbs.)	Air Pressure (PSI)	Air Con. Avg. (CFM)	Air Inlet (NPT)	Hose Size	Length	Weight (Lbs.)
155-12856	A2856	1"	5,000	2,000	—	12	1/2"	3/4"	20.5"	27.6
155-17786	A778-6	1"	4,500	1,800	90	8.4	1/2"	3/4"	20.3"	26.59
155-26464	A26464	1"	5,000	1,800	90	9	1/2"	3/4"	19.2"	17.86
156-12856	A2856SP	#5 Spline	5,000	2,000	—	12	1/2"	3/4"	20.5"	27.6
156-17786	A778SP-6	#5 Spline	4,500	1,800	90	8.4	1/2"	3/4"	20.3"	26.59

REPLACEMENT PARTS

Ascot No.	Mfg. No.	Description
175-10026	#26	Set of 6 Rotor Blades for A778-6 1" Drive Impact Wrench
175-10037	#37	Hammer for A778-6 1" Drive Impact Wrench
175-10040	#40	Hammer Cage for A778-6 1" Drive Impact Wrench
175-10043	#43	Replacement Side Handle Kit for A778-6 1" Drive Impact Wrench
176-18406	A778-6TK	Tune-Up Kit for A778-6 1" Drive Impact Wrench





AIR TOOLS & ACCESSORIES



RPG 1/2" DRIVE SUPER DUTY AIR IMPACT WRENCH

- 2" extended anvil
- **FREE SPEED:** 8000 RPM
- **MAXIMUM TORQUE:** 600 ft./lbs.
- Proven design and the most popular configuration in the tire service industry
- Powered by the durable and high performing twin hammer mechanism
- Handle exhaust



154-10261



RPG 3/4" DRIVE IMPACT WRENCH

- Short anvil
- 6-position power setting
- **FREE SPEED:** 5,500 RPM
- **MAXIMUM TORQUE:** 1,100 ft./lbs.
- The most powerful 3/4" drive classic wrench
- Suitable for tire or engine work on truck, bus or farm machinery

RPG 1/2" DRIVE COMPOSITE IMPACT WRENCH W/ EXTENDED ANVIL

- Convenient one-hand operated forward/reverse push button
- Four-setting torque adjustment switch
- Compact with a total length of only 7.2"
- Twin hammer mechanism provides smooth balance
- Feather trigger for precise speed control
- Energy efficient motor for maximum performance & long life
- Swivel air inlet prevents hose from twisting



IMPACT WRENCH SPECIFICATIONS

Ascot No.	Mfg. No.	Square Drive	Free Speed (RPM)	Max Torque (Ft./Lbs.)	Air Pressure (PSI)	Air Con. Avg. (CFM)	Air Inlet (NPT)	Hose Size	Length	Weight (Lbs.)
153-22131	SS-A2131-COMP	1/2"	8,000	700	90	4	1/4"	3/8"	7.6"	4.74
153-33120	A2312G	1/2"	8,000	600	90	4	1/4"	3/8"	8-1/8"	5.6
154-10261	A261	3/4"	5,500	1,100	—	9.5	3/8"	1/2"	8.2"	12.9
153-12260	A2131-2COMP	1/2"	7,500	685	90	5	1/4"	3/8"	7.2"	4.5



RPG HIGH SPEED TIRE BUFFER WITH OVERHOSE KIT

- Jacobs chuck for holding buffing accessories • Lock-off throttle • **FREE SPEED:** 22,000 RPM
- **APPLICATIONS:** Tire patchwork, roughing areas for recapping and cleaning tire moldings
- Includes overhose kit



158-10871

RPG HIGH SPEED BUFFER KIT WITH QUICK CHANGE CHUCK

- Quick change chuck for holding buffing accessories
- Lock-off throttle
- **FREE SPEED:** 22,000 RPM
- **APPLICATIONS:** Tire patchwork, roughing areas for recapping and cleaning tire moldings
- Includes overhose kit



158-11871

RPG LOW SPEED TIRE BUFFER WITH QUICK CHANGE SLIP CHUCK

- Brass bushings provide performance and durability in tough working conditions
- Includes whip hose and exhaust hose
- Quick change slip chuck for fast and easy change of buffing wheel
- Built-in regulator
- Lock off throttle to prevent accidental start ups
- Rear exhaust directs air away from the work area
- Ideal for patchwork, roughing areas for recapping and cleaning tire moldings
- Overhose Kit also Available Separately (175-00873)



158-10873

RPG 1/4" MINI ANGLE DIE GRINDER

- Compact, lightweight design for easy use
- **APPLICATIONS:** High speed blending, smoothing, porting and deburring in confined areas
- Right angle for easy maneuvering
- **FREE SPEED:** 22,000 RPM



157-10875

TIRE BUFFER SPECIFICATIONS

Ascot No.	Mfg. No.	Description	Free Speed (RPM)	Length
158-10873	A873K	Low Speed Tire Buffer with Quick Change Chuck	2,800	1.75"
158-10871	A871K	High Speed Tire Buffer with Overhose Kit	22,000	2.5"
158-11871	A871K-QC	High Speed Buffer Kit with Quick Change Chuck	22,000	1.75"
157-10875	A875	RPG 1/4" Mini Angle Die Grinder	22,000	5"



AIR TOOLS & ACCESSORIES

RPG 3" CUT-OFF TOOL

Adjustable speed regulator for precise control • Lock-off throttle to prevent accidental start-up • Rear exhaust directs air away from work area • Durable gears for top performance and long life
• FREE SPEED: 22,000 RPM



157-10874

Ascot No.	Mfg. No.	Description
157-10874	A874	3" Cut-Off Tool

MOBILE WHEEL WORK STATION

- Features gas-strut assisted boom that supports the weight of those heavy impact wrenches
- The suspended impact wrench is capable of rotating to the operator desired position
- Features side and rear storage compartments designed to organize sockets, tire irons, lubricants, hoses and various wheel parts
- Air wrench is supported and held in desired position
- Air wrench suspension boom allows for directional freedom and reduces damage

Ascot No.	Mfg. No.	Description
515-00555	WS-005	Mobile Wheel Work Station

RPG 1/2" REVERSIBLE AIR DRILL

• **Quick change chuck retainer** • Exhaust hose • Side handle • **FREE SPEED: 500 RPM** • **CHUCK SIZE: 1/2"** • Swivel air inlet for ease of use



175-01035



175-11035



157-01035

REPLACEMENT PARTS FOR 1/2" REVERSIBLE AIR DRILL

Ascot No.	Mfg. No.	Description
175-01035	253340	Side Handle Kit for A1035 Air Drill
175-11035	H025	Air Hose Exhaust Kit for A1035 Air Drill
157-01035	A1035	1/2" Air Drill w/ Quick Change Chuck and Exhaust Hose



515-00555



**Chicago
Pneumatic**



153-07336

**NEW GRIP
& TRIGGER**

1/2" SUPER DUTY AIR IMPACT WRENCH-TIRE TOOL

- Patented spring hammer clutch for smooth operation and extended durability
- Low air consumption and high torque make this tool very efficient
- **ULTIMATE TORQUE:** 665 ft./lb.
- Comfort and control with new ergonomic grip and trigger
- **SUITED FOR ALL MAINTENANCE APPLICATIONS:** Light vehicle tire changing operations, light vehicle mechanical repair, MRO applications

Ascot No.	Mfg. No.	Description
153-00736	CP7736	1/2" Super Duty Air Impact Wrench-Tire Tool
153-07336	CP7736-2	2" Extended Anvil



153-17492



1/2" SUPER DUTY AIR IMPACT WRENCH

- Tackle the tough jobs with the power and speed of this true workhorse
- Patented clutch provides smooth operation and extreme durability
- One hand push button forward reverse power regulator
- 4 positive power settings in forward and ultimate power in reverse
- Compact design with comfortable contoured handle
- **ULTIMATE TORQUE:** 610 ft./lb.

Ascot No.	Mfg. No.	Description
153-07492	CP-749	1/2" Impact Wrench
153-17492	CP-749-2	2" Extended Anvil



153-07748



153-77482

1/2" SUPER DUTY AIR IMPACT WRENCH-TIRE TOOL

- 960 ft./lb. of torque (1,300 Nm)
- Hard anodized end plates
- Hard chromium aluminum cylinder
- Twin hammer mechanism
- Lightweight due to the Composite motor housing
- **COMPACT:** Only 6.6" long
- Curved handle with rubber material resistant to most chemicals used in workshops
- Full teasing trigger
- 360° swivel air inlet
- Friction ring socket retainer

Ascot No.	Mfg. No.	Description
153-07748	CP7748	1/2" Super Duty Air Impact Wrench-Tire Tool
153-77482	CP7748-2	2" Extended Anvil



153-77492

**FEATURES
S2S (SIDE-
TO-SIDE)**

**PERFECT
BALANCE**

1/2" HEAVY DUTY AIR IMPACT WRENCH

- Side-To-Side (S2S) forward/reverse functionality
- Perfectly balanced to reduce strain on wrist and forearm
- Twin hammer mechanism
- **ULTIMATE TORQUE:** 955 ft./lb

Ascot No.	Mfg. No.	Description
153-07749	CP7749	1/2" Impact Wrench
153-77492	CP7749-2	2" Extended Anvil



AIR TOOLS & ACCESSORIES

3/4" HEAVY DUTY AIR IMPACT WRENCH

- Smoothest operating 3/4" impact on the market
- One hand push button forward/reverse power regulator
- Handle exhaust with 360° air inlet swivel
- **APPLICATIONS:** spring work, truck and bus maintenance, farm machines & construction equipment
- **ULTIMATE TORQUE:** 1,000 ft./lbs.

Ascot No.	Mfg. No.	Description
154-00772	CP772H	3/4" Impact Wrench
154-01772	CP772H-6	6" Extended Anvil



154-01772

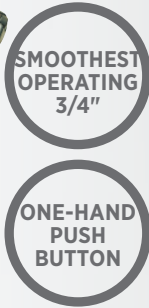

3/4" SUPER DUTY AIR IMPACT WRENCH - "D" HANDLE

- Great performance
- Lightweight
- Comfort
- Easy to use
- Rugged and robust
- Easy operation
- 1300 ft./lbs. - 1760 Nm of maximum torque in reverse

Ascot No.	Mfg. No.	Description
154-27763	CP7763D	1" Short Shank
154-37763	CP7763D-6	6" Extended Anvil



154-37763

1" SUPER DUTY AIR IMPACT WRENCH

- 14.5 lbs. (6.6 kg)
- Twin hammer mechanism
- Steel motor
- Intuitive forward/reverse lever & power regulator on both sides
- 4-position power settings on both sides
- Down exhaust
- Side handle with soft touch grip
- Aluminum housing
- Composite cover on the clutch housing
- Socket retainer ring
- 1300 ft./lbs. - 1760 Nm maximum torque in reverse

Ascot No.	Mfg. No.	Description
155-07773	CP7773D	1" Short Shank
155-77736	CP7773D-6	6" Extended Anvil



155-77736

1" HEAVY DUTY AIR IMPACT WRENCH

- 2140 ft./lbs. 2900 Nm of maximum torque in reverse
- Pinless closed reinforced rocking dog impact mechanism
- Socket retainer ring combined with hole retainer
- Ergonomic side handle
- Full teasing trigger
- Regulator with integrated forward/reverse with 3-position power settings in both directions

Ascot No.	Mfg. No.	Description
155-07782	CP-7782	1" Short Anvil
155-77826	CP-7782-6	6" Extended Anvil
155-17782	CP-7782-SP6	#5 Spline with 6" Extended Anvil



155-77826



155-17782

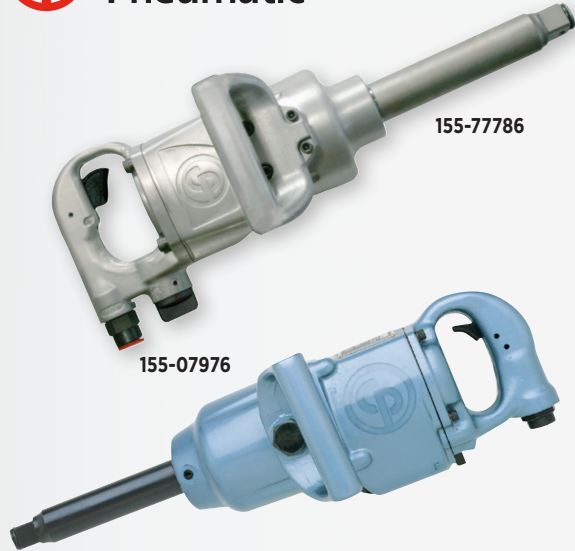

1" NON-IMPACT WRENCH (BLUE TORK)

- Two pneumatic motors for rundown and final tightening
 - Preset and adjustable shut off for torque control
 - Quality: Precise, accurate tightening to the manufacturer's recommended torque and angle specifications
 - Environment
- Improvements: by increasing durability of the tools, we reduce waste
- ERGONOMICS: very low noise level, virtually no vibration
 - EFFICIENCY: Precise and accurate tightening, less fatigued operators
 - Maximum Torque: 660 ft./lb.

168-07600

Training required prior to use.



Ascot No.	Mfg. No.	Description
168-07600	CP7600xB	Non-Reversible Single Torque Preset
168-07602	CP7600xB-R	Reversible Single Torque Preset
168-07603	CP7600xB-R4P	Reversible 4 Torque Preset Selector

1" HEAVY DUTY AIR IMPACT WRENCH

- High performance clutch provides longer life under tough conditions
- High-efficiency 6 vane motor for maximum performance
- Bottom exhaust directs exhaust away from the operator
- Three position power regulator with directional control
- **ULTIMATE TORQUE:** 1,450 ft./lbs.

Ascot No.	Mfg. No.	Description
155-07778	CP-7778	1" Short Shank
155-77786	CP-7778-6	6" Extended Anvil
155-27786	CP-7778SP-6	#5 Spline with 6" Extended Anvil

1" SUPER DUTY AIR IMPACT WRENCH

- Rocking dog clutch for smooth operation and extreme durability
- Teasing throttle for easy bolt starting
- Convenient reverse valve for easy directional changes
- Choice of professional mechanics for high volume tire work on trucks, buses and heavy equipment
- **ULTIMATE TORQUE:** 1,400 ft./lbs.

Ascot No.	Mfg. No.	Description
155-07971	CP-797	1" Short Shank
155-07976	CP-797-6	6" Extended Shank
156-79716	CP-797SP-6	6" Extended Shank and #5 Spline

HIGH SPEED TIRE BUFFER KIT

- Jacobs chuck for holding buffing accessories • Lock-off throttle
- **APPLICATIONS:** Tire patchwork, roughing areas for recapping and cleaning tire moldings • **FREE SPEED:** 22,000 RPM



Ascot No.	Mfg. No.	Description
158-00871	CP871K	Includes Over Hose
158-01871	CP871	High Speed Tire Buffer Only
158-02871	CP871-QC	High Speed Tire Buffer w/ Quick Change Chuck

LOW SPEED TIRE BUFFER KIT

- Quick change slip chuck for fast and easy change of buffing wheel • Adjustable speed regulator for precise control • Lock off throttle to prevent accidental start ups • Rear exhaust directs air away from work area • **FREE SPEED:** 2,800 RPM



Ascot No.	Mfg. No.	Description
158-00873	CP873K	Includes Over Hose
158-01873	CP873	Low Speed Tire Buffer Only



AIR TOOL ACCESSORIES



CORDLESS 1/2" DRIVE IMPACT WRENCH

- **4 CUSTOMIZABLE MODES:** Provides multiple fastening torque outputs designed for sedans, light trucks and box trucks
- **POWERSTATE™ BRUSHLESS MOTOR:** Delivers up to 750 ft./lb. of fastening torque and 1,100 ft./lb. of nut-busting torque
- **LONG MOTOR LIFE:** POWERSTATE™ Brushless Motor delivers maximum power and long motor life
- **FASTER TIRE SERVICE:** Enables users to perform faster tire service by removing the hassle of pneumatic hoses, compressors, and torque sticks
- **PART OF THE M18™ SYSTEM:** Featuring over 175+ Tools



153-76920

LONG MOTOR LIFE

PART OF THE M18™ SYSTEM

CORDLESS 1" DRIVE IMPACT WRENCH

- **POWERSTATE™ BRUSHLESS MOTOR:** Delivers up to 1,800 ft./lb. nut-busting torque, making it the world's most powerful cordless impact wrench
- Up to 7 lb. lighter weight allowing for less user fatigue
- **ONE-KEY™ COMPATIBLE:** Ability to customize, track and manage tools for increased productivity and investment protection
- **4-MODE DRIVE CONTROL™:** Provides greater control over output speed and power
- **LOWER OWNERSHIP COST:** Eliminates compressors and generators, providing greater portability and lower cost of ownership
- Includes the ability to set a repeatable torque output for maximum control

LONG MOTOR LIFE



155-86720

PART OF THE M18™ SYSTEM



153-76922



155-86722

Ascot No.	Mfg. No.	Description
153-76920	2769-20	Cordless 1/2" Drive Impact Wrench - 2" Extended Anvil (Bare Tool)
153-76922	2769-22	Cordless 1/2" Drive Impact Wrench - 2" Extended Anvil (Kit)

Ascot No.	Mfg. No.	Description
155-86720	2867-20	Cordless 1" Drive Impact - Standard Anvil (Bare Tool)
155-86722	2867-22	Cordless 1" Drive Impact - Standard Anvil (Kit)



MILWAUKEE 1" DRIVE EXTENDED ANVIL D-HANDLE IMPACT WRENCH

- POWERSTATE™ Brushless Motor delivers up to 2,000 ft-lbs of nut-busting torque and 1,900 ft-lbs of fastening torque
- Install up to 200 1-1/4" bolts on a single HIGH OUTPUT™ HD12.0Ah battery
- M18™ REDLITHIUM™ Battery Packs are compatible with all M18™ tools
- The 4-Mode DRIVE CONTROL™ provides you with greater control over the output speed and power of the MILWAUKEE® High Torque Impact Wrench
- The ONE-KEY™ Technology allows you to customize, track, and manage the impact wrench with the ability to set a repeatable torque output for maximum control



MILWAUKEE 1" DRIVE STANDARD ANVIL D-HANDLE IMPACT WRENCH

- POWERSTATE™ Brushless Motor delivers up to 2,000 ft-lbs of nut-busting torque and 1,900 ft-lbs of fastening torque
- Install up to 200 1-1/4" bolts on a single HIGH OUTPUT™ HD12.0Ah battery
- M18™ REDLITHIUM™ Battery Packs are compatible with all M18™ tools
- The 4-Mode DRIVE CONTROL™ provides you with greater control over the output speed and power of the MILWAUKEE® High Torque Impact Wrench
- The ONE-KEY™ Technology allows you to customize, track, and manage the impact wrench with the ability to set a repeatable torque output for maximum control



Ascot No.	Mfg. No.	Description
155-86922	2869-22	1" Drive Extended Anvil D-Handle Impact Wrench - Kit Kit Includes: (1) M18 FUEL™ 1" D-Handle High Torque Impact Wrench w/ ONE-KEY™ (2868-20) (2) M18 REDLITHIUM™ HIGH OUTPUT™ HD12.0 Battery Pack (48-11-1812) (1) M18™ & M12™ Rapid Charger (48-59-1808) (1) Adjustable Handle (1) Lanyard Loop (1) Contractor Bag
155-86920	2869-20	1" Drive Extended Anvil D-Handle Impact Wrench - Bare Tool Only

Ascot No.	Mfg. No.	Description
155-86822	2868-22	1" Drive Standard Anvil D-Handle Impact Wrench - Kit Kit Includes: (1) M18 FUEL™ 1" D-Handle High Torque Impact Wrench w/ ONE-KEY™ (2868-20) (2) M18 REDLITHIUM™ HIGH OUTPUT™ HD12.0 Battery Pack (48-11-1812) (1) M18™ & M12™ Rapid Charger (48-59-1808) (1) Adjustable Handle (1) Lanyard Loop (1) Contractor Bag
155-86820	2868-20	1" Drive Standard Anvil D-Handle Impact Wrench - Bare Tool Only



AIR TOOL ACCESSORIES



3/4" SUPER DUTY AIR IMPACT WRENCH

- Powerful 3/4" wrench
- Ideal for everything from spring work to pinion nut and track pad removal and major engine teardowns
- Combines compact size with high output
- Jumbo hammer mechanism delivers up to 1,100 ft./lbs. of torque smoothly, with less vibration

Ascot No.	Mfg. No.	Description
154-00261	IR-261	Standard Anvil
154-02613	IR-261-3	3" Extended Anvil
154-02616	IR-261-6	6" Extended Anvil

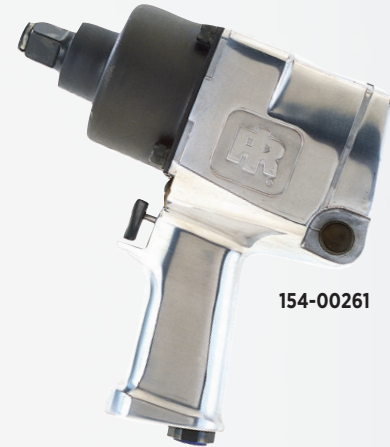

154-00261

3/4" ULTRA DUTY AIR IMPACT WRENCH

- Offers all of the ergonomic, power and durability enhancing features as the IR-2161 but with a 6" extended anvil for those hard to reach applications
- Jumbo hammer mechanism
- Up to 1,200 ft./lbs. of torque
- Trouble-free, longer performance aided by the pressure-feed lube system
- Compact and only 7-5/8" long
- Handle exhaust

Ascot No.	Mfg. No.	Description
154-21617	IR-2161XP-6	3/4" Ultra Duty Air Impact Wrench



154-21617

1/2" SUPER DUTY AIR IMPACT WRENCH

- Offers the sheer power and performance features to tackle the toughest of jobs
- Most popular tool in its class
- Durable and economical
- **TORQUE RANGE:** 25-350 ft./lbs.

Ascot No.	Mfg. No.	Description
153-00231	IR-231HA	Standard Anvil
153-02312	IR-231HA-2	Extended Anvil



153-00231

1/2" ULTRA DUTY TITANIUM AIR IMPACT WRENCH

- Titanium weighs less and provides greater durability
- Enhanced Twin Hammer mechanism for fast removal of frozen bolts
- Push button forward/reverse controls for one-handed operation
- **TORQUE RANGE:** 50-600 ft./lb., 625 ft./lb. max (forward), 700 ft./lb. max (reverse)

Ascot No.	Mfg. No.	Description
153-02235	IR-2235TiMAX	Standard Anvil
153-12235	IR-2235TiMAX-2	2" Extended Anvil
153-32235	IR-2235QTiMAX	Quiet Version
153-22235	IR-2235QTiMAX-2	Quiet Version with 2" Extended Anvil



153-12235



1" HEAVY DUTY AIR IMPACT WRENCH

- 1" drive wrench with 1,000 ft./lbs. torque to handle tough jobs in cramped spaces
- Built-in pressure-feed lube system, adjustable side handle and built-in oil reservoir that provides continuous misting of the air motor
- Available in 6" extended anvil and 6" extended #5 spline drive anvil for high production truck tire changing

Ascot No.	Mfg. No.	Description
155-00280	IR-280	Standard Anvil
155-02806	IR-280-6	6" Extended Anvil
156-28006	IR-280-S6	#5 Spline Super Duty Anvil

1" HEAVY DUTY AIR IMPACT WRENCH

- Perfect for the demanding world of truck tire and service work
- Combines exceptional power, durability and operator convenience
- Delivers 1450 ft./lbs. of maximum torque, with a 5000 RPM free speed and four-position power regulator 360° swivel inlet
- Available in 6" extended anvil and 6" extended #5 spline drive anvil for high production truck tire changing

Ascot No.	Mfg. No.	Description
155-28560	IR-285B	Standard Anvil
155-02856	IR-285B-6	6" Extended Anvil
156-28566	IR-285BS-6	#5 Spline Super Duty Anvil

1" D-HANDLE IMPACT WRENCH

- **SOLID STEEL IMPACT MECHANISM:** Deliver 2,100 ft./lb. of torque
- **HIGHLY ENGINEERED DESIGN:** Delivers the power you need over the life of the tool
- **STEEL CORE DESIGN:** Nothing's been proven to last longer
- **CHEMICAL RESISTANT HOUSING & STEEL CORE:** Stands up to drops and harsh work environments
- **LIGHTWEIGHT:** 25% lighter than the industry's leading 1" wrench
- **360° ADJUSTABLE HANDLE:** The side handle rotates fully around the tool as the job demands
- **SWIVEL HOSE CONNECTION:** Keeps cords from getting tangled so you can move freely around the garage
- **6" ANVIL EXTENSION:** Increases accessibility in hard to reach places

Ascot No.	Mfg. No.	Description
155-02850	IR-2850MAX	Standard Anvil
155-28506	IR-2850MAX-6	Extended Anvil

1" HEAVY DUTY AIR IMPACT WRENCH

- Improved 1" drive tool perfect for truck and heavy equipment maintenance
- Offers power and convenience at an affordable price
- Compact, lightweight and perfect for working on suspension components
- TORQUE RANGE: 100-1000 ft./lb.

Ascot No.	Mfg. No.	Description
155-00295	IR-295	Standard Anvil
156-02951	IR-295-S	#5 Spline Drive

HEAVY DUTY AIR LOW SPEED TIRE BUFFER

- **APPLICATIONS:** For quick work of patchwork and roughing up low areas for recapping, tire scuffing and cleaning tire moldings
- **FREE SPEED:** up to 3,000 RPM

Ascot No.	Mfg. No.	Description
157-01327	IR-327LS	Heavy Duty Air Low Speed Tire Buffer, includes Over Hose

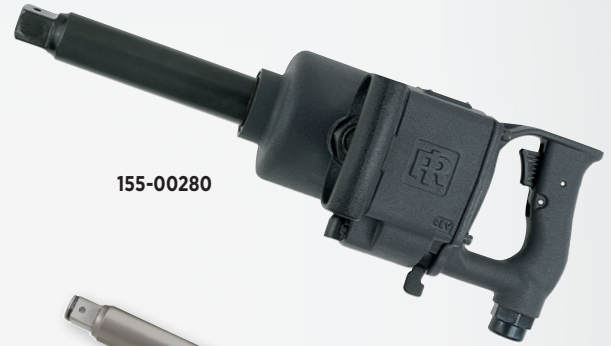

155-00280



155-02856



155-02850



155-28506

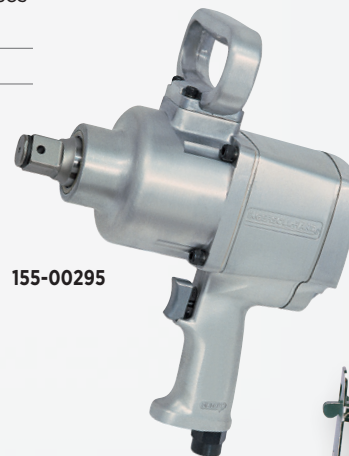

155-00295



157-01327



AIR TOOL ACCESSORIES



AIR TOOL LUBRICANTS

Ascot No.	Mfg. No.	Description
181-10510	105-LBK1	4 Oz. IR 105 Grease, 4 oz. IR10 Oil & Grease Gun Head
181-10540	105-4T	(6) 4 oz. Tubes - IR 105 Grease Refills
181-11510	115-LBK1	4 oz. IR 115 Grease, 4 oz. IR10 Oil & Grease Gun Head
181-11540	115-4T	(6) 4 oz. Tubes - IR 115 Grease Refills
181-12228	R000A2-228	Grease Gun
328-10001	100-1	1 lb. Grease for Impact Wrenches



181-10510

MOTOR TUNE-UP KITS

• INCLUDES: the vanes, gaskets and seals for a complete tune-up • 231-TK3 also includes ball bearings

IR No.	Kit No.	Ascot No.
212	212-TK2	176-10212
231C, 231HA-2	231-TK3	176-10221
235	235-TK3	176-12313
244A, 244A-2	244-TK2	176-10244
261, 271	261-TK2	176-10261
280 Series	280-TK2	176-10280
7803A, 7803RA	7803-TK1	176-17803
285B-6	285B-TK1	176-10285
2235TiMAX	2235-TK1	176-22235
2135QXPA, 2135QXPA-2	2135-TK2	176-32135

AIR TOOL COVERS

• Vinyl boots also absorb some of the tool vibration and protect air impact ratchets, wrenches and drills from external damage

IR Tool No.	KIT No.	Ascot No.
212	212-Boot	176-20232
211	211-P32	176-21132
231C, 231HA-2	231-Boot	176-23122
2235	2235M-Boot	176-13532
244A, 244A-2	244-Boot	176-24432
261, 261-2, 271	261-Boot	176-26132
285B-6, 285BS-6, 285B	285-Boot	176-28532
259	259-Boot	176-25925
2135QXPA, 2135QXPA-2	2135M-Boot	176-21350

IMPACT WRENCH ACCESSORIES

Ascot No.	Mfg. No.	Description
175-23142	IR 231-425	IR 1/2" Impact Wrench Retainer Clip
175-33104	231-Boot	Red Protective Boot for IR 231HA-2 Impact Wrenches
175-82651	H-082651	1" Impact Wrench Retainer Clip O-Ring
175-83071	P-08371	O-Ring for 1/2" Impact Wrench Retainer Clips



INDUSTRIAL STRENGTH SILICONE LUBRICANT

• Teflon™ fluoropolymer enhances performance
 • Long-lasting lubrication • Won't accumulate • dust & dirt
 • QUANTITY: 12 per case



328-00016

Ascot No.	Mfg. No.	Description
328-00016	16-SL	Blaster Silicone Lubricant - 11 Oz.

RETAINING RINGS

IR No.	Ascot No.	Description
231-425A	175-31425	Socket Retainer for IR231, 231-2
R1A-159	175-01590	Retainer O-Ring for IR 231, 231-2
291-425	175-91425	Socket Retainer for IR-281, 285
291-426	175-81426	Retainer O-Ring for IR-281, 285

MARVEL AIR TOOL OIL

- **APPLICATIONS:** Specially formulated for use in all piston type rotary air tools and in-line air lubricators
- Assures maximum performance by dissolving gum and sludge
- Prevents rust formation while providing positive lubrication for smooth starting and longer tool life
- **QUANTITY:** 6 bottles per case

Ascot No.	Mfg. No.	Description
181-00085	MM085	Marvel Air Tool Oil, 32 Oz.



181-00080
Marvel Air Tool Oil



181-00085
Marvel Air Tool Oil



MARVEL AIR TOOL OIL

- 12 Bottle per case
- 4 oz. bottles
- Specifically formulated for use in all air tools or in-line lubricators
- Prevents rust
- Assures maximum tool performance
- Made in the U.S.A

Ascot No.	Mfg. No.	Description
181-00080	3125	Marvel Air Tool Oil 4 Oz.



181-00406
Super Red Pneumatic Air Tool Lubricant

SUPER RED PNEUMATIC AIR TOOL LUBRICANT

- **APPLICATIONS:** Dissolves gum & varnish formation
- Prevents gum & varnish formation
- Ensures smoother starts
- Special rust & oxidation inhibitor
- Clean and free running
- **QUANTITY:** 12 bottles per case

Ascot No.	Mfg. No.	Description
181-00406	0406	Super Red Pneumatic Air Tool Oil



181-00404

181-01404

B'LASTER AIR TOOL CONDITIONER

- **APPLICATIONS:** Thoroughly cleans internal pneumatic tool parts, restoring them to peak performance and prolonging tool life • Breaks loose deposits that create friction and impede smooth operation
- Provides long-lasting lubrication
- Protects tools from freezing down to -25°F • **12 cans per case**

Ascot No.	Mfg. No.	Description
181-00404	16-ATL	Blaster Air Tool Conditioner - 16 Oz.
181-01404	ATC-TS	Blaster Air Tool Conditioner - 3.5 Oz. Aerosol



181-00016

B'LASTER AIR TOOL OIL/LUBE

- **APPLICATIONS:** Provides lubrication & prolongs tool life
- Improves tool performance
- Formulated for use with in-line oilers • **12 cans per case**

Ascot No.	Mfg. No.	Description
181-00016	16-ATL	Blaster Air Tool Oil/Lube - 16 Oz.

IMPACT SOCKET



IMPACT SOCKET SETS



Ascot No.	Mfg. No.	Description	Details
163-01150	1150	1/2" DR 13-Piece SAE Set	<ul style="list-style-type: none"> Contains the following sizes: 7/16", 1/2", 9/16", 5/8", 11/16", 3/4", 13/16", 7/8", 15/16", 1", 1-1/16", 1-1/8", 1-1/4"
163-01151	1151D	1/2" DR 13-Piece Deep Set	<ul style="list-style-type: none"> Contains the following sizes: 7/16", 1/2", 9/16", 5/8", 11/16", 3/4", 13/16", 7/8", 15/16", 1", 1-1/16", 1-1/8", 1-1/4"
163-01152	1152M	1/2" DR 14-Piece Metric Standard Set	<ul style="list-style-type: none"> Contains the following sizes: 10mm, 11mm, 12mm, 13mm, 14mm, 15mm, 16mm, 17mm, 18mm, 19mm, 21mm, 22mm, 26mm, 27mm
163-01153	1153MD	1/2" DR 14-Piece Metric Deep Set	<ul style="list-style-type: none"> Contains the following sizes: 10mm, 11mm, 12mm, 13mm, 14mm, 15mm, 16mm, 17mm, 18mm, 19mm, 21mm, 22mm, 26mm, 27mm
163-02668	2668	1/2" DR Master 39-Piece SAE Impact Socket Set	<ul style="list-style-type: none"> CR-MO alloy steel for long life Fully guaranteed Heavy duty blow mold case 19 Standard Sockets: 3/8", 7/16", 1/2", 9/16", 5/8", 11/16", 3/4", 13/16", 7/8", 15/16", 1", 1-1/16", 1-1/8", 1-3/16", 1-1/4", 1-5/16", 1-3/8", 1-7/16" and 1-1/2" 19 Deep Sockets: 3/8", 7/16", 1/2", 9/16", 5/8", 11/16", 3/4", 13/16", 7/8", 15/16", 1", 1-1/16", 1-1/8", 1-3/16", 1-1/4", 1-5/16", 1-3/8", 1-7/16" and 1-1/2" Universal
163-02669	2669	1/2" DR Master 39-Piece Metric Impact Socket Set	<ul style="list-style-type: none"> CR-MO alloy steel for long life Fully guaranteed Heavy duty blow mold case 19 Standard Sockets: 9mm, 10mm, 11mm, 12mm, 13mm, 14mm, 15mm, 16mm, 17mm, 18mm, 19mm, 20mm, 21mm, 22mm, 23mm, 24mm, 26mm, 27mm and 30mm 19 Deep Sockets: 9mm, 10mm, 11mm, 12mm, 13mm, 14mm, 15mm, 16mm, 17mm, 18mm, 19mm, 20mm, 21mm, 22mm, 23mm, 24mm, 26mm, 27mm and 30mm Universal Joint
163-05153	1153DD	1/2" DR 29-Piece Metric and SAE 6 Point Deep Impact Socket Set	<ul style="list-style-type: none"> Contains the following sizes: 7/16", 1/2", 9/16", 5/8", 11/16", 3/4", 13/16", 7/8", 15/16", 1", 1-1/16", 1-1/8" and 1-1/4" deep sockets 10, 11, 12, 13, 14, 15, 16, 17, 18, 19, 21, 22, 26 and 27mm deep sockets 3/4" x 13/16" deep and 19mm x 21mm deep flip sockets
163-22219	122019K2	1/2" Dr. 4-Piece Flank Bite Damaged Nut Remover Socket Set	<ul style="list-style-type: none"> New Flank Bite design works on up to an industry leading 90% rounded lug nut Also safe for forward tightening of lug nuts without damage Contains the following sizes: 17mm, 19mm, 21mm, 22mm Individual sockets also available separately: 17mm (163-22017), 19mm (163-22019), 21mm (163-22021), 22mm (163-22022)
164-02110	2110	3/4" DR 10-Piece Truck Set	<ul style="list-style-type: none"> Contains the following sizes: 13/16" Square Socket, 1-1/16", 1-1/8", 1-1/4" Thin Wall Deep Sockets, 1-1/2" Budd Wheel Socket, 17mm & 21mm Square Socket, 33mm, 35mm & 41mm Deep Sockets
164-02181	2181D	3/4" DR 8-Piece SAE Deep Set	<ul style="list-style-type: none"> Contains the following sizes: 1", 1-1/16", 1-1/8", 1-1/4", 1-5/16", 1-3/8", 1-7/16", 1-1/2"
165-03110	3110	1" DR 10-Piece Truck Set	<ul style="list-style-type: none"> Contains the following sizes: 13/16" square, 1-1/16", 1-1/8", 1-1/4" thin wall deep, 1-1/2" deep with inside lip, 17mm & 21mm square with inside lip, 33mm, 35mm & 41mm deep

IMPACT SOCKET SETS (CONT.)

Ascot No.	Mfg. No.	Description	Details
165-03119	3119	1" DR 9-Piece Large Truck Socket Set	<ul style="list-style-type: none"> Contains the following sizes: 13/16" & 15/16" square, 33mm, 1-1/2", 1-5/8", 1-3/4", 1-7/8", 2" & 2-1/2" deep sockets
165-03190	3190	1" DR 9-Piece SAE Truck Set	<ul style="list-style-type: none"> Contains the following sizes: 13/16", 4 points budd wheel standard length, 7/8", 15/16", 1", 1-3/16", 1-1/2" deep with inside lip, 1-1/16", 1-1/8", 1-1/4" thin wall deep
165-03197	3197M	1" DR 7-Piece Metric Truck Set	<ul style="list-style-type: none"> Contains the following sizes: 17mm, 21mm, 4 pts. budd wheel standard length, 27mm, 33mm, 36mm, 41mm deep
165-05626	5626	1" DR 5-Piece Budd Wheel Socket Set	<ul style="list-style-type: none"> Contains the following sizes: 1-1/2" hex x 13/16" square budd wheel impact socket, 35mm x 17mm square budd wheel impact socket, 38mm x 20mm square budd wheel impact socket, 41mm x 21mm square budd wheel impact socket and 33mm deep
166-04191	4191	#5 Spline DR 9-Piece SAE Truck Set	<ul style="list-style-type: none"> Contains the following sizes: 13/16", 4 points budd wheel standard length, 7/8", 15/16", 1", 1-3/16", 1-1/2" deep with inside lip, 1-1/16", 1-1/8", 1-1/4" thin wall deep
167-12030	1203D	1/2" Drive 3-Piece Flip Impact Socket Set	<ul style="list-style-type: none"> CR-MO steel for long life Fully guaranteed Heavy duty blow mold case Contains the following sizes: 3/4" x 13/16" - 1246DT, 19mm x 21mm - 1291DT
167-12050	1205D	1/2" Drive 5-Piece Deep Thin Wall Flip Set	<ul style="list-style-type: none"> Contains the following sizes: 3/4" x 13/16", 19mm x 21mm, 7/8" x 15/16", 17mm x 19mm, 3" extension
167-12051	000524	1/2" Drive 5-Piece 1/2 Size Flip Socket Set	<ul style="list-style-type: none"> Made from durable chromoly steel Coated with a rust and corrosion resistant black oxide finish Contains the following sizes: 18.5mm x 19.5mm, 21mm x 21.5mm, 21.5mm x 22.5mm, 22mm x 22.5mm, Extractor punch Individual sockets also available separately
169-01234	1234A	4-Piece Impact Adapter Socket Set	<ul style="list-style-type: none"> CR-MO steel for long life Heavy duty blow molded case Contains the following: 1/2" (F) x 3/4" (M) adapter, 3/4" (F) x 1" (M) adapter, 3/4" (F) x 1/2" (M) adapter, 1" (F) x 3/4" (M) adapter
492-00502	TSS5	5-Piece 1/2" Drive Twist Socket Set	<ul style="list-style-type: none"> Designed to easily remove damaged, rounded nuts Use with 1/2" drive impact wrench or breaker bar CR-MO steel for long life Heavy duty blow molded case INCLUDES: 17mm, 19mm, 21mm & 22mm twist sockets plus a 50mm extractor punch



402-01283

492-00502

IMPACT SOCKETS



Ascot No.	Mfg. No.	Description
METRIC		
163-10130	1013M	1/2" Drive x 13mm Std.
163-10142	1014M	1/2" Drive x 14mm Std.
163-10162	1016M	1/2" Drive x 16mm Std.
163-10170	1017M	1/2" Drive x 17mm Std.
163-10182	1018M	1/2" Drive x 18mm Std.
163-10190	1019M	1/2" Drive x 19mm Std.
163-10210	1021M	1/2" Drive x 21mm Std.
163-10221	1022M	1/2" Drive x 22mm Std.
163-10270	1027M	1/2" Drive x 27mm Std.
SAE		
163-10180	1018	1/2" Drive x 9/16" Std.
163-10200	1020	1/2" Drive x 5/8" Std.
163-10220	1022	1/2" Drive x 11/16" Std.
163-10240	1024	1/2" Drive x 3/4" Std.
163-10280	1028	1/2" Drive x 7/8" Std.
163-01030	1030	1/2" Drive x 15/16" Std.
163-10360	1036	1/2" Drive x 1-1/8" Std.

Ascot No.	Mfg. No.	Description
METRIC		
163-10172	1017MEDT	1/2" Drive x 17mm Extra Thin Wall
163-10174	1017MEDTM	1/2" Drive x 17mm Extra Thin Wall Mercedes
163-10183	1018MEDT	1/2" Drive x 18mm Extra Thin Wall
163-10191	1019MEDT	1/2" Drive x 19mm Extra Thin Wall
163-10211	1021MEDT	1/2" Drive x 21mm Extra Thin Wall
163-10223	1022MEDT	1/2" Drive x 22mm Extra Thin Wall
163-10230	1023MEDT	1/2" Drive x 23mm Extra Thin Wall
SAE		
163-10241	1024EDT	1/2" Drive x 3/4" Extra Thin Wall
163-10261	1026EDT	1/2" Drive x 13/16" Extra Thin Wall
163-10282	1028EDT	1/2" Drive x 7/8" Extra Thin Wall

Ascot No.	Mfg. No.	Description
METRIC		
167-12110	1211D	1/2" Dr. x 11mm x 12mm Chrome Deep Flip
167-12179	1271DT	1/2" Dr. x 17mm x 19mm Deep Thin Flip
167-12910	1291	1/2" Dr. x 19mm x 21mm Std. Flip
167-12911	1291D	1/2" Dr. x 19mm x 21mm Deep Flip
167-12912	1291DT	1/2" Dr. x 19mm x 21mm Deep Extra Thin Flip
167-18195	1A7535	1/2" Dr. x 18.5mm x 19.5mm Deep Flip
167-21215	1A7538	1/2" Dr/ x 21mm x 21.5mm Deep Flip
167-21225	1A7542	1/2" Dr. x 21.5mm x 22.5mm Deep Flip
167-22225	1A7540	1/2" Dr. x 22mm x 22.5mm Deep Flip
SAE		
167-12460	1246D	1/2" Dr. x 3/4" x 13/16" Deep Flip
167-12461	1246DT	1/2" Dr. x 3/4" x 13/16" Deep Extra Thin Flip
167-12490	1249D	1/2" Dr. x 7/8" x 15/16" Deep Flip

INDIVIDUAL IMPACT SOCKETS

- CR-MO alloy steel for long life
- Radius corner design assists socket in grabbing the flat side of the fastener
- Standard and deep lengths available

Ascot No.	Mfg. No.	Description
METRIC		
163-10111	1011MD	1/2" Dr. x 11mm Deep Impact Socket
163-10131	1013MD	1/2" Drive x 13mm Deep
163-10143	1014MD	1/2" Drive x 14mm Deep
163-10171	1017MD	1/2" Drive x 17mm Deep
163-01018	1018MD	1/2" Drive x 18mm Deep
163-01019	1019MD	1/2" Drive x 19mm Deep
163-01021	1021MD	1/2" Drive x 21mm Deep
163-10222	1022MD	1/2" Drive x 22mm Deep
163-10271	1027MD	1/2" Drive x 27mm Deep
163-10283	1028MD	1/2" Drive x 28mm Deep
163-01032	1032MD	1/2" Drive x 32mm Deep
163-01033	1033MD	1/2" Drive x 33mm Deep
SAE		
163-10161	1016D	1/2" Drive x 1/2" Deep
163-10201	1020D	1/2" Drive x 5/8" Deep
163-01022	1022D	1/2" Drive x 11/16" Deep
163-01024	1024D	1/2" Drive x 3/4" Deep
163-01026	1026D	1/2" Drive x 13/16" Deep
163-10281	1028D	1/2" Drive x 7/8" Deep
163-10300	1030D	1/2" Drive x 15/16" Deep
163-11032	1032D	1/2" Drive x 1" Deep
163-01034	1034D	1/2" Drive x 1-1/16" Deep
163-01036	1036D	1/2" Drive x 1-1/8" Deep
163-10401	1040D	1/2" Drive x 1-1/4" Deep
163-01048	1048D	1/2" Drive x 1-1/2" Deep
163-15260	1526SD	1/2" Drive x 13/16" Square 8-Point

Ascot No.	Mfg. No.	Description
164-02017	2017MS	3/4" Drive x 17mm Square
164-02021	2021MS	3/4" Drive x 21mm Square
164-02024	2024D	3/4" Drive x 3/4" Deep
164-02026	2026S	3/4" Drive x 13/16" Square
164-02030	2030	3/4" Drive x 15/16" Std.
164-02033	2033MD	3/4" Drive x 33mm Deep
164-02034	2034DT	3/4" Drive x 1-1/16" Deep Thin Wall

INDIVIDUAL IMPACT SOCKETS

- CR-MO alloy steel for long life
- Radius corner design assists socket in grabbing the flat side of the fastener
- Standard and deep lengths available

Ascot No.	Mfg. No.	Description
METRIC		
164-20301	2030M	3/4" Drive x 30mm Std.
164-20330	2033M	3/4" Drive x 33mm Std.
SAE		
164-20401	2040D	3/4" Drive x 1-1/4" Deep
164-02038	2038D	3/4" Drive x 1-3/16" Deep
164-02042	2042D	3/4" Drive x 1-5/16" Deep
164-02046	2046D	3/4" Drive x 1-7/16" Deep
164-20480	2048	3/4" Drive x 1-1/2" Std.
164-20481	2048D	3/4" Drive x 1-1/2" Deep
164-02056	2056D	3/4" Drive x 1-3/4" Deep
164-02323	2323C	3/4" Drive x 1-1/2" Hex x 13/16" Square

Ascot No.	Mfg. No.	Description
SAE		
165-03026	3026S	1" Drive x 13/16" Square
165-03030	3030S	1" Drive x 15/16" Square
165-03034	3034DT	1" Drive x 1-1/16" Thin Wall Deep
165-03042	3042D	1" Drive x 1-5/16" Deep
165-03046	3046D	1" Drive x 1-7/16" Deep
165-03052	3052D	1" Drive x 1-5/8" Deep
165-03054	3054D	1" Drive x 1-11/16" Deep
165-03056	3056D	1" Drive x 1-3/4" Deep
165-03060	3060D	1" Drive x 1-7/8" Deep
165-03323	3323C	1" Drive 1-1/2" Hex x 13/16" Square
165-30300	3030	1" Drive x 15/16" Std.
165-30301	3030D	1" Drive x 15/16" Deep
165-30361	3036D	1" Drive x 1-1/8" Deep
165-30362	3036DT	1" Drive x 1-1/8" Deep Thin Wall
165-30380	3038D	1" Drive x 1-3/16" Deep
165-30401	3040D	1" Drive x 1-1/4" Deep
165-30402	3040DT	1" Drive x 1-1/4" Deep Thin Wall
165-30420	3042DT	1" Drive x 1-5/16" Deep Thin Wall
165-30481	3048D	1" Drive x 1-1/2" Deep w/ Inside Lip
165-30482	3048DR	1" Drive x 1-1/2" Deep - Standard

Ascot No.	Mfg. No.	Description
METRIC		
165-03017	3017MS	1" Drive x 17mm Square
165-03019	3019MS	1" Drive x 19mm Square
165-03021	3021MS	1" Drive x 21mm Square
165-30302	3030MD	1" Drive x 30mm Deep
165-03033	3033MD	1" Drive x 33mm Deep
165-03035	3035MD	1" Drive x 35mm Deep
165-30381	3038MD	1" Drive x 38mm Deep
165-30410	3041MDT	1" Drive x 41mm Deep Thin Wall
165-03041	3041MD	1" Drive x 41mm Deep
165-03321	3321MC	1" Drive 41mm x 21mm Square

Ascot No.	Mfg. No.	Description
METRIC		
166-04033	4033MD	#5 Spline x 33mm Deep
166-04035	4035MDT	#5 Spline x 35mm Deep Thin Wall
166-04041	4041MDT	#5 Spline x 41mm Deep Thin Wall
SAE		
166-04026	4026S	#5 Spline x 13/16" Square
166-04034	4034DT	#5 Spline x 1-1/16" Deep Thin Wall
166-04038	4038	#5 Spline x 1-3/16" Std.
166-04040	4040DT	#5 Spline x 1-1/4" Deep Thin Wall
166-04042	4042DT	#5 Spline x 1-5/16" Deep Thin Wall
166-04048	4048D	#5 Spline x 1-1/2" Deep w/Inside Lip
166-40480	4048DT	#5 Spline x 1-1/2" Deep Thin Wall
166-04323	4323C	#5 Spline x 13/16" Square x 1-1/2" Hex

Ascot No.	Mfg. No.	Description
169-01003	1003E	1/2" Drive x 3" Extension
169-01005	1005E	1/2" Drive x 5" Extension
169-01020	1020A	1/2" Drive Female x 3/4" Male Adapt.
169-02006	2006E	3/4" Drive x 6" Extension
169-02010	2010A	3/4" Drive Female x 1/2" Male Adapt.
169-02030	2030A	3/4" Drive Female x 1" Male Adapt.
169-20100	2010E	3/4" Drive x 10" Extension
169-02013	2013E	3/4" Drive x 13" Extension
169-03006	3006E	1" Drive x 6" Extension
169-03010	3010E	1" Drive x 10" Extension
169-03013	3013E	1" Drive x 13" Extension
169-03020	3020A	1" Drive Female x 3/4" Male Adapt.
169-04010	4010A	#5 Spline Female x 3/4" Male Adapt.
169-04020	4020A	#5 Spline Female x 1" Male Adapt.
169-01002	1002E	1/4" Drive x 2" Chrome Extension

TORQUE WRENCHES & TORQUE ACCESSORIES



Heavy Duty Truck Torque Extensions

HEAVY DUTY TRUCK TORQUE EXTENSIONS

- Heavy duty truck extensions can convert sockets into Torque Sockets
- Available in 3/4" and 1" drives

Ascot No.	Mfg. No.	Description
495-16000	LT1600M	3/4" Dr. Truck Torque Extension - 475 ft./lb.
495-16001	LT1600N	3/4" Dr. Truck Torque Extension - 250 ft./lb.
495-16002	LT1600Q	3/4" Dr. Truck Torque Extension - 175 ft./lb.
495-16003	LT1600U	3/4" Dr. Truck Torque Extension - 350 ft./lb.
495-16014	LT1600P	1" Drive Truck Torque Extension - 475 ft./lb.
495-16015	LT1600R	1" Drive Truck Torque Extension - 250 ft./lb.
495-16016	LT1600S	1" Drive Truck Torque Extension - 350 ft./lb.
495-16017	LT1600T	1" Drive Truck Torque Extension - 175 ft./lb.

168-00475
3/4" Drive 33mm
Torque Socket



3/4 DRIVE 33MM TORQUE SOCKET

- Brown Torq stick
- 3/4 in. drive torque socket hex 33mm
- **475 ft/lbs.**
- Solid one-piece construction
- Covered by a **lifetime warranty**

Ascot No.	Mfg. No.	Description
168-00475	334030L7	3/4" Drive 33mm Torque Socket Hex 475ft/lb Brown

169-13413
3/4" x 1" x 13"
Torque Wrench
Extension

168-60020

168-60025



3/4" X 1" X 13" TORQUE WRENCH EXTENSION

Ascot No.	Mfg. No.	Description
169-13413	13413E	3/4" Dr. x 1" Dr. x 13" Impact Extension
168-12997	12297	3/4" Drive Block for Flex Hinge Torque Wrench
168-12999	12299	1" Drive Block for Flex Hinge Torque Wrench

TORQUE FIN TORQUE WRENCH STABILIZER

- **Links with, stabilizes, and properly aligns manual torque wrenches to ensure accurate torque**
- Saves time and money
- Easy to use
- Reduces risk of injury and liability due to wheel-off accidents
- Works with most commercial torque wrenches and truck tires
- Durable and lightweight

Ascot No.	Mfg. No.	Description
168-67250	67250	Torque Fin Torque Wrench Stabilizer



168-67250

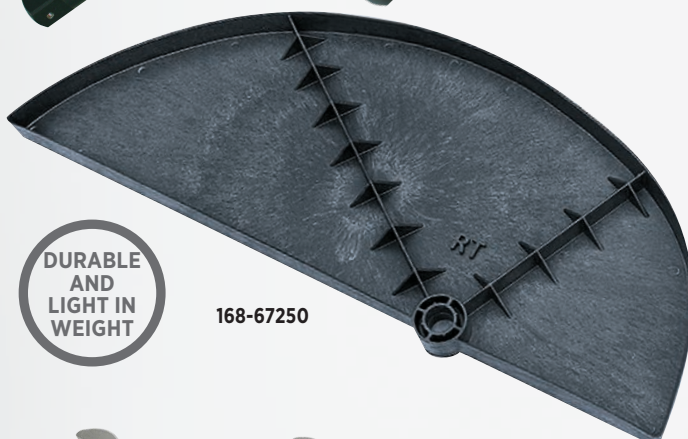

PRESET VALVE NUT TORQUE WRENCHES

- Wrench flexes when proper torque setting is reached
- Prevents overtightening of the valve grommet
- Cushioned handle
- Sizes and preset torque settings laser etched on shaft
- +/- 4% accuracy

Ascot No.	Mfg. No.	Description
168-00058	NSPTW58	5/8" Preset Torque Wrench for TR540-550 Series Valve Hex Nuts
168-00916	NSPTW916	9/16" Preset Torque Wrench for TR570 Series Valve Hex Nuts



168-00058



168-00916

PRECISION INSTRUMENTS

SPLIT-BEAM CLICK TORQUE WRENCHES

- **EXTREMELY ACCURATE:** within 4% of reading from 20% of full scale to full scale
- Setting torque on adjustable wrenches is fast and easy because there is no spring tension on the adjustment knob
- Torque setting locks on adjustable wrenches for repetitive applications

- Wrench length designed to provide the leverage required for maximum torque applications. Also provides the needed reach for those hard to get at places



Ascot No.	Mfg. No.	Description	ft./lb.
168-02100	C2FR100F	3/8" Drive	100
168-03250	C3FR250F	1/2" Drive	250
168-03251	CP3FR250F	1/2" Preset	250
168-04400	C4D600F	3/4" Drive	600
168-05600	C5D600F	1" Drive	600



168-03250



MICROMETER TORQUE WRENCH

- Range is 25 to 250 ft./lb.
- **HEAVY DUTY RATCHET:** Fewer and stronger teeth
- **UNIDIRECTIONAL TORQUEING:** Tightens in right hand direction only, does not tighten in left hand direction for improved performance
- **ERGONOMICALLY DESIGNED HANDLE**
- **MADE FROM MODIFIED SILICONE:** Tear resistant, oil and solvent resistant

- Protective head cover made from modified silicone
- Comes in plastic storage case
- **MADE IN USA**



168-97354



Ascot No.	Mfg. No.	Description
168-97354	97354A	Micrometer Torque Wrench: 25-250 ft./lb.

MICROMETER TORQUE WRENCHES

- Push-through ratchet instead of a reversible ratchet
- Asymmetric design of clicker and ratchet mechanism creates a more robust construction and durable wrench
- Improved lock collar design is easier to grip
- **ACCURACY:** +/- 4% in both directions and improves impact resistance
- **MADE IN USA**



495-97353



Ascot No.	Mfg. No.	Range (Increment)	Drive
495-97353	CEN97353A	30-250 ft./lb.	1/2" push-through drive
495-97355	CEN97355A	100-600 ft./lb.	3/4" push-through drive
495-97362	CEN97362	30-150 ft./lb.	1/2" flex head push-through drive
495-97352	CEN97352A	20-100 ft./lb.	3/8" flex head push-through drive
495-97351	CEN97351A	20-250 in./lb.	3/8" push-through drive
495-97361	CEN97361B	20-200 in./lb.	1/4" push-through drive



TORQUE WRENCHES & TORQUE ACCESSORIES



MICRO-ADJUSTABLE TORQUE WRENCH

- Dual scale, calibrated dual direction
- Positive lock with spring loaded pull down lock ring
- Fast, accurate and easy to set
- Easy-to-read Laser marked scale
- Ergonomic comfort-grip
- Most feature Quick Release buttons

which provide good socket retention as well as easy socket removal

- **RANGE:** 50-250 ft./lb.
- **ACCURACY:** ± 4% clockwise ± 6% CCW of indicated value, CW, from 20% to 100% of full scale

Ascot No.	Mfg. No.	Description
168-12250	2503MFRRH	1/2" Drive Micro-Adjustable Torque Wrench

FLEX HINGE STYLE TORQUE WRENCH

- Robust construction
- ACCURATE RESULTS: +/-4%
- Adjustable torque settings
- DUAL SCALED: ft./lb. and NM
- The large break angle improves accuracy by reducing the possibility of over torquing
- Cam control of the mechanism gives a controlled break
- Every wrench supplied with a calibration certificate
- Durable storage case
- 2 adapters included: 3/4" to 1", 3/4" to 3/4"



168-60012 in case

Ascot No.	Mfg. No.	Description
168-60011	60011	600 ft./lb. Flex Hinge Style Torque Wrench
168-60012	60012	2-Piece 600 ft./lb. Flex Hinge Style Torque Wrench

1" DR. 475 FT/LB PRESET TORQUE WRENCH

- 24 Teeth • Torque Accuracy is +/- 4% • Industrial application with durability Ideal for heavy duty area. • Can be split and packed in two parts for a smaller, easier to transport package • Lockable Blow Molded Case

Ascot No.	Mfg. No.	Description
168-47501	1-475	1" Dr. 475 Ft/Lb Preset Torque Wrench



168-47501 In Case

5-IN-1 INTERCHANGEABLE PRESET TORQUE WRENCH 1/2" DRIVE

- Single direction • Torque preset: 80, 100, 120, 140 to 160 Ft-Lb • Product in matte Finish • Protective cover for the ratcheting head • Angled head attachment • Tolerance of torque ± 4%

Ascot No.	Mfg. No.	Description
168-80246	NS-51PTW	5-In 1 Interchangeable Preset Torque Wrench 1/2" Drive



168-12250 Micro-Adjustable Torque Wrench

168-60011 Flex Hinge Style Torque Wrench



168-60012 2-Pc. 600 ft./lb. Flex Hinge Style Torque Wrench



168-47501 1" Drive Preset Torque Wrench



168-80246 5-In-1 1/2" Drive Preset Torque Wrench



117-58625

FRL UNIT FOR BLUE TORK

- INCLUDES: Industrial grade filter; Regulator; Single point lubricator; 25' hose with capillary tube; 1 Quart of special tool oil approved for the Blue Tork

Ascot No.	Mfg. No.	Description
117-58625	586-254-1000	FRL Unit for Blue Tork

DURABLE AND PORTABLE



168-67505



TORQIT BATTERY-POWERED TORQUE WRENCH

- **Durable and Portable Precision Torque** • Four models from 120 ft./lb. to 3,000 ft./lb. • **LITHIUM ION 8.0 AH RECHARGEABLE BATTERY:** Full charge in under 60 minutes • Every Unit Calibrated In ISO17025 Laboratory • 13-Month Warranty from date of purchase • **MADE IN THE USA**

Ascot No.	Mfg. No.	Description
168-67505	67505	TorqIt Battery-Powered Torque Wrench

1" DRIVE TRUCK TORQUE EXTENSIONS

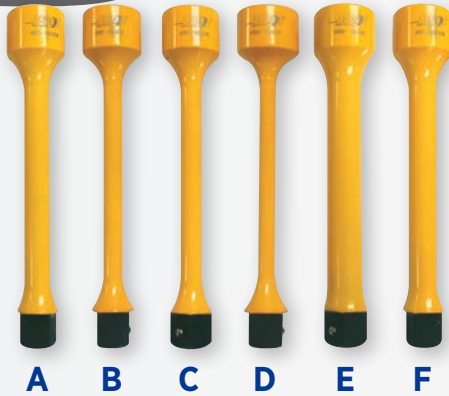

HEAVY DUTY TRUCK TORQUE EXTENSIONS

- Heavy duty truck extensions can convert sockets into Torque Sockets
- Available in 3/4" and 1" drives

Ascot No.	Item	Mfg. No.	Description
495-16004	A	1600-P	1" Drive 475 ft./lbs. Torque Limiting Extension
495-16005	B	1600-R	1" Drive 250 ft./lbs. Torque Limiting Extension
495-16006	C	1600-S	1" Drive 350 ft./lbs. Torque Limiting Extension
495-16007	D	1600-T	1" Drive 175 ft./lbs. Torque Limiting Extension
495-16008	E	1600-W	1" Drive 650 ft./lbs. Torque Limiting Extension
495-16009	F	1600-Y	1" Drive 550 ft./lbs. Torque Limiting Extension

MEDIUM/HEAVY DUTY TORQUE SOCKETS

- **Sockets properly torque wheel nuts to exact factory specs** • Prevents warping of rotors, which causes brake pulsation • Eliminates broken studs and nuts • Avoids damage to aluminum alloy wheels • Stops customer complaints about over-tightened lug nuts • Strobe marks stop turning at the CORRECT torque • Includes heavy duty case

Ascot No.	Mfg. No.	Description
495-30400	KTI30400A	4-Piece Heavy Duty Truck Torque Socket Set. SET INCLUDES: HD Red, HD Brown, HD Black and HD Yellow
495-30940	KTI30940	4-Piece 1" Drive Truck Torque Socket Set. SET INCLUDES: 1-1/4" 1" Drive Torque Hex 250 ft./lb. Red, 33mm 1" Drive Torque Hex 475 ft./lb. Brown, 1-1/2" 1" Drive Torque Hex 475 ft./lb. Black; 13/16" 1" Drive Torque Sq. 475 ft./lb. Yellow

MEDIUM/HEAVY DUTY TORQUE SOCKETS: KIT CONTENTS

Ascot No.	Mfg. No.	Desc.	Drive	Size	Torque	Other
495-30908	KTI30908A	HD Red	1"	1-1/4"	250 ft./lb.	
495-30909	KTI30909A	HD Brown	1"	33mm	475 ft./lb.	
495-30910	KTI30910A	HD Black	1"	1-1/2"	475 ft./lb.	
495-30911	KTI30911A	HD Yellow	1"	13/16"	475 ft./lb.	
495-30913	KTI30913A	HD Grey	1"	33mm	550 ft./lb.	
495-30914	KTI30914A	HD Grey	1"	33mm	550 ft./lb.	Extended
495-30918	KTI30918A	HD Red	3/4"	1-1/4"	250 ft./lb.	
495-30919	KTI30919A	HD Brown	3/4"	33mm	475 ft./lb.	



495-30400

TORQUE WRENCHES & TORQUE ACCESSORIES



168-43237
Norbar Torque Wrench Checker

NORBAR 750 FT./LBS TORQUE WRENCH CHECKER

The 43237 Torque Wrench Checker is an accurate and simple to operate torque wrench checker. There is only one button; used to zero the unit prior to measurement.

- Accurate and Durable
- Easily portable or can be fixed and mounted
- No special skills required to use
- Can be provided with options
- **APPLICATION:** For use with click or break style, or dial torque wrenches

Ascot No.	Mfg. No.	Description
168-43237	43237	Norbar 750 ft./lbs Torque Wrench Checker



168-18141
Pneumatic Torque Multiplier

PNEUMATIC TORQUE MULTIPLIER

- **OPERATING RANGE:** 147 to 738 ft./Lbs. (200 to 1000 Nm)
- 'Soft Start' trigger control aids socket location, and allows gradual and safe reaction location
- Extended reaction is ideal for reaching recessed nuts
- **FAST:** 1000 Nm version has a free speed of 140 rpm for rapid bolt run-down
- **NON IMPACTING:** low vibration levels make these tools comfortable and safe to use
- **QUIET:** less than 85 dB(A) when under load
- For safety, gearbox can rotate independently from the handle so that reaction forces are not transmitted back to the operator
- Light weight for ease of handling
- On Bi-Directional tools, the direction control knob is locked while the tool is running to prevent accidental damage to the gearbox
- Square drive is quickly and easily replaceable

Ascot No.	Mfg. No.	Description
168-18141	PTME-72-2000-B	1" Square Drive Bi-Directional Pneumatic Multiplier



168-42760



INDUSTRIAL TORQUE WRENCH

- **Norbar's New Industrial Torque Wrench** is large and easy to read
- **Split design:** Allows for easy, behind-the-seat storage in service vehicles
- **Smaller carrying case:** Easy to transport, and less expensive to ship back-and-forth for calibration and service
- Removal of calibrated nuts means less expensive to calibrate
- Adjusting scale in the handle
- Calibration is as easy as replacing the paper scale with a new paper scale
- Ratchets are no longer a welded component, making them replaceable when worn or damaged - this means fewer wrenches scrapped
- Operator handle designed to 'guide' the technicians hand into the proper position

Ascot No.	Mfg. No.	Description
168-42760	120110	4AR-N, 3/4" Drive, 150-600 ft./lb. Range
168-42761	120110.01	4AR-N, 1" Drive, 150-600 ft./lb. Range
168-57600	120115	5R-N, 3/4" Drive, 200-750 ft./lb. Range
168-57601	120115.01	5R-N, 1" Drive, 200-750 ft./lb. Range



LOOSE NUT PREVENTION



CHECKPOINT LOOSE LUG NUT INDICATORS*

- A simple and cost-effective solution that helps prevent a catastrophic loss caused by loose lug nuts when used as part of a total torque program
- When fitted on properly torqued lug nuts and inspected by a driver or technician, CHECKPOINT clearly and visually indicate if the wheel nuts have moved
- If the arrows have moved from the point-to-point or daisy-chain pattern, this indicates that they have loosened and need attention
- Facilitates the driver's check for lug nut movement
- Early warning for mechanic or driver of excessive heat caused by possible brake or bearing problems; designed to melt in excessive heat
- Demonstrates fleet's commitment to vehicle road worthiness and safety to the public



The CHECKPOINT Loose Lug Nut Indicators in use.



CHECKPOINT Loose Lug Nut Indicators



CHECKPOINT LOOSE LUT NUT INDICATORS*

- A simple and cost effective product that can help guard against a potential catastrophic loss caused by loose lug nuts when used as part of a total torque wheel program
- When fitted on properly torqued lug nuts and inspected by a driver or technician, the CHECKPOINTS clearly and visually indicate if the lug nuts have moved
- If the arrows have moved from the point-to-point pattern, this indicates that they have loosened and need attention
- Enhanced fleet safety management
- Facilitates the driver's check for lug nut movement and involvement with vehicle safety
- Early warning for mechanic or driver of excessive heat caused by possible brake or bearing problems
- Demonstrate your fleet commitment to vehicle road worthiness and safety
- **QUANTITY:** 100 per bag



402-20021

402-20033

402-20333

Ascot No.	Mfg. No.	Description
CHECKPOINT		
402-20017	CPY17MM	CHECKPOINT 17mm Fluorescent Yellow Loose Lug Nut Indicator
402-20018	CPY18MM	CHECKPOINT 18mm Fluorescent Yellow Loose Lug Nut Indicator
402-20019	CPY19MM	CHECKPOINT 19mm Fluorescent Yellow Loose Lug Nut Indicator
402-20020	CPY20MM	CHECKPOINT 20mm Fluorescent Yellow Loose Lug Nut Indicator
402-20021	CPY21MM	CHECKPOINT 21mm Fluorescent Yellow Loose Lug Nut Indicator
402-20078	CPY22MM	CHECKPOINT 22mm (7/8") Fluorescent Yellow Loose Lug Nut Indicator
402-20023	CPY23MM	CHECKPOINT 23mm Fluorescent Yellow Loose Lug Nut Indicator
402-20024	CPY24MM	CHECKPOINT 24mm Fluorescent Yellow Loose Lug Nut Indicator
402-20001	CPY25MM	CHECKPOINT 25mm (1") Fluorescent Yellow Loose Lug Nut Indicator
402-20026	CPY26MM	CHECKPOINT 26mm Fluorescent Yellow Loose Lug Nut Indicator
402-20027	CPY27MM	CHECKPOINT 27mm Fluorescent Yellow Loose Lug Nut Indicator
402-20028	CPY28MM	CHECKPOINT 28mm Fluorescent Yellow Loose Lug Nut Indicator
402-20029	CPY29MM	CHECKPOINT 29mm Fluorescent Yellow Loose Lug Nut Indicator
402-20030	CPY30MM	CHECKPOINT 30mm Fluorescent Yellow Loose Lug Nut Indicator
402-20114	CPY31MM	CHECKPOINT 31mm (1-1/4") Fluorescent Yellow Loose Lug Nut Indicator
402-20032	CPY32MM	CHECKPOINT 32mm Fluorescent Yellow Loose Lug Nut Indicator
402-20033	CPY33MM	CHECKPOINT 33mm Fluorescent Yellow Loose Lug Nut Indicator
402-20034	CPY34MM	CHECKPOINT 34mm Fluorescent Yellow Loose Lug Nut Indicator
402-20035	CPY35MM	CHECKPOINT 35mm Fluorescent Yellow Loose Lug Nut Indicator
402-20036	CPY36MM	CHECKPOINT 36mm Fluorescent Yellow Loose Lug Nut Indicator
402-20015	CPY38MM	CHECKPOINT 38mm (1-1/2") Fluorescent Yellow Loose Lug Nut Indicator
402-20040	CPY40MM	CHECKPOINT 40mm Fluorescent Yellow Loose Lug Nut Indicator
402-20041	CPY41MM	CHECKPOINT 41mm Fluorescent Yellow Loose Lug Nut Indicator
402-20044	CPY44MM	CHECKPOINT 44mm Fluorescent Yellow Loose Lug Nut Indicator
402-20046	CPY46MM	CHECKPOINT 46mm Fluorescent Yellow Loose Lug Nut Indicator

Ascot No.	Mfg. No.	Description
402-20021	CPY21MM	CHECKPOINT 21mm Fluorescent Yellow Loose Lug Nut Indicators
402-20033	CPY33MM	CHECKPOINT 33mm Fluorescent Yellow Loose Lug Nut Indicator
402-20333	CPTR33MM	CHECKTORQUE 33mm Red Loose Lug Nut Indicator (Re-torque after first 100 Miles)

*The use of CHECKPOINT Loose Lug Nut Indicators does not guarantee wheel-offs will not occur.

LOOSE NUT PREVENTION



Ascot No.	Mfg. No.	Description
CHECKPOINT HI-TEMP		
402-21019	CPOHY19MM	CHECKPOINT 19mm Orange Hi-Temp Loose Lug Nut Indicator
402-21021	CPOHY21MM	CHECKPOINT 21mm Orange Hi-Temp Loose Lug Nut Indicator
402-21022	CPOHY22MM	CHECKPOINT 22mm Orange Hi-Temp Loose Lug Nut Indicator
402-21030	CPOHY30MM	CHECKPOINT 30mm Orange Hi-Temp Loose Lug Nut Indicator
402-21031	CPOHY31MM	CHECKPOINT 31mm Orange Hi-Temp Loose Lug Nut Indicator
402-21032	CPOHY32MM	CHECKPOINT 32mm Orange Hi-Temp Loose Lug Nut Indicator
402-21033	CPOHY33MM	CHECKPOINT 33mm Orange Hi-Temp Loose Lug Nut Indicator
402-21036	CPOHY36MM	CHECKPOINT 36mm Orange Hi-Temp Loose Lug Nut Indicator
402-21038	CPOHY38MM	CHECKPOINT 38mm Orange Hi-Temp Loose Lug Nut Indicator
402-21040	CPOHY40MM	CHECKPOINT 40mm Orange Hi-Temp Loose Lug Nut Indicator
402-21041	CPOHY41MM	CHECKPOINT 41mm Orange Hi-Temp Loose Lug Nut Indicator
402-21044	CPOHY44MM	CHECKPOINT 44mm Orange Hi-Temp Loose Lug Nut Indicator
402-21046	CPOHY46MM	CHECKPOINT 46mm Orange Hi-Temp Loose Lug Nut Indicator
POINT TO POINT		
402-20133	CPCYPP33MM	CHECKPOINT Caution Yellow Point to Point 33MM Loose Lug Nut Indicator
402-20333	CPTRPP33MM	CHECKTORQUE Point to Point 33MM Red Loose Lug Nut Indicator



TIRE EQUIPMENT MANUFACTURER

Ascot No.	Mfg. No.	Description
402-23133	CPOHTPP33MM	Checkpoint Point to Point 33MM Orange Hi-Temp Loose Lug Nut Indicator
DUSTITE		
402-24027	CPDTY27MM	Dustite Yellow 27mm Loose Lug Nut Indicator
402-24028	CPDTY28MM	Dustite Yellow 28mm Loose Lug Nut Indicator
402-24030	CPDTY30MM	Dustite Yellow 30mm Loose Lug Nut Indicator
402-24032	CPDTY32MM	Dustite Yellow 32mm Loose Lug Nut Indicator
402-24033	CPDTY33MM	Dustite Yellow 33mm Loose Lug Nut Indicator
402-24038	CPDTY38MM	Dustite Yellow 38mm Loose Lug Nut Indicator
402-24133	CPDTSG33MM	Dustite Silver Gray 33mm Loose Lug Nut Indicator
DUSTITE LONG REACH		
402-25032	CPDRLRY32MM	Dustite Long Reach Yellow 32mm Loose Lug Nut Indicator
402-25033	CPDRLRY33MM	Dustite Long Reach Yellow 33mm Loose Lug Nut Indicator
402-25133	CPDRLRSG33MM	Dustite Long Reach Silver Gray 33mm Loose Lug Nut Indicator
402-25021	CPDRLRY21MM	Dustite Long Reach Yellow 21mm Loose Lug Nut Indicator
402-25022	CPDRLRY22MM	Dustite Long Reach Yellow 22mm Loose Lug Nut Indicator

**The use of CHECKPOINT Loose Lug Nut Indicators does not guarantee wheel-offs will not occur.*

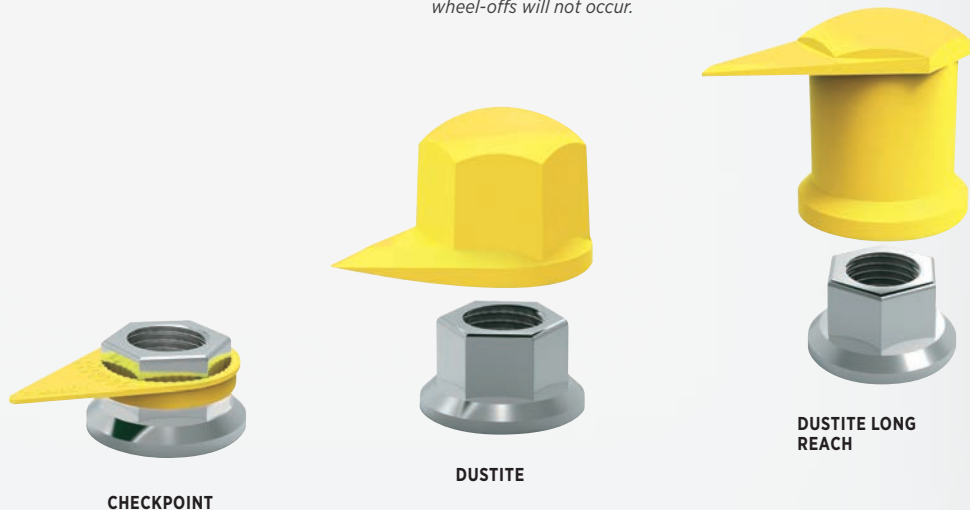



HEXCHEX MULTI-SIZE LOOSE WHEEL NUT INDICATOR

- **7 SKUs work for 31 different nut sizes!** • Easier to store on the shelves and to find the correct part for the customer • Designed not to melt under heavy braking situations but will melt if the hub overheats which will alert driver of hub problems • If HexChex melts, the non stick material is removed easily without damaging your wheels or lug nuts • Easy to use and no tools are needed for the application • Fits around any shaped nut including 8 or 10 sided custom nuts • HexChex are made of durable polymer and are chemical resistant

Ascot No.	Mfg. No.	Description
402-30601	KT #30601	Metric: 19mm - 23mm SAE 3/4" - 1"
402-30602	KT #30602	Metric: 23mm - 30mm SAE 1" - 1 3/16"
402-30603	KT #30603	Metric: 30mm - 38mm SAE 1 3/16" - 1 1/2"
402-30604	KT #30604	Metric: 38mm - 50mm SAE 1 1/2" - 2"
402-30607	KT #30603R (Red)	Metric: 30mm - 38mm SAE: 1-3/16" to 1-1/2"
402-30608	KT #30603G (Green)	Metric: 30mm - 38mm SAE: 1-3/16" to 1-1/2"
402-30609	KT #30603B (Black)	Metric: 30mm - 38mm SAE: 1-3/16" to 1-1/2"



402-30601

ONLY 7 SKUS FOR 31 SIZES

CHEMICAL RESISTANT

ROLLOCK - LOOSE NUT PREVENTION

- **Cost effective way to prevent wheel nuts from loosening** • Galvanized steel product locks wheel nuts in place • **APPLICATION:** ROLLOCK is for use on 19.5 & 22.5 Hub-Piloted Wheels (8 or 10 hole) • **ROLLOCK IS EASY TO REMOVE:** Unscrew the Wheel Nut in normal manner and the ROLLOCK clamp will easily come off



The Rollock is a cost effective way to prevent nuts from loosening.



402-62000

LOCKS WHEEL NUTS IN PLACE

COST EFFECTIVE

Ascot No.	Mfg. No.	Description
402-62000	62000	Rollock, 4-1/8" Spacing, 30-33mm Nut
402-62500	62500	Rollock, 3-1/2" Spacing, 30-33mm Nut

LUG LOCK WHEEL NUT RETAINERS

- **Use the resistance between two nuts to minimize their ability to rotate and loosen** • Flexible and easy to install, fits over two adjacent nuts • Field tested at high and low rotation levels • Lab tested in severe vibration conditions • **APPLICATION:** Designed to be used on wheels with 33mm nuts on 3.5" stud centers • Compatible with a complete wheel mounting safety program • *Other sizes and colors available*

FIELD TESTED

FLEXIBLE & EASY TO INSTALL



402-62600

Other sizes and colors available.



The Lug Lock Wheel Nut Retainers in use.

Ascot No.	Mfg. No.	Description
402-62600	62600	3 1/2" Spacing, 350 degrees

WHEEL CENTERING PRODUCTS



COUNTERACT WHEEL CENTERING SLEEVES

• Patent pending wheel centering system that works in conjunction with your OEM style two-piece flange nuts • Unique self-sizing & non-corrosive design is made to take-up the gap between the 22mm stud and the 26mm wheel opening, re-aligning the wheel to the TRUE CENTER of the hub bearing • **BENEFITS INCLUDE:** Increased fuel mileage, increased tire life, decreased tire vibration, stops irregular tire wear, decreased tire maintenance, reduced tire cupping, reduced “wheel off” conditions • Specifically designed to ensure your wheel is centered on the wheel assembly • Made from a high temperature resistant polyamide



The Counteract Wheel Centering Sleeves in use.



491-02006

Ascot No.	Mfg. No.	Description
491-02006	WCS-B	Counteract Wheel Centering Sleeves (Pack of 6)
491-02100	WCS-C	Counteract Wheel Centering Sleeves (Bucket of 100)
491-02101	WCS-D	Counteract Wheel Centering Sleeves (Bucket of 1000 w/ Installation Tool)

COUNTERACT INSTALLATION/REMOVAL TOOL

• Specifically designed to install and remove Counteract Centering Sleeves

Ascot No.	Mfg. No.	Description
491-02111	WCS-IT	Counteract Installation/Removal Tool



491-02100



491-02111

“EZ ON” WHEEL & BRAKE DRUM CENTERING SLEEVES

• These sets center both steer axle HD wheels and brake drums to minimize wheel vibrations, brake pedal pulsations and wheel hop • **APPLICATION:** For both Aluminum and Steel steer wheels and a variety of brake drum types

Ascot No.	Mfg. No.	Description
491-32120	32120	Aluminum 1.25" hole/.5" depth
491-32121	32121	Aluminium 1.25" hole/.25" to .3125" depth
491-32124	32124	Steel 1.25" hole/.5" depth



491-32121

491-32120

491-32124

O-LINE-ER WHEEL STUD ALIGNMENT TOOL

- Makes it easy to line up wheel studs with holes in rim for easy installation
- Decreased installation time
- Increase worker productivity
- Reduce risk of injury from struggling with heavy tires and rims



491-00101

The O-Line-Er Wheel Stud Alignment Tool makes it easy to line up wheel studs with holes in rim for easy installation.

Ascot No.	Mfg. No.	Description
491-00101	GTO-01TB	O-Line-Er Wheel Stud Alignment Tool

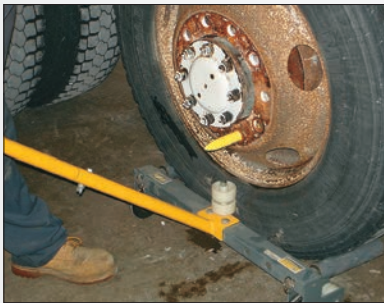

“SOLUTION B” INTERNAL CENTERING SLEEVES

- Threaded Inside for best positioning and retention
- Stays on wheels
- Zinc plated to resist corrosion
- All brake drum numbers are subject to change without warning due to manufacturer changes beyond our control
- Sold in sets of 6 per axle

“SOLUTION A” WHEEL CENTERING PIN SETS

- Reusable Shop Tool
- Hardened Steel
- Threaded Inside for Easy Removal
- Sold in sets of 3 with storage case

Ascot No.	Mfg. No.	Description	Gunite #		
491-01504	B-1504-GA	1.25" diameter hole, 1/2" hole depth	3573X	3687X	3758X
			3596X	3710X	3774X
			3597X	3786X	3800X
			3598X	3721AX	
			3686X	3726X	



Ascot No.	Mfg. No.	Description
491-02666	A-2666	Steer & Drive axles, 5" length, Steel & Aluminum wheels, will center 1" brake drums
491-01573	A-1573	Steer & Drive axles and some trailers, 4" length, Steel & Aluminum Wheels
491-01339	A-1339	Steer axles, 3" length, Steel & Aluminum wheels

Ascot No.	Mfg. No.	Description	Conmet #		
491-01825	B-1825-CON-A	1.34 - 1.37" diameter hole, 1/2" hole depth	107507	1001783	10005331
			10033071	10005332	10037815
			10009920		

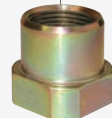

Ascot No.	Mfg. No.	Description	Conmet #		WEBB #	
491-01860	B-1860-CON-A	1.28" diameter hole, 1/2" hole depth	107164	10001780	65161B	65548B
			107193	10001781	65167B	65554B
			107453	10001783	61528B	65710B
			107862		65547B	



Ascot No.	Mfg. No.	Description	Gunite #	Motor Wheel Centrifuse #	Arvin Meritor #
491-01594	B-1594-CA	1.25" Diameter Hole, 1/4" Hole Depth	9001X	90089BK	53-123512-002
			9000X	89870BK	53-123542-002
			9035X	90174BK	53-123627-002
				91265B	53-123-589-002
				90600B	53-123-608-002
				90137B	



491-02666

491-01573

491-01339



LUG NUT REMOVAL PRODUCTS



NUT BUDDY LUG NUT REMOVER

- It loosens the most stubborn wheel nuts • APPLICATION: Use on commercial or agricultural wheels • GEAR RATIO: 58:1
- RATED OUTPUT TORQUE: 2950 ft/lbs. • TWO SOCKETS INCLUDED: 1-1/2" (38mm) and 1-5/16" (33mm)

LOOSENS STUBBORN



404-67300

Ascot No.	Mfg. No.	Description
404-67300	67300	Nut Buddy Lug Nut Remover



PORTABLE TRUCK WHEEL STUD REMOVER & INSTALLER

- Power of a 10-ton shop press
- Remove and install studs without removing the hub
- Two-hour job is done in twenty minutes without risk of damaging seals or bearings
- Any mechanic can use it to get the job done right in minutes



POWER OF A 10-TON SHOP PRESS

QUICK AND EASY TO USE

492-06346

Ascot No.	Mfg. No.	Description
492-06247	6247	PakPress Cart
492-06346	6346	Complete PakPress Kit - Includes Cart

9-PIECE SAVE-A-STUD RETHREAD KIT

- Repairs damaged wheel studs
- 9-Piece Rethread Kit
- For passenger, light truck, and heavy duty
- Guaranteed for life
- Individual dies available

LIFETIME GUARANTEE



493-31210

KIT CONTENTS

SAE: 7/16"-20, 1/2"-20, 9/16"-18, 5/8"-18
METRIC: 12mm-1.25, 12mm-1.50, 12mm-1.75, 14mm-1.50, 14mm-2.00

Ascot No.	Mfg. No.	Description
493-31210	31210	9-Piece Save-A-Stud Rethread Kit



SAV-A-STUD RETHREAD KIT - TRUCK

- Repairs wheel studs, spindles and standard threaded studs
- Lifetime warranty



493-30125

Ascot No.	Mfg. No.	Description
493-30120	30120	Save-A-Stud Plus Rethread Kit (9 pcs.) - INCLUDES: 9/16" - 18, 5/8" - 18, 14mm - 1.5, 14mm - 2.0, 7/16" x 20, 1/2" - 20 Right, 12mm - 1.25, 12mm - 1.5, 12mm - 1.75
493-30125	30125	Save-A-Stud Plus HD (3 pcs.) - INCLUDES: 3/4" - 16" Right, 3/4" - 16" Left, 22 - 1.5mm

COMMERCIAL TRUCK CHROME LUG NUT PULLER

- Thick carbon steel material provides strength for heavy duty applications
- Round shape handle provides comfort and ease of operation
- Suitable for all heavy duty truck lug nut applications
- Two hole design can be switched to expand range and size of application
- Coated jaws protect painted, aluminum or chrome plated lug nuts from damage



402-03116
Commercial Truck Chrome Lug Nut Puller

Ascot No.	Mfg. No.	Description
402-03116	202603-HD	Commercial Truck Chrome Lug Nut Puller

HEAVY DUTY PROFESSIONAL CHROME NUT PULLER

- Coated to prevent scratching or damage to chrome, coated or painted lug covers
- Cushioned grip to prevent slippage
- **NO ADJUSTMENT REQUIRED:** Fits all 33mm & 1½" covers
- **Similar to Ken Tool 30606**



402-03016
Heavy Duty Professional Chrome Nut Puller

Ascot No.	Mfg. No.	Description
402-03016	202603	Heavy Duty Professional Chrome Nut Puller with Cushion Handle

CHROME LUG NUT COVER REMOVER

- Coated to prevent scratching or damage to chrome, coated or painted lug covers
- Cushioned grip to prevent slippage



402-30606
Chrome Lug Nut Cover Remover

Ascot No.	Mfg. No.	Description
402-30606	30606	Chrome Lug Nut Cover Remover

4-PIECE LUG NUT REMOVER IMPACT SOCKET SET

- APPLICATION: Use for removing wheel locks or damaged lug nuts • Patented, internal tapered reverse threads lock onto damaged nut and easily pulls off using impact wrench • Convenient compact storage case • INCLUDES THE FOLLOWING 1/2" DRIVE SIZES: 3/4", 13/16", 1", 1-1/8" • **MADE IN USA**

Ascot No.	Mfg. No.	Description
492-30254	30254	4-Piece Lug Nut Remover Impact Socket Set INCLUDES: 3/4", 13/16", 1", 1-1/8" (1/2" Drive)



492-30254

492-30649

4-PIECE HEAVY DUTY WHEEL STUD REMOVER SET

- APPLICATION: Removes damaged wheel studs and inner Budd nuts
- Patented, internal tapered reverse threads lock onto damaged stud or nut and easily pulls off using impact wrench • Wheel Stud Removers are 3/4" hex drive • Budd Nut Removers are 1-1/8" hex drive • Convenient compact storage case, 6.5" x 4.5" x 2.75"; 3.5 lbs • SET INCLUDES THE FOLLOWING SIZES: 5/8", 3/4", 1-1/8" Budd wheel inner nut left hand thread, 1-1/8" Budd wheel inner nut right hand thread • **MADE IN USA**

Ascot No.	Mfg. No.	Description
492-30649	30649	4-Piece Heavy Duty Wheel Stud Remover Set INCLUDES: 5/8", 3/4", 1-1/8" Budd left hand, 1-1/8" Budd right hand

WHEEL ATTACHING HARDWARE



GRADE 8 DISC WHEEL HARDWARE-INNER CAP NUTS

Ascot No. for Sirco	Sirco No.	Ascot No. for GLP	GLP No.	Outer Thread	Inner Thread	Overall Length	Similar To:			
491-00708	708AR	491-01001 (RH)	GL-1001	1 1/8" - 16	3/4" - 16	2 7/32"	Budd 10708	Euclid 7895R	Leland W-11	Steel/Steel
491-00709	709AL	491-01002 (LH)	GL-1002	1 1/8" - 16	3/4" - 16	2 7/32"	Budd 10709	Euclid 7895L	Leland W-12	Steel/Steel
491-00896	896R	491-01003 (RH)	GL-1003	1 1/8" - 16	3/4" - 16	2 9/16"	Budd 35336	Euclid 7896R	Leland W-620	Steel/Alum
491-01896	896L	491-01004 (LH)	GL-1004	1 1/8" - 16	3/4" - 16	2 9/16"	Budd 35337	Euclid 7896L	Leland W-621	Steel/Alum
491-00897	897R	491-01005 (RH)	GL-1005	1 1/8" - 16	3/4" - 16	3 1/16"	Budd 22621	Euclid 7897R	Leland W-616	Steel/Alum
491-01897	897L	491-01006 (LH)	GL-1006	1 1/8" - 16	3/4" - 16	3 1/16"	Budd 22622	Euclid 7897L	Leland W-617	Steel/Alum
491-00978	988R	491-01011 (RH)	GL-1011	1 1/8" - 16	3/4" - 16	3 1/16"	Alcoa 5988R	Euclid 5988R	Leland W-486	Alum/Alum
491-01978	988L	491-01012 (LH)	GL-1012	1 1/8" - 16	3/4" - 16	3 1/16"	Alcoa 5988L	Euclid 5988L	Leland W-487	Alum/Alum
METRIC										
491-00306	306R	491-01009 (RH)	GL-1009	M30 -1.5	M20 -1.5	M-62 (2 7/16")	Hino 900423101	Isuzu 1-42335005 - Zinc		
491-01306	306L	491-01010 (LH)	GL-1010	M30 -1.5	M20 -1.5	M-62 (2 7/16")	Hino 900424101	Isuzu 1-42336005 - Zinc		



491-01001



491-01003



491-01011



Lubricate nut & stud before applying to the vehicle

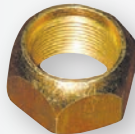

491-02001



491-02203



491-00600
Installation Tool for Alcoa Hub Cover Systems

GRADE 8 DISC WHEEL HARDWARE-OUTER CAP NUTS

Ascot No. for Sirco	Sirco No.	Ascot No. for Haltec	Haltec No.	Similar To:		
491-00891	891AR	491-02001 (RH)	GL-2001	Budd 37891	Euclid 5997R	Leland W-13
491-00892	892AL	491-02002 (LH)	GL-2002	Budd 37892	Euclid 5997L	Leland W-14
491-00888	888R	491-02101 (RH)	GL-2101	Budd 37888	Euclid 5652R	Leland W-15
491-00889	889L	491-02102 (LH)	GL-2102	Budd 37889	Euclid 5652L	Leland W-16
491-00995	995R	491-02103 (RH)	GL-2103	Alcoa 5995R	Euclid 5995R	Leland W-506
491-01995	995L	491-02104 (LH)	GL-2104	Alcoa 5995L	Euclid 5995L	Leland W-507
N/A	891BR	491-01891	GL-2004	THRU HARDNESS - GMC-3988631		
N/A	892BL	491-02892	GL-2003			
N/A	N/A	491-02203	GL-2203	Budd 95188	Euclid 9022R	Dodge 3637719
N/A	N/A	491-02204	GL-2204	Budd 95189	Euclid 9022L	Dodge 3637720
N/A	N/A	491-02202	GL-2202	Budd 81269	Euclid 5734	GMC 3771410
N/A	N/A	491-02303	GL-2303	Alcoa 389928	Ford E4tZ-1012A	N/A
METRIC						
491-00304	304R	491-02009	GL-2009	Hino 900421112	Isuzu 1-42333023	Leland W-722/3
491-01304	304L	491-02010	GL-2010	Hino 900422104	Isuzu 1-42334023	Euclid 10254R/L
491-00033	333B	491-02301	GL-2301	Budd 106333	Euclid 6000A	Leland W-498
491-00881	881M	491-02302	GL-2302	MW 88881	Euclid 5991	Leland W-492

INSTALLATION TOOL FOR ALCOA HUB COVER SYSTEMS

• **APPLICATION:** For use with Alcoa 076185, 077185, 076188 & 077188 Hub Systems

Ascot No.	Mfg. No.	Description
491-00600	600	Installation Tool for Alcoa Hub Cover Systems

MUD FLAP BOLT KIT

• All the hardware needed to attach mud flaps to trucks or trailers • **INCLUDES:** (4) 3/8"-16 x 1-1/4" bolts, (4) 3/8" Nuts, (8) 3/8" flat washers & (4) 3/8" lock washers



491-00038
Mud Flap Bolt Kit

Ascot No.	Mfg. No.	Description
491-00038	MFBK	Mud Flap Bolt Kit

SPOKE WHEEL HARDWARE



491-03005



491-03002

Ascot No. for Sirco	Sirco No.	Ascot No. for GLP	GLP No.	Thread	Similar To:
RIM CLAMP NUTS					
491-00149	149	491-03004	GL-3004	5/8-11	Dayton 5149 Euclid 4962 Leland W-7
491-00716	716	491-03005	GL-3005	3/4-10	Dayton 5716 Euclid 4963 Leland W-8
RIM STUDS (GRADE 8)					
491-00654	654	491-03001	GL-3001	5/8-11x2-3/4	Dayton 6654 Euclid 4958 Leland W-5
N/A	N/A	491-03002	GL-3002	3/4-10x3	Dayton 5715 Euclid 4956-A Leland W-6

LOCKING BACK NUTS



491-06023

Ascot No.	Mfg. No.	Size	Similar To:
491-06023	GL-6023	5/8"-18	MW 85643 —
491-02431	GL-2431	7/8"-14	Budd 41073-8 Euclid 1835
491-02445	GL-2445	1"-14	Budd 44672-9 Euclid 1828

OIL SEAL HUBCAPS AND GASKETS

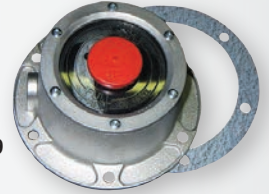

491-04009

Ascot No.	Mfg. No.	Description
491-04009	GL-4009	Standard 6-Hole Hubcap
491-04012	GL-4012	6-Hole Gasket for Above
491-04013	GL-4013	Universal Gasket - 5 or 6 Hole
491-04020	GL-4020	Replaceable Window Kit
491-04021	GL-4021	Rubber Plug for Bolt-On Cap
491-09013	GL-4913	Fruehauf/Propar Cap
491-09014	GL-4974	O-Ring for Screw-On Cap
491-09015	GL-4975	Rubber Plug for Screw-On Cap

CONE WHEEL NUTS



491-00014

Ascot No.	Mfg. No.	Size	Description
491-00014	GL-0014	7/16"-20 (3/4" Hex, 9/16" High)	G.M.
491-00016	GL-0016	1/2"-20 (13/16" Hex, 5/8" High)	Ford
491-00027	GL-0027	1/2"-20 (3/4" Hex, 9/16" High)	Chrysler
491-00062	GL-0062	12mm-1.5 (19mm Hex, 14mm High)	G.M.
491-00066	GL-0066	12mm-1.5 (21mm Hex, 16mm High)	Toyota
491-00065	GL-0065	12mm-1.25 (21mm Hex, 16mm High)	Nissan
491-00064	GL-0064	12mm-1.25 (19mm Hex, 16mm High)	Nissan
491-00052	GL-0052	9/16"-18 (7/8" Hex, 3/4" High)	G.M.
491-00055	GL-0055	R.H. 5/8"-18 (1" Hex, 21/32" High)	Budd 67147
491-00056	GL-0056	L.H. 5/8"-18 (1" Hex, 21/32" High)	Budd 67147

BRAKE DRUM MOUNTING HARDWARE



491-06014

Ascot No.	Mfg. No.	Size	Description
491-06012	GL-6012	5/8-18 x 2"	5/8" Brake Bolt/Washer/Assembly
491-06014	GL-6014	3/4-16 x 2"	3/4" Brake Bolt/Washer/Assembly
491-06020	GL-6020	5/8-18 x 2"	Brake Bolt Only
491-06021	GL-6021	3/4-16 x 2"	Brake Bolt Only
491-06025	GL-6025	5/8"	Flat Washer
491-06026	GL-6026	3/4"	Flat Washer
491-06023	GL-6023	5/8"-18"	Lock Nut Only
491-06024	GL-6024	3/4"-16"	Lock Nut Only

WHEEL ATTACHING HARDWARE



RIM CLAMPS



491-03097



491-03113

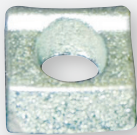

491-06115

Ascot No. for Sirco	Sirco No.	Ascot No. for GLP	GLP No.	A Dim.	B Dim.	C Dim.	Similar To:		
491-00399	399	491-03083	GL-3083	N/A	N/A	N/A	Dayton 8399	Euclid 5927	Leland W-124
491-00729	729	491-03087	GL-3087	N/A	N/A	N/A	Dayton 09-729514	Euclid 5838	Leland W-407
491-00123	123	491-03096	GL-3096	1-1/8"	2-7/8"	2-11/32", 3/4" Stud	Dayton 6123	Euclid 5571A	Leland W-3
491-00235	235	491-03097	GL-3097	1-3/4"	2-7/8"	2-11/32", 3/4" Stud	Dayton 6235	Euclid 5572A	Leland W-4
491-00993	993	491-03098	GL-3098	1-1/2"	2-7/8"	2-11/32", 3/4" Stud	Dayton 6993	Euclid 5040A	Leland w-120
N/A	N/A	491-03099	GL-3099	2-1/8"	2-7/8"	2-11/32", 3/4" Stud	Dayton 705317	Euclid 5786	Leland W-403
N/A	N/A	491-03101	GL-3101	1-7/8"	2-7/8"	2-11/32", 3/4" Stud	Dayton 851817	Webb 16124	Leland W-404
N/A	N/A	491-03103	GL-3103	1-1/4"	2-7/8"	2-11/32", 3/4" Stud	Dayton 8708	Euclid 5784	Leland W-405
491-00053	053	491-03104	GL-3104	2"	2-7/8"	2-11/32", 3/4" Stud	Dayton 870917	Euclid 5785	Leland W-406B
Ascot No. for Sirco	Sirco No.	Ascot No. for GLP	GLP No.	Similar To:					
491-00257	257	491-03113	GL-3113	Mack 15QJ-17P1		Euclid 5828	Leland W-450		
491-00238	238	491-03271	GL-3271	Mack 15QJ-223BP8		Euclid 5781	Leland W-448		
491-00233	233	491-03279	GL-3279	Mack 15QJ-223BP3		Euclid 5821	Leland W-467		
N/A	N/A	491-06115	GL-6115	Kelsey 79954		N/A	N/A		



STANDARD WHEEL RIM GUARD

- **APPLICATION:** Protects aluminum, chrome and painted truck rims/wheels during stud and nut removal
- Inexpensive
- Tough polymer design

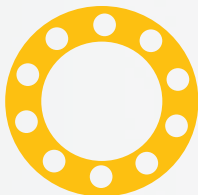

402-50301

Ascot No.	Mfg. No.	Description
402-50301	50301	Standard Wheel Rim Guard



The standard wheel rim guard in use.

DISCMATE WHEEL PROTECTORS

- Used to protect the wheel's mounting surface from cosmetic damage during use
- Placed between the wheel and it's mounting surface on the vehicle and may also be used between 2 dualed wheels for added protection
- Wheel nuts should always be tightened to the correct torque following the wheel manufacturer's specifications



Discmate Wheel Protectors

Ascot No.	Mfg. No.	Description
402-11000	61020	10-Hole 285.75mm, Hub Pilot, 22mm Studs
402-17000	61000	10-Hole 11-1/4" Stud-Pilot, 1-1/8" Studs
402-18000	61040	10-Hole 335mm, 32mm Cap Nuts, 22mm Studs



SKIRT NUTS

- Stops wheel/hub vibrations and many tire wearing problems
- Stops wheel movement (clocking) on the face of the hub
- Eliminates wasted fuel caused by rolling resistance or “drag”
- Meets and exceeds standards of SAE J1965 for torque tension
- Replaces all style M22 flange nuts on hub-piloted wheel
- **HEX:** 33mm
- Special graphite coating prevents nut from rusting onto the hub
- Fills in the gap between the stud and the bolt 3/16” (5mm)
- **QUANTITY:** 25 per box

Ascot No.	Mfg. No.	Description
491-02301	GL-2301	Haltec 33mm 2-Piece Flange Nut: • 130 per Case • Inner Thread M22-1.5 • For Uni-Mount 10-Hole Systems
491-02906	GL-2906	Haltec 6mm Sleeve Nut: Steel Steers
491-02919	GL-2919	Haltec 19mm Sleeve Nut: • Aluminum Steers • Steel/Steel Drives • Steel Outer/Aluminum Inner Drives
491-02928	GL-2928	Haltec 28mm Sleeve Nut: • HD Aluminum • Super Single • Wide Base • Aluminum Outer/Steel Inner Drives
491-02939	GL-2939	Haltec 39mm Sleeve Nut: Dual Aluminum Drive Axle



491-02906
6mm Sleeve



491-02928
28mm Sleeve



491-02301
33mm
2-Piece
Flange Nut



491-02919
19mm Sleeve



491-02939
39mm Sleeve



Extended threading allowing Skirt Nut to go down into Hub-Piloted Disc Wheel an extra 3/16” (5mm) into stud hole



There is a fairly large tolerance between the diameter of each stud hole and the diameter of the stud itself.



WHEEL ATTACHING HARDWARE



33MM SKIRT NUT

- Original Skirt Nut • Replaces standard M22 flange nuts on 11.25" hub-piloted wheels
- Partially penetrates the stud hole and prevents clocking and vibration
- Quantity: 100 per case



491-01133

Ascot No.	Mfg. No.	Description
491-01133	SN-M22	33mm Skirt Nut

HUB CENTRIC NUT

By filling the void between the stud hole, "clocking" is eliminated, and problems caused by clocking, such as wheel offs and wheel hub vibrations, are eliminated.

- **Hub Centric Nut fills void standard flange nuts don't**
- **Stops rim from shifting** forwards or backwards
- **Eliminates "clocking"** caused by standard wheel nuts not filling wheel hole completely
- Metric 2-piece hub centering nut
- **Elongated neck** for centering the wheel to the hub
- **Certified American Steel**
- **Each part tested** for thread, fit and finish
- **QUANTITY: 50 per box**

Ascot No.	Mfg. No.	Description
491-00133	X10-PN22B	33mm Hex X 1.5mm Thread



Oil Nut



Oil Stud

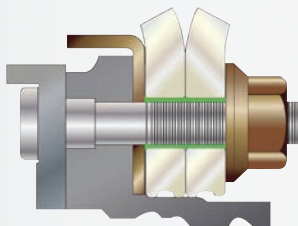

WHEEL ASSEMBLY WITH STANDARD NUT

Void (Highlighted in Green) between stud and hole

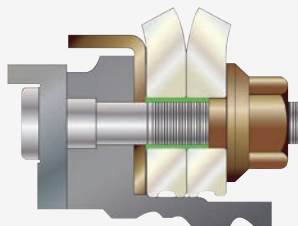

WHEEL ASSEMBLY WITH HUB CENTRIC NUT

Hub Centric Nut fills void between stud and hole

SIDE VIEW



491-00133
Hub Centric Nut



TOP VIEW

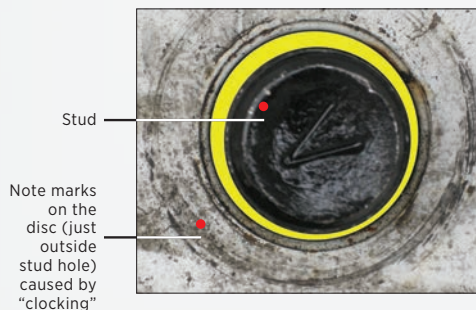

Stud

Note marks on the disc (just outside stud hole) caused by "clocking"

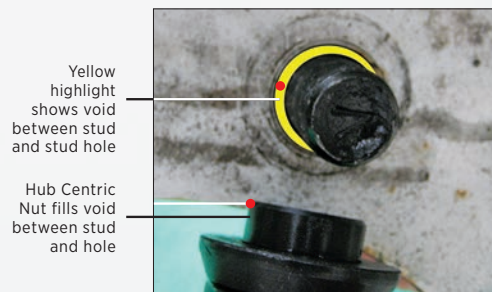

Yellow highlight shows void between stud and stud hole

Hub Centric Nut fills void between stud and hole

This nut had been torqued to specifications and retorqued per factory settings.

TIRE & WHEEL SERVICE TOOLS



WHEELOK SYSTEMS FOR HEAVY DUTY VEHICLES

• **APPLICATION:** For trucks, tractors or trailers with spoke (Dayton) Wheels



401-10430

401-10431

Ascot No.	Mfg. No.	Description
401-10431	X10-DN43Z	Wheelok Nut & Free Spinning Sleeve - 2 Recommended For Each Wheel to Replace 2 Regular Nuts
401-10430	X10-DK43Z	Wheelok Key With Replaceable Pin - "Combination" Determined By Position Of Pins

WHEELOK SYSTEMS FOR HEAVY DUTY VEHICLES: FRONT WHEELS

• **APPLICATION:** For trucks, tractors or trailers with disc (Budd) Wheels; For truck or tractor front wheels

Ascot No.	Mfg. No.	Description
401-10160	X10-BN16Z	Wheelok Nut & Free Spinning Sleeve - Right-Hand Thread - 2 For Each Wheel To Replace 2 Regular Nuts
401-10170	X10-BN17Z	Wheelok Nut & Free Spinning Sleeve - Left-Hand Thread - 2 for Each Wheel to Replace 2 Regular Nuts

WHEELOK SYSTEMS FOR HEAVY DUTY VEHICLES: REAR WHEELS

• **APPLICATION:** For trucks, tractors or trailers with disc (Budd) Wheels; For truck or tractor rear wheels

Ascot No.	Mfg. No.	Description
401-10280	X10-BN28Z	Wheelok Nut Only - Right Hand Thread - 2 For Each Wheel To Replace 2 Regular Nuts
401-10290	X10-BN29Z	Wheelok Nut Only - Left Hand Thread - 2 For Each Wheel To Replace 2 Regular Nuts
401-10810	X10-BK81Z	Wheelok Key With Replaceable Pin - "Combination" Determined By Position Of Pins

WHEELOK SYSTEMS FOR HEAVY DUTY VEHICLES

• **APPLICATION:** For trucks, tractors or trailers with Budd Unimount™ Wheels - 22mm thread or equivalent



401-10220

Ascot No.	Mfg. No.	Description
401-10220	X10-UN22Z	Wheelok Nut, Flange and Free Spinning Sleeve - Combined Into One Single Unit
401-10221	X10-UK22Z	Wheelok Key with Replaceable Pin - "Combination" Determined By Position Of Pins

RIB NUT SALVAGE TOOL KIT

• **INCLUDES:** (1) Drift Pin, (1) Salvage Cylinder, (1) LH Thread Bolt, (1) RH Thread Bolt



499-10150

Ascot No.	Mfg. No.	Description
499-10150	X10-LS15B	Rib Nut Salvage Tool Kit

3-PIECE HEX NUT REMOVER KITS



492-15000

Ascot No.	Mfg. No.	Description
492-15000	X10-NR15B	1-1/2" Hex Nut Remover Kit - 3 Piece
492-14000	X10-NR14B	1-1/4" Hex Nut Remover Kit - 3 Piece

TIRE & WHEEL SERVICE TOOLS



STUD INSTALLERS



492-10158



492-10134

Ascot No.	Mfg. No.	Description
492-10134	X10-SI34Z	For 3/4" Studs. Fits 1-1/4" Socket
492-10150	X10-LC15B	Rib Nut Salvage Cylinder
492-10158	X10-SI58Z	For 5/8" Studs. Fits 1-1/4" Socket
492-10159	X10-SI59Z	For 5/8" x 18 Studs. Fits 1-1/4" Socket
492-10196	X10-SI96Z	For 9/16" x 18 studs. Fits 1-1/4" Socket
492-10590	X10-SI59Z	5/8"- 18 Stud Installer

13/16" SQUARE HEAD ADAPTER

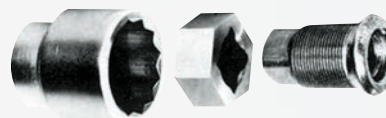

499-10130

Ascot No.	Mfg. No.	Description
499-10130	X10-SA13B	Fits 1-1/2" Socket Wrench to Speed Up Installing Or Removing Budd Wheel Inner Cap Nuts
499-10171	X10-SA17B	17mm Stud Adapter
499-10210	X10-SA21B	21mm Stud Adapter

TRUCK WHEEL STUD INSTALLER

• Prevents damage to your lug nuts or new stud by reducing friction during installation • Works with hubs, rotors and axles • Fits studs up to 22mm (7/8")



492-02278

Ascot No.	Mfg. No.	Description
492-02278	TWS-22	Truck Wheel Stud Installer

TRUCK WHEEL STUD INSTALLER

• Fits truck wheel studs up to 22mm (7/8") in diameter • Use with an impact wrench or ratchet • The tool body is equipped with a thrust bearing to easily pull the new wheel stud into place • Use the lug nut to tighten against the tool body to pull the stud in position



492-28950

Ascot No.	Mfg. No.	Description
492-28950	28950	Truck Wheel Stud Installer

STUD REMOVERS

Ascot No.	Mfg. No.	Description
492-10340	X10-SR34B	For 3/4" Studs. Fits 1-1/4" Socket
492-10580	X10-SR58B	For 5/8" Studs. Fits 1-1/4" Socket
492-10180	X10-SR18B	For 1-1/8" Studs. Fits 1-1/4" Socket
492-10780	X10-SR78B	For 7/8" Studs. Fits 1-1/4" Socket

HEAVY DUTY DRIVE-ON RIB-GRIP LUG-OFF KITS



499-10200

Ascot No.	Mfg. No.	Description
499-10200	X10-LT20B	For Removing Damaged Inner Cap Nuts (1-1/8" Dia. - 13/16" Square Head) INCLUDES: (1) Drive-On Tool And (1) Rib Nut
499-10340	X10-LT34B	For Removing Damaged 3/4" Lug Studs. INCLUDES: (1) Drive-On Tool And (1) Rib Nut
499-10580	X10-LT58B	For Removing Damaged 5/8" Lug Studs. INCLUDES: (1) Drive-On Tool, (1) Rib Nut
499-10660	X10-LT66B	Triple Duty Tool For Removing Damaged Budd Wheel Inner Cap Nuts, 3/4" And 5/8" Lug Studs. INCLUDES: (1) Drive-On Tool and (3) Rib Nuts

REPLACEMENT RIB NUTS

Ascot No.	Mfg. No.	Description
499-10180	X10-LN18B	For Budd Wheel Inner Cap Nuts
499-10341	X10-LN34B	For 3/4" Lug Studs
499-10581	X10-LN58B	For 5/8" Lug Studs
499-10211	X10-LN21B	For 21mm Lug Studs
499-11171	X10-LN17B	For 17mm Lug Studs
492-10151	X10-LP15Z	Drive Pin



HEAVY DUTY WHEEL STUD SERVICE KIT

- Works on most hubs for installation and removal.
- All sizes of studs.
- Installation done by pushing on the head, eliminating the need for threaded adapters.
- Reduces number of adapters required
- Reduces damage to studs
- Increases ease of use
- Remove and install 10 studs in only 10-15 minutes (compare to 20-30 minutes for more expensive competitive products).
- Can be powered with an impact wrench, no hydraulic power source required.
- No need to remove hub from vehicle.
- Reduces risk of damage to hubs, studs, and bearings when using tool.
- Weighs only 12 lbs., assembled to remove studs and 14 lbs., assembled to install studs.

Ascot No.	Mfg. No.	Description
493-91420	NS-9142	Heavy Duty Wheel Stud Service Kit



493-91420
Wheel Stud Service Kit

ALCOA WHEEL INSTALLATION SLEEVES

- **Align wheel bolt holes** • Seat brake drums that have .980" diameter bolt holes • Prevent damage to M22x1.5 studs • Assist in lining up all components for ease of install • **INCLUDES:** 2 tools per kit • **Made in USA**



491-00426

Ascot No.	Mfg. No.	Description
491-00426	407422	Alcoa Wheel Installation Sleeves



401-69290

Ascot No.	Mfg. No.	Description
401-69290	69290	Chamfer Nut Gauge



UNI-MOUNT M22 THREAD PITCH GAUGE

- **APPLICATION:** Designed for M22 x 1.5 Uni-Mount Studs
- If the thread teeth do not fully engage the stud, the stud should be removed from service
- Simple to use

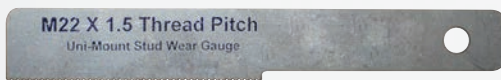

401-69260

Ascot No.	Mfg. No.	Description
401-69260	62960	Uni-Mount Thread Gauge



ALCOA RIM FLANGE WEAR GAUGE

- Determines if wheel must be removed from service due to excessive rim flange wear



401-00700

Ascot No.	Mfg. No.	Description
401-00700	00700	Alcoa Rim Flange Wear Gauge



STUD & HUB CLEANING TOOLS



STUD CLEANING TOOLS

- Allows for cleaning the full length of the thread on 10 studs in less than 3 minutes
- Works with air or hand tools
- CAUTION: Always use eye protection
- 1/2" adapter included with each tool
- Replacement Brushes Available



QUICK & EASY TO USE

WORKS WITH AIR OR HAND TOOLS



Replacement Brush for Stud Cleaning Tool

Ascot No.	Mfg. No.	Description
REPLACEMENT BRUSHES FOR STUD CLEANING TOOLS		
402-00112	SBR12	12mm (7/16") Repl. Brush
402-00113	SBR13	13mm (1/2") Repl. Brush
402-00014	SBR14	14mm (9/16") Repl. Brush
402-00016	SBR16	16mm (5/8") Repl. Brush
402-00118	SBR18	18mm (45/64") Repl. Brush
402-00120	SBR20	20mm (25/32") Repl. Brush
402-00122	SBR22	22mm (7/8") Repl. Brush
402-00128	SBR28	28mm (1-1/8") Repl. Brush

Ascot No.	Mfg. No.	Description
402-00013	SBCT-13	13mm (1/2") Stud Cleaning Tool
402-00022	SBCT-22	22mm (7/8") Stud Cleaning Tool
402-00028	SBCT28	28mm (1-1/8") Stud Cleaning Tool

WHEEL HUB GRINDER

- Special grinder for cleaning the wheel centering device as well as the attachment area between the wheel and hub
- Burned in corrosion residues are completely removed in a quick and easy process
- Actual cleaning time per hub only takes between 3-25 seconds depending upon residue thickness
- Replacement Discs Available

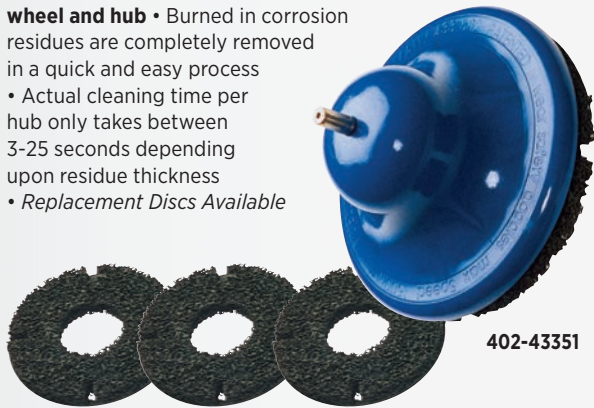

Ascot No.	Mfg. No.	Description
402-43352		
402-43352	433 502/M	Wheel Hub Grinder
402-43351	433 501	Grinder Replacement Discs (3 per package)

INNER RIM CLEANER AND REPLACEMENT DISCS

- Meant for the optimal cleaning of the inner wheel contact surface
- Prevents corrosion related distortion of wheel bolt tightening torque
- Allows for the complete removal of burnt in corrosion
- Used only on the inside of an aluminum rim
- Velcro adhesive makes it easy to change out replacement discs
- 75mm diameter in size
- **REPLACEMENT DISCS AVAILABLE:** 3 per box



Ascot No.	Mfg. No.	Description
402-43358		
402-43357	433 507	Inner Rim Cleaner
402-43358	433 508	Replacement Discs (3 per Box)



IMPACT WHEEL HUB CLEANER

- Large diameter for cleaning wheel mounting surface
- Ideal for European lug bolt hub cleaning
- 160mm x 65mm diameter
- 1/2" impact rated
- Strip-Away style abrasive ensures long life and durability
- Springlock release makes changing pads effortless
- 1/2" square drive replacement strip disk available (37355)



Ascot No.	Mfg. No.	Description
402-37350	37350	Impact Wheel Hub Cleaner
402-37351	37351	Wheel Hub Cleaner Disc
402-37355	37355	Wheel Hub Cleaner Strip Disc

NEW



PROFESSIONAL STUD/HUB BRUSH KIT

- Ideal for hub and stud cleaning job with ease • **QUICK AND EASY:** Change brushes in seconds • Includes a 1/2" drive adapter
- Powered by a cordless drill • Replacement brushes available



QUICK & EASY TO USE

402-32610



402-32613



402-32615

Ascot No.	Mfg. No.	Description
REPLACEMENT COMPONENTS FOR STUD/HUB BRUSH KIT		
402-32611	203611-ASC	Plastic Hub/Stud Tool & Adapter
402-32613	203613-ASC	4-Pack of Replacement 14mm Stud Brushes
402-32614	203614-ASC	4-Pack of Replacement 22mm Stud Brushes
402-32615	203615-ASC	4-Pack of Replacement Passenger Hub Brushes
402-32616	203616-ASC	4-Pack of Replacement Truck Hub Brushes

Ascot No.	Mfg. No.	Description
402-32610	203610-ASC	Stud/Hub Brush Kit

STUD CLEANING KIT

- Quickly and effectively clean rust and corrosion from wheel studs
- Manufactured from one single piece of anodized aluminum for increased durability
- Designed for use with Auto, Light Truck, SUV, Utility Trailers, Commercial Truck and Bus applications
- Contains everything you need to clean a wide variety of wheels in one handy kit



402-01322

KIT CONTAINS:

- SBCT22 with a SBR22 brush
- Safety glasses
- 2 adapters
- 2 hex keys

REPLACEMENT BRUSHES: SBR 12,13,14,16, 18, 20 and 22mm

Ascot No.	Mfg. No.	Description
402-01322	SKT-1322	Stud Cleaning Kit

HUB BUDDY TOOL

- **IMPACT RATED:** No need to change tools
- Complies with best practice R.I.S.T. procedure
- Removes rust, corrosion and other build-up from wheel stud, drums and tire rim
- Helps proper torque of lug nuts by removing corrosion
- A must for easy and accurate tire balancing
- **INCLUDES:** 1 Hub Buddy XL attachment and 1 cleaning disc head
- Replacement cleaning discs available in packs of 6 (Product # 402-37335)



402-37330

402-37335

Ascot No.	Mfg. No.	Description
402-37330	37330	Hub Buddy Tool
402-37335	37335	2" Hub Buddy Tool Replacement Pads
402-37340	37340	1-1/2" Hub Buddy Tool Replacement Pads

STUD & HUB CLEANING TOOLS



CRIMPED ENCAPSULATED WIRE WHEELS

- Elastomer gradually wears exposing consistent short trim for maximum aggression and long life

Ascot No.	Mfg. No.	Size	Width/Face	Arbor	Fill Wire	Wire Dia.	Trim Length	RPM
535-14164	14164	3"	1/4"	1/2"	Steel	0.018"	1"	20,000
535-14181	14181	3"	1/4"	1/2"	Steel	0.014"	1"	20,000



535-14164



535-14181

KNOTTED END AND POWER BRUSHES

- Features a hollow end and heavy duty brushing action with some flexibility
- Ideal for more demanding cleaning applications in recessed areas

Ascot No.	Mfg. No.	Style	Size	Width/Face	Arbor	Fill Wire	Wire Dia.	Trim Length	RPM
535-14174	14174	Single Row Knotted Wire Cup Brush	3-1/4"	3/8"	1/4" Shank	Steel	0.014"	5/8"	25,000
535-14177	14177	Twist Knot Brush	4"	1/2"	1/2"-3/8"	Steel	0.020"	7/8"	25,000
535-14178	14178	Knotted End Brush	3"	3/8"	1/2"-3/8"	Steel	0.014"	5/8"	25,000



535-14174



535-14177



535-14178

3" - 10" POWER BRUSHES

- Provide heavy duty brushing action with some flexibility
- Ideal for demanding cleaning applications on somewhat irregular surfaces

Ascot No.	Mfg. No.	Style	Size	Width/Face	Arbor	Fill Wire	Wire Dia.	Trim Length	RPM
535-14165	14165	Twist Knot	3"	3/8"	1/2"-3/8"	Steel	0.014"	5/8"	25,000
535-14170	14170	Mounted Knot	3-1/4"	3/8"	1/4" Shank	Steel	0.014"	5/8"	25,000
535-14171	14171	Twist Knot	4"	1/2"	1/2"-3/8"	Steel	0.0118"	7/8"	25,000
535-14172	14172	Twist Knot	4"	1/2"	1/2"-3/8"	Steel	0.014"	7/8"	25,000
535-14173	14173	Twist Knot	4"	1/2"	5/8"-11	Steel	0.020"	7/8"	25,000
535-14175	14175	Twist Knot	4"	1/2"	1/2"-3/8"	Steel	0.020"	7/8"	25,000
535-14176	14176	Cable Twist Knot	4"	1/4"	1/2"-3/8"	Steel	0.020"	7/8"	25,000
535-14179	14179	Cable Twist Knot	10"	1-3/4"	2"	Steel	0.023"	1-3/4"	4,500
535-14182	17682	Mounted Knot	3-1/4"	3/8"	1/4" Shank	Steel	0.020"	5/8"	25,000

535-14165

535-14171



535-14170



535-14172

535-14175



535-14173



Ascot No.	Mfg. No.	Style	Size	Width/Face	Arbor	Fill Wire	Wire Dia.	Trim Length	RPM
535-14176	14176	Cable Twist Knot	4"	1/4"	1/2"-3/8"	Steel	0.020"	7/8"	25,000
535-14179	14179	Cable Twist Knot	10"	1-3/4"	2"	Steel	0.023"	1-3/4"	4,500
535-14182	17682	Mounted Knot	3-1/4"	3/8"	1/4" Shank	Steel	0.020"	5/8"	25,000

535-14176

535-14182



535-14179



HEAVY DUTY SERVICE EQUIPMENT



32225B



**22 TON PIN STYLE
JACK STANDS**

46500



**500 LB DPF/STEP
HOUSING HANDLER**

23221C



**22 TON AIR/HYD
AXLE JACK**

23222C



**22 TON LOW PROFILE
AIR/HYD AXLE JACK**

25057



**5 TON MAGICLIFT™
HYDRAULIC
SERVICE JACK**

25107



**10 TON MAGICLIFT™
HYDRAULIC
SERVICE JACK**

32105B



**10 TON PIN STYLE
JACK STANDS**

32107B



**10 TON HIGH LIFT
JACK STANDS**

34100



**10 TON AIR JACK/
SUPPORT STAND**

43000



**1½ TON FLOOR
STYLE HYDRAULIC
TRANSMISSION JACK**

HW93806



3 TON ENGINE CRANE

HW93776



3 TON ENGINE STAND



BOTTLE JACKS



301-76312
12-Ton Air/
Hydraulic
Bottle Jack

12 AND 20-TON CAPACITY AIR HYDRAULIC BOTTLE JACKS

- Fast efficient air pump reduces lifting time and has a built-in relief mechanism which prevents the jack from being used beyond its maximum capacity
- Convenient push button air valve connected to an in-line filter prevents contaminants from entering the air/hydraulic system
- Unique design allows for manual operation when air is not available
- Two piece zinc plated handle
- Parkerized coating on pump piston, extension screw and extension adapters and chrome coated ram offer protection against rust
- Longer wear life due to internally machined oil passages, smooth bearing surfaces and close tolerances
- Safety oil by-pass system prevents the ram from being overextended and causing damage to the cylinder

Ascot No.	Mfg. No.	Capacity	Min. Height	Max. Height	Lifting Handle
301-76312	76312A	12-Ton	9-15/16"	19-3/4"	23.5"
301-76320	76320A	20-Ton	10-7/8"	20-1/2"	23.5"
301-76720	76720A	12-Ton	8-1/4"	14-1/2"	23.5"
301-76721	76721A	20-Ton	7-3/4"	11-3/4"	23.5"

12 AND 20-TON CAPACITY BOTTLE JACKS



HEAVY DUTY

12 AND 20-TON CAPACITY BOTTLE JACKS

- For heavy duty truck, agriculture, construction, mining, mobile home, oil field, automotive, and marine applications where lifting, pushing, spreading, bending, pressing, or straightening are required
- Two-piece zinc plated handle
- Prevent rust with "Parkerized" pump piston, ram and extension screw
- No leak "Uniweld" construction
- Longer wear life due to internally machined oil passages, smooth bearing surfaces and close tolerances
- State of the art design reduces repair time
- 50% safety overload factor
- Lightweight forged base provides more steel only where strength is required
- The heavy-duty extension screw and release valve were designed to eliminate parts and reduce the chances of breakage and excessive wear
- Safety bypass and overload systems prevent cylinder damage and prevent the jack from being used beyond the ASME/PASE load-limiting standard
- Carrying Handles

Ascot No.	Mfg. No.	Capacity	Min. Height	Max. Height	Lifting Handle
301-76412	76412B	12-Ton	9-7/16"	18-7/8"	Yes
301-76512	76512B	12-Ton	6-11/16"	13-3/16"	Yes
301-76520	76520A	20-Ton	10-13/16"	20-3/16"	Yes
301-76820	76820A	20-Ton	8-1/4"	14-15/16"	Yes

OMEGALIFT

AIR-ACTUATED & MANUAL HYDRAULIC BOTTLE JACKS

- Effortless air operation will greatly reduce operator fatigue and speed up the efficiency of garage work
- The motor is equipped to raise the load to the desired height efficiently, effortlessly and safely
- A compact, yet powerful Air Turbo
- All air bottle jacks come with chrome plated rams
- Versatile “Quick Connector” design provides for easy removal of air hose from air motor allowing compact storage or remote operation

Ascot No.	Mfg. No.	Cap.	Min. Height	Max. Height	Hyd. Height	Ext. Screw	Base Size	WT. (Lb.)
301-18126	18126C	12-Ton	9-5/8"	18-7/8"	5-1/2"	6"	8" x 5-1/4"	27
301-18204	18204C	20-Ton	10"	18-3/4"	4-7/8"	3-7/8"	8-1/2" x 7-1/8"	34
301-18206	18206C	12-Ton	9-5/8"	19"	5"	6"	9" x 7"	37
301-18209	18209B	20-Ton	8"	15-1/2"	4-1/8"	3-1/4"	8-1/2" x 7-1/4"	37
301-18302	18302C	30-Ton	11"	18"	7"	N/A	10-1/4" x 8-1/4"	63
301-18502	18502	50-Ton	12"	19"	7"	n/a	10-7/8" X 7-3/8"	134-1/2
301-18992	18992	100-Ton	11-7/8"	17-7/8"	6"	n/a	12-3/4" X 9-3/8"	220-1/2



301-18204
20-Ton Air/Manual Hydraulic Bottle Jack

HYDRAULIC SIDE PUMP BOTTLE JACKS

- Hydraulic system is protected from internal damage by a patented bypass mechanism
- Machined and polished cylinders with die-cut threads provide non-abrasive leak-free, durable performance
- Fabricated from hard-cast steel with heat-treated critical stress areas
- Unique cross-type forged release valve assures positive control
- A wide, rugged base provides stability and strength

Ascot No.	Mfg. No.	Capacity	Min. Height	Max. Height	Hyd. Height	Ext. Screw	Base Size	Wt. (Lbs.)
301-10125	10125B	12-Ton	9-1/2"	18-5/8"	6"	3-1/8"	6" x 5-3/8"	18
301-10129	10129B	12-Ton	6"	10-5/8"	3"	1-5/8"	6" x 5-3/8"	14
301-10205	10205B	20-Ton	9-1/2"	18-5/8"	6"	3-3/8"	6-3/8" x 5-7/8"	28
301-10209	10209B	20-Ton	6-1/2"	11-1/4"	3-1/8"	1-5/8"	6-3/8" x 5-7/8"	21
301-10300	10300	30-Ton	11"	18"	7"	n/a	8-1/8" x 6-7/8"	56
301-10500	10500	50-Ton	9-1/2"	13-7/8"	4-3/8"	n/a	10-3/4" x 7-5/8"	103-1/2



301-10125

301-10205

HYDRAULIC IN-LINE BOTTLE JACKS

- Heat-treated extension screw allows low pick-up height adjustment and maximum lift height
- Easiest accessible pumping system eliminates off-center pumping force for the most efficient operation
- A wide, rugged base provides stability and strength
- U.S. Patented built-in by-pass device protects hydraulic system from over pumping damage
- Unique cross-type forged release valve assures positive control

Ascot No.	Mfg. No.	Capacity	Min. Height	Max. Height	Hyd. Height	Ext. Screw	Base Size	Wt. (Lbs.)
301-10120	10120	12-Ton	9-1/2"	18-5/8"	6"	3-1/8"	7" x 4-1/4"	19-1/2
301-10200	10200	20-Ton	9-1/2"	18-5/8"	6"	3-1/8"	7-3/4" x 5"	27
301-10208	10208	20-Ton	6-1/2"	11-1/4"	3-1/8"	1-5/8"	7-3/4" x 5"	22



301-10120

301-10208

BOTTLE JACKS



301-02201

301-01220

301-01201

12 AND 22-TON CAPACITY LOW FORGED STEEL BASE BOTTLE JACKS

- Welded steel construction throughout - reduces metal fatigue allowing for longer use life
- Unique base forging method increases resistance to high pressure and gives a degree of durability
- Needle valve allows for controlled lowering of the ram
- Special type of steel resists rust
- Casing, cylinder and base are joined by electric resistance welding for greater strength and are leak proof
- Heat treated extension screw provides low pickup height adjustment, maximum lift height and extra strength

Ascot No.	Mfg. No.	Capacity	Min. Height	Max. Height	Ram Lift	Screw Ext.	Base Size	Ship Wt.
STANDARD								
301-01220	ZN-12	12-Ton	9-1/2"	18-1/2"	5-7/8"	3-1/8"	4-1/8" x 6-1/2"	18 Lbs.
301-02200	ZN-22	22-Ton	10-5/8"	20-1/8"	6-1/4"	3-1/4"	5" x 7-1/8"	30 Lbs.
LOW								
301-01201	ZNB-12	12-Ton	6-3/4"	13-3/8"	3-3/4"	3"	4-1/8" x 6-1/2"	15 Lbs.
301-02201	ZNB-22	22-Ton	7-1/8"	12"	3-3/8"	1-1/2"	5 x 7-1/8"	27 Lbs.



301-41020

301-41040

301-41200

301-41300

2 TO 30-TON CAPACITY BOTTLE JACKS

- All models have a chrome main ram and a chrome pump piston
- The extension screws have a pressed thread
- These units can be used horizontally and vertically



Ascot No.	Mfg. No.	Capacity	Min. Height	Max. Height	Ext. Screw
301-41020	G410200	2-Ton	6-1/4"	11-3/4"	2"
301-41040	G410400	4-Ton	7-1/2"	14-1/2"	2"
301-41060	G410600	6-Ton	7-3/4"	14-3/4"	2"
301-41080	G410800	8-Ton	9"	18"	3-1/4"
301-41150	G411500	15-Ton	9-3/4"	19-1/4"	3-1/4"
301-41200	G412000	20-Ton	9-1/2"	18-1/2"	3-1/4"
301-41201	G412001	20-Ton Short	6-1/2"	11-1/4"	1-1/2"
301-41300	G413000	30-Ton	9-1/2"	18-1/2"	3"



301-43220
20-Ton Air/Hydraulic Bottle Jack

20-TON AIR/HYDRAULIC BOTTLE JACK

- Unit includes a welded base to prolong service and return springs
- Chrome main ram and aluminum air motor guarantee optimum lifetime
- Air filter, connected to hose, included

Ascot No.	Mfg. No.	Capacity	Min. Height	Max. Height	Ext. Screw
301-43220	G432020	22-Ton	9-3/4"	18-1/2"	3-1/4"



12 AND 20-TON SHORT WELDED BOTTLE JACKS

- Welded cylinder and reservoir for added strength and durability
- Chrome plated rams to resist rust and wear
- Built-in bypass device to protect hydraulic system from over pumping damage



301-61124



301-61200

12 AND 20-TON IN-LINE WELDED BOTTLE JACKS

- Welded cylinder and reservoir for added strength and durability
- Chrome plated rams to resist rust and wear
- Built-in bypass device to protect hydraulic system from over pumping damage



301-61120

BOTTLE JACK SPECIFICATIONS

Ascot No.	Mfg. No.	Capacity	Min. Hgt.	Max. Hgt.	Overall Length	Overall Width	Saddle Diameter	Shipping Weight
301-61200	61200	20 Tons	10-1/2"	20-1/2"	7-1/2"	5-1/8"	1-3/4"	28.1 lb.
301-61120	61120	12 Tons	9-3/8"	18-5/8"	6-1/2"	4-3/8"	1-1/2"	18.9 lb.
301-61124	61124	12 Tons	6-3/4"	13-3/8"	6-1/2"	4-3/8"	1-1/2"	15.4 lb.



BOTTLE JACKS

PREMIUM AIR/HYDRAULIC BOTTLE JACK

- Chromed ram and aluminum air motor piston for longer life
- Heavy duty return springs
- Each unit factory tested at 150% overload
- **CAPACITY:** 20-Ton
- **MIN. HEIGHT:** 9.7" (24.5 cm)
- **MAX HEIGHT:** 18.5" (46 cm)
- **WEIGHT:** 38 lbs. (17.5 kg)
- Internal limiting washer installed to prevent side loading of the cylinder
- In-line regulator for continuous optimal air pressure
- Improved ergonomic handle
- Flexzilla style hose for maximum durability

Ascot No.	Mfg. No.	Description
301-14455	14455	Premium Air/Hydraulic Bottle Jack



301-14455

TITAN AIR/HYDRAULIC BOTTLE JACKS

- **Cylinder is welded to the base, assuring strength and eliminating leaks**
- Chromed pump piston and ram for added rust resistance
- Extension screw gives added height when necessary
- Super low minimum height for easy access

Ascot No.	Mfg. No.	Cap.	Min. Height	Max. Height	WT. (LB.)
301-14460	14460	20-Ton	9-3/4"	18-1/2"	38
301-14461	14464	20-Ton	5/8"	10'	21
301-14475	14475	30-Ton	11"	18"	60
301-14480	14480	50-Ton	12"	19"	138



301-14460

TITAN 20-TON SHORT AIR/HYDRAULIC BOTTLE JACK

- **Cylinder is welded to the base, assuring strength and eliminating leaks**
- Chromed pump piston and ram for added rust resistance
- Extension screw gives added height when necessary
- Super low minimum height for easy access
- Meets ANS/ASME PALD & CE/GS standards
- **MEASUREMENTS (L X W X H):** 13" x 5" x 6"
- **MIN. HEIGHT:** 5.8" (148mm)
- **MAX HEIGHT:** 10" (256mm)
- **WEIGHT:** 9.5 kg/21 lb.

Ascot No.	Mfg. No.	Description
301-14461	14461	Titan 20-Ton Short Air/Hydraulic Bottle Jack



301-14461



AMERICANFORGE&FOUNDRY™

20 AND 30-TON CAPACITY SUPER DUTY AIR/HYDRAULIC BOTTLE JACKS

- Welded tank and frame for superior strength
- Thick base design provides the most stable lifting platform
- Dual return springs help provide controlled and easy descent
- Shielded release screw prevents accidental lowering
- Specially engineered air motor for consistent and reliable operation

WELDED
TANK &
FRAME

THICK
BASE
DESIGN

301-05620



301-05621



301-05630



BOTTLE JACK SPECIFICATIONS

Ascot No.	Mfg. No.	Capacity	Min. Height	Max. Height	Lift	Base Size	Air Pressure	Air Inlet	WT. (Lbs)
301-05620	5620SD	20-Ton	10-37/100"	20-63/100"	6-19/50"	5-3/4" x 9"	110-120 PSI	1/4" NPT	45
301-05621	5621SD	20-Ton	7"	12-3/4"	3-7/20"	5-7/10" x 8-27/100"	110-120 PSI	1/4" NPT	36
301-05630	5630SD	30-Ton	10-47/50"	20-59/100"	5-91/100"	9-13/20" x 7-9/100"	110-120 PSI	1/4" NPT	65



BOTTLE JACKS



20 AND 30-TON CAPACITY PRO SERIES AIR/HYDRAULIC BOTTLE JACKS

- Fully welded cylinder and frame provide superior strength and extended service life
- Extra thick jack base provides exceptional support and stability in severe conditions.
- Quick-connect feature on air valve allows easy disconnect/connection of air hose and more compact storage.
- Dust rings on the top of pump piston provide extra protection for the cylinder and extended service life.
- Chrome plated pump piston and ram for extra rust and corrosion resistance.
- Cast steel handle socket and linkage provide exceptional strength and durability

EXTRA
THICK
BASE



301-10381



301-10382



301-10383

BOTTLE JACK SPECIFICATIONS

Ascot No.	Mfg. No.	Capacity	Min. Height	Max. Height	Lift	Base Size	Base Thickness	Air Pressure	Air Inlet	WT. (Lbs)
301-10381	10381	20-Ton	10 in.	20 in.	6 in.	8.875" x 5.75"	1.25 in.	110-125 PSI	1/4 in. NPT	41 lbs.
301-10382	10382	20-Ton Shorty	7.125 in.	12.625 in.	3.25 in.	8.25" x 5.75"	1.25 in.	110-125 PSI	1/4 in. NPT	34 lbs.
301-10383	10383	30-Ton	10.875 in.	20 in.	6 in.	9.625" x 7.125"	1.5 in.	110-125 PSI	1/4 in. NPT	63 lbs.

JACK PLATES



JACK PLATES

- **SIZES AVAILABLE:** 12" x 12" x 1" and 18" x 18" x 1"
- 100-ton capacity for both sizes
- Provides stability to bottle jacks, hydraulic rams, jack stands and cribbing
- Non-skid surface
- Constructed of engineered thermoplastic material
- **MADE IN THE USA**



Ascot No.	Mfg. No.	Description
309-12121	D1212	12" x 12" x 1" Jack Plate
309-18181	D1818	18" x 18" x 1" Jack Plate

GRIP-IT SERIES JACK PLATES

- New pyramid surface on one side is designed to mate with Super Stacker Cribbing Blocks pyramid surface for secure, exact fit, as well as provide better grip onto uneven terrain in the field
- Provides increased stability and gripping surface
- Complies with OSHA regulation 29 CFR 1926.305
- Capacity: 100 tons
- Model 14503 bottom locking plate locks onto Super Stacking Cribbing, helping to secure the load while preventing the release of hazardous energy



Ascot No.	Mfg. No.	Type	Dimensions	Capacity	Wt. (Lbs.)
309-14500	14500	Standard Plate	12" x 12' x 2"	100-Ton	8.8
309-14501	14501	Standard Plate	12" x 24' x 2"	100-Ton	17.8
309-24468	14468B	Standard Plate	24" x 24' x 2"	100-Ton	36.3
309-14503	14503	Bottom Locking Plate	27" x 24" x 2"	100-Ton	38.4

TITAN JACK PLATES

- Each unit has non-skid surface to prevent jacks from sliding under wet or oily conditions
- Lightweight and easy to handle
- When it is necessary to provide a firm foundation, the base of the jack shall be blocked or cribbed



The Titan Jack Plate in use.



Ascot No.	Mfg. No.	Dimensions	Capacity	Wt. (Lbs.)
309-14464	14464	12" x 12" x 1"	50-Ton	5
309-14465	14465	12" x 12" x 1.5"	100-Ton	8
309-14466	14466	18" x 8" x 3"	200-Ton	21
309-14468	14468	24" x 24" x 2"	100-Ton	24
309-14472	14472	18" x 18" x 1"	50-Ton	15
309-14473	14473	18" x 18" x 1.5"	100-Ton	16
309-14462	14462	36" x 36" x 2.5"	150-Ton	118
309-14463	14463	36" x 36" x 3"	200-Ton	135
309-14469	14469	18" x 18" x 2"	100-Ton	20



SERVICE JACKS

20-TON AIR/HYDRAULIC BOTTLE JACKS

- Thick jack base provides exceptional support and stability in severe conditions
- Quick-connect feature on air valve allows easy disconnect and connection of air hose & more compact storage

22-TON AIR/HYDRAULIC TRUCK JACK

- Large air motor provides an exceptional quick lifting experience
- Narrow chassis fits between tandem truck wheels
- Comes with three adapters in different sizes that cater to different working requirements



Ascot No.	Mfg. No.	Description	Min. Hgt.	Max Hgt.	Hyd. Lift Range	Exten. Screw	Chassis Size	Saddle Size	Handle Length	Ship Wt. (Lbs)
301-20220	AS2022	20-Ton Air/Hydraulic Bottle Jack	10-1/8"	19-7/8"	6-1/2"	3-1/8"	N/A	N/A	9-3/8"	35.1
301-20221	AS2022S	20-Ton Short Air/Hydraulic Bottle Jack	7"	12-5/8"	3-3/8"	2-3/9"	N/A	N/A	9-3/8"	30.6
302-19150	AS1915	22-Ton Air/Hydraulic Truck Jack	10-1/2"	21-1/8"	6-1/8"	4-1/2"	N/A	N/A	45-1/4"	101.9

20-TON CAPACITY AIR/HYDRAULIC SERVICE JACK

- Compact, powerful design quickly lifts rated capacity
- Large 8" rubber wheels
- Low height allows lifting from axle or suspension
- Pressure relief valve prevents overloading
- Rapid two-speed air hydraulic action quickly advances ram to load
- Chrome plated plunger for extended jack life
- Optional height adapters HW93265
- 2 Year Warranty



302-93733

Ascot No.	Mfg. No.	Capacity	Min. / Max. Height	Power Raise	Handle Length	Base Size	EXT. Screw	Operating Pressure	Wt. (Lb.)
302-93733	HW93733	20 Tons	9" /19-3/4"	6"	52-1/2"	8" x 17"	4-3/4"	110-140 PSI	88-1/2

20-TON TITAN AIR/HYDRAULIC CART JACK

- 20-ton capacity with welded steel base
- Chromed ram and aluminum air motor for long life
- Heavy duty return springs
- Each unit factory tested at 150% overload
- 36" long handle allows for easy placement of jack under vehicle



302-14470
20-Ton Titan Air/Hydraulic Cart Jack

Ascot No.	Mfg. No.	Capacity	Min. Hgt. / Max. Hgt.	Handle Length	Wt. (Lb.)
302-14470	14470	20 Tons	10" x 19"	36"	55

20-TON AIR/HYDRAULIC SERVICE JACKS WITH CART

- Unit includes a welded base to prolong service
- Chrome main ram and aluminium air motor guarantee optimum lifetime
- Air filter, connected to hose, included
- Comes on trolley

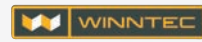

302-43202
20-Ton Air/Hydraulic Service Jack with Cart



Ascot No.	Mfg. No.	Capacity	Min. Height / Max. Height
302-43202	G432003	20 Tons	10" / 18-1/2"

20-TON CAPACITY AIR OPERATED HYDRAULIC FLOOR JACKS

- Intended for heavy duty truck, agricultural and heavy construction equipment
- Designed for use on mobile service trucks
- Long handle with 45-1/2" reach helps in positioning of jack under vehicles with low overhang
- Removable handle for shipment or storage
- Hand grip also works as a stand to store the jack in a vertical position
- Compact design fits easily between tandem wheels
- Fast efficient air pump reduces lifting time and has a built-in relief mechanism which prevents the jack from being used beyond its maximum capacity



302-72091
20-Ton Capacity Air Operated Hydraulic Floor Jacks

Ascot No.	Mfg. No.	Capacity	Min. Height	Max. Height	Wt. (Lbs.)
302-72081	72080A	20-Ton	11-1/8"	28-5/8"	70
302-72091	72090A	20-Ton	8-5/5"	22-3/4"	63

SERVICE JACKS

22-TON CAPACITY AXLE JACK

- Heat treated cylinder wall & chromed piston give added stability & longer jack life
- Alloy steel lifting mechanism for added durability and operator safety
- Precision engineered tolerances for maximum performance
- In-line filter to protect air motor from contaminants
- Corrosion-resistant aluminum and nylon composite air motor
- Ram extension kit included with 3/4", 2-3/4" and 4" extensions
- Large 7-3/4" rear wheels for easy positioning
- Automatic in-line oiler to lubricate air motor
- Grommet retainers-no need for clevis pins
- One-piece handle

Ascot No.	Mfg. No.	Capacity	Min. / Max Hgt.	RAM Lift	Reach	Width	Wt. (Lb.)
302-56501	565E1	22 Tons	8-3/4" x 21-1/2"	4-3/4"	61"	13"	107



CHROMED PISTON

HEAT TREATED CYLINDER WALL

22-TON CAPACITY AIR/HYDRAULIC FLOOR JACKS

- Long "T" handle helps in positioning jack under vehicles with low overhang
- Jack load release top mounted at "T" handle and allows operation at any handle position
- Handle locking lever secures handle in either vertical, horizontal or 45° position
- Compact design fits easily between tandem wheels
- Rust inhibitive coating on ram and extension screw
- Large diameter wheels for easy maneuverability
- Self-retracting ram eliminates manual lowering of jack
- *Includes 3-piece extension set*

Ascot No.	Mfg. No.	Capacity	Min. Height	Max. Height	Ext. Screw	Wt. (Lbs.)
302-72200	72200D	22-Ton	9"	18"	—	102
302-00224	ZATJ-22S-4	22-Ton	8"	15-7/8"	3-5/8"	82
302-23221	23221C	22-Ton	9-3/4"	23-5/8"	3-7/8"	100



35-TON CAPACITY SERVICE JACK

- Carries a very wide hydraulic cylinder and three heavy duty wide adaptors to give it stability when lifting loads that tend to shift
- Solid base makes the new jack very durable and safe to operate
- Provides a low minimum height facility enabling clearance on vehicles with low suspension
- Three adaptors as options this product is able to lift high trailer assemblies loaded or unloaded without issue
- Recommended for carrying out up to a minimum of 30,000 lifts without fail
- 3 Year Warranty

Ascot No.	Mfg. No.	Capacity	MIN. / MAX. HGT.	Wt. (Lb.)
302-03531	GT-3531	35 Tons	7-9/32" / 16-11/16"	93



24-TON CAPACITY SERVICE JACK

- This single stage air service jack delivers 24 Tons of lifting power
- It is designed to meet and exceed the expectations of a quality jack at a very competitive price
- The G432024 comes equipped with an extension screw, individual extension pegs, and heavy duty wheels designed for daily use

Ascot No.	Mfg. No.	Description
302-43222	G432024	24-Ton Service Jack



25-TON BLACKHAWK PLATINUM AIR/HYDRAULIC JACK

- Chrome-plated ram
- Improved bearing surfaces
- High cycle durability
- Long life seals
- High/low temp functionality
- 5-year warranty with electronic registration
- Made in Taiwan

Ascot No.	Mfg. No.	Capacity	Min. Height	Max. Height	Saddle Extensions
302-00225	BP225	25 Tons	9-5/32"	22" w/ Ext.	1", 2.5", 6" & 7"

HANDLE PROTECTORS

- Made of a durable synthetic rubber
- Fits multiple jack manufacturers' handles and popular tire tools
- Unique design ensures a tight fit on jack/tool handle without slippage
- Protects vehicles from scratches or dents caused by falling jack handles and unstable tools in the shop
- Patent Pending design absorbs the dent/scratch-causing force as the handle contacts an adjacent vehicle

Ascot No.	Mfg. No.	Description
448-01101	GHP-01 B	Black Handle Protector
448-01102	GHP-01 Y	Yellow Handle Protector
448-01103	GHP-01 R	Red Handle Protector



302-03531

302-43222

302-00225



448-01101



448-01102



448-01103



SERVICE JACKS



2, 3, 5, 10 & 20-TON CAPACITY FLOOR SERVICE JACKS

- Steel hydraulic block assembly includes dust seals to prevent oil contamination
- 5, 10 & 20-ton capacity jacks have one-pump to load feature
- Long, removable two-piece handle
- Safety bypass system protects cylinder
- Safety overload system prevents jack from being used beyond rated capacity
- 5, 10 and 20-ton floor jacks feature a US patented one pump to load ability, reducing lift time dramatically. 71202A takes 10 pumps to full rise under load
- 71202A features nylon wheels to protect epoxy and tile floors

Ascot No.	Mfg. No.	Capacity	Min. / Max. Hgt.	Handle Length	Wt. (Lb.)
302-71000	71000D	10 Tons	6-1/2" / 27-1/4"	46-3/4"	455
302-71100	71100A	10 Tons	6-1/2" / 27-1/4"	46-3/4"	466
302-71203	71203	3 Tons	3-1/5" / 20-3/8"	40"	112
302-71233	71233A	2 Tons	2-3/4" / 20"	50-1/4"	92
302-71331	71331	3 Tons	3-3/4" / 19"	48"	59
302-71335	71335	3-1/2 Tons	4" / 21-3/8"	48"	106
302-71500	71500G	5 Tons	6-1/4" / 27-1/4"	42-1/2"	119
302-71550	71550G	5 Tons	6-1/4" / 26-1/4"	45"	270
302-72220	72220A	20 Tons	6-1/2" / 26-1/4"	45"	650
302-72230*	72230A	20 Tons	6-1/2" / 26-1/4"	45"	670

302-71203



302-71500



302-72212

302-72225

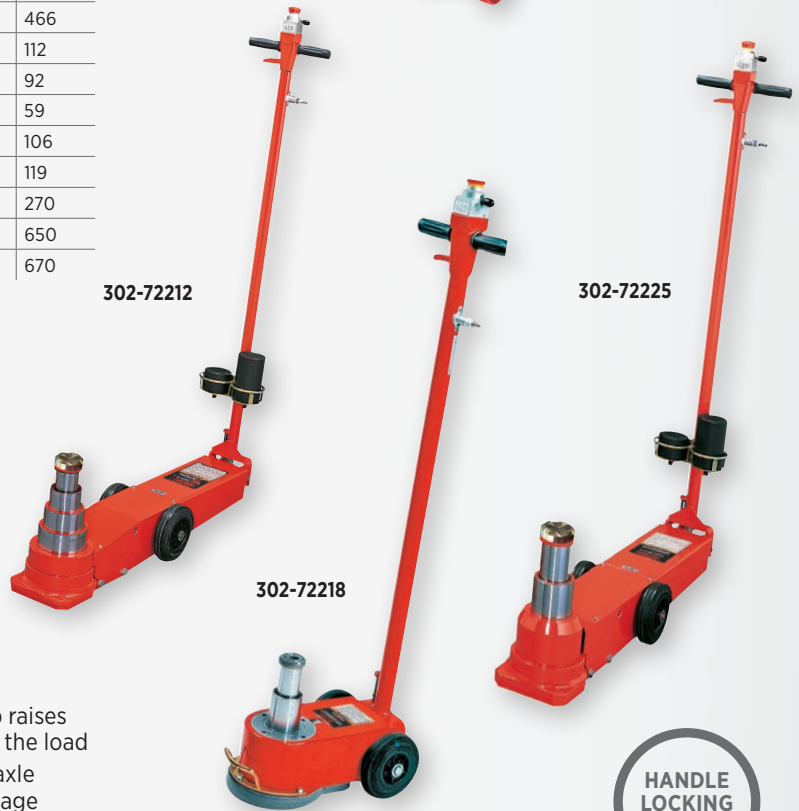

302-72218



30, 50 AND 55-TON CAPACITY AIR/HYDRAULIC TELESCOPIC FLOOR JACKS

- Long "T" handle for positioning jack under vehicles with low overhang
- Low profile
- Handle locking lever secures handle in either vertical, horizontal or 45° position
- Safety overload system prevents cylinder damage
- Rust inhibitive coating on rams
- Integrated filter protects air motor
- Double acting pump raises ram more quickly to the load
- Suspension loaded axle prevents wheel damage
- Made in Italy

Ascot No.	Mfg. No.	Capacity	Min. / Max. Height	Stroke	Chassis Size	Wheel Diam.	PSI Range	Wt. (Lb.)
302-72212	72212	55 Tons	5.9" / 15.4"	9.5"	8.6" x 39.3"	7"	100-175	233
302-72218	72218	33 Tons	5.9" / 12.71"	7.3"	8.5" x 49.2"	8-1/2"	120-175	106
302-72225	72225	50 Tons	8.7" / 16.6"	7.9"	8.6" x 39.3"	7"	120-175	235

HANDLE LOCKING LEVER

LONG T-HANDLE



YAK 2 STAGE 44/22 TON AIR HYDRAULIC HD JACK

- Air hydraulic jack for heavy vehicles, practical and easy to handle
- The pistons move back automatically; the two descent valves guarantee perfect holding in all situations and controlled speed under load
- Ideal for workshops, mobile workshops, tire repairers and bodywork shops
- Working air pressure: 116-145 PSI

Ascot No.	Mfg. No.	Capacity	Min. / Max. Hgt.	Wt. (Lb.)
302-92003	92003	44/22-Ton	5.91" / 11.82"	86 lbs.

YAK 2 STAGE 66/33 TON AIR HYDRAULIC JACK

- Air hydraulic jack for heavy vehicles, practical and effective
- The pistons move back automatically; the two descent valves guarantee perfect holding in all situations and controlled speed under load
- A complete range of jacks for all stroke and capacity requirements
- Ideal for workshops, mobile workshops, tire repairers and bodywork shops
- Working air pressure: 116-145 PSI

Ascot No.	Mfg. No.	Capacity	Min. / Max. Hgt.	Wt. (Lb.)
302-92006	92006	66/33-Ton	8.66" / 17.72"	157 lbs.

YAK 3 STAGE 66/33/17 TON AIR HYDRAULIC JACK

- Air hydraulic jacks with pistons moving back automatically.
- Specifically designed for lifting buses and all vehicles with low profile axles
- Working air pressure: 116-145 PSI

Ascot No.	Mfg. No.	Capacity	Min. / Max. Hgt.	Wt. (Lb.)
302-92007	92007	66/33/17-Ton	5.31" / 10.05"	110 lbs.



SERVICE JACKS

YAK 22/11-TON STANDARD AIR/ HYDRAULIC JACK

- Extremely light, compact and efficient
- Made up with the best materials on the market
- Models 92000 and 92001 represent the technological leading edge of our product range
- Included are 0.5" | 12.7 mm and (2) 2.35" | 60 mm Extensions
- Stroke: 6.5"
- Air Pressure: 116-145 PSI
- Min. Height: 5.5", Max. Height: 12.05"
- Weight: 38.5 Lbs.



Ascot No.	Mfg. No.	Description
302-92000	92000	22/11-Ton Standard Air Hydraulic Jack

YAK 44/22-TON AIR/ HYDRAULIC HD JACK

- Air hydraulic jack for heavy vehicles, practical and easy to handle
- The pistons move back automatically; the two descent valves guarantee perfect holding in all situations and controlled speed under load
- Ideal for workshops, mobile workshops, tire repairers and bodywork shops
- Stroke: 6"
- Air Pressure: 116-145 PSI
- Min. Height: 8.54", Max. Height: 18.38"
- Weight: 101 Lbs.



Ascot No.	Mfg. No.	Description
302-92004	92004	44/22-Ton Air/Hydraulic HD Jack

YAK 4 STAGE 88/55/28/17-TON AIR/HYDRAULIC JACK

- Air hydraulic jack for heavy vehicles, practical and effective
- The pistons move back automatically; the two descent valves guarantee perfect holding in all situations and controlled speed under load
- A complete range of jacks for all stroke and capacity requirements
- Ideal for workshops, tire repairers and bodywork shops
- Stroke: 11"
- Air Pressure: 116-145 PSI
- Min. Height: 7.09", Max. Height: 18.89"
- Weight: 170 Lbs.



Ascot No.	Mfg. No.	Description
302-92010	92010	4 Stage 88/55/28/17-Ton Air/Hydraulic Jack



AC HYDRAULIC 25/10-TON TWO-STAGE HYDRAULIC JACK

- **Versatile 2-stage air hydraulic jack for buses and trucks** • **MINIMUM HEIGHT:** 7.20" • Designed for heavy duty, intensive commercial use • Built-in safety overload valve • Hand-operated dead-man's control for optimum safety while lifting and lowering • Hard chromium plated piston rod for long life • 25-2TH model with telescopic handle increasing the reach under the vehicle to 83.58" ensuring safe and easy operation • *With 2 extensions (1.97"/ 3.94")*

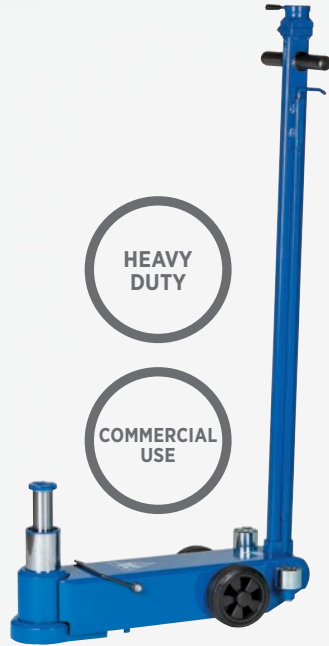

HEAVY DUTY

COMMERCIAL USE

302-00252

Ascot No.	Mfg. No.	Description
302-00252	25-2	25/10-Ton Two-Stage Hydraulic Jack

AC HYDRAULIC 50/25/10-TON THREE-STAGE HYDRAULIC JACK

- **3-stage air hydraulic jack for high clearance vehicles** • **MINIMUM HEIGHT:** 8.66" (220 mm) and **HIGH MAXIMUM HEIGHT:** 22.05" (560 mm) • Designed for heavy duty, intensive commercial use • Built-in safety overload valve • Hand-operated dead-man's control for optimum safety by lifting and lowering • Hard chromium plated piston rod for long life • 50-3HTH model with telescopic handle increasing the reach under the vehicle to 85.23" (2165 mm) ensuring safe and easy operation • *For safety reasons extensions are not included*

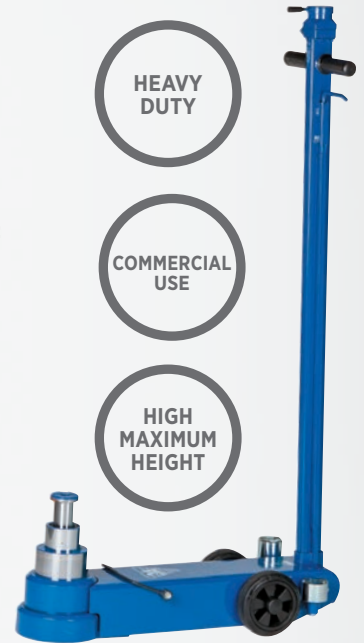

HEAVY DUTY

COMMERCIAL USE

HIGH MAXIMUM HEIGHT

302-00503

Ascot No.	Mfg. No.	Description
302-00503	50-3	50/25/10-Ton Three-Stage Hydraulic Jack

AC HYDRAULIC 50/25-TON TWO-STAGE HYDRAULIC JACK

- **2-stage air hydraulic jack for heavy buses and trucks** • **MINIMUM HEIGHT:** 8.66" (220 mm) • Designed for heavy duty, intensive commercial use • Built-in safety overload valve • Hand-operated dead-man's control for optimum safety while lifting and lowering • Hard chromium plated piston rod for long life • 50-2TH model with telescopic handle increasing the reach under the vehicle to 85.43" (2170 mm) ensuring safe and easy operation • *With 2 extensions (1.97"/ 3.94")*

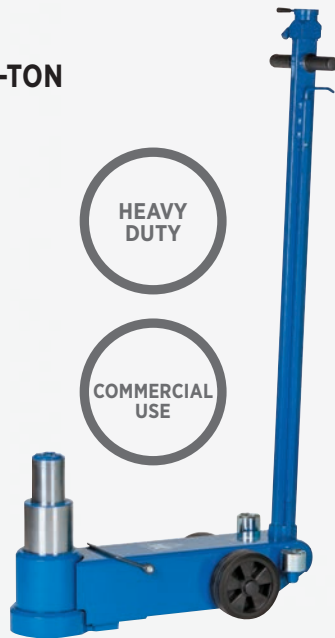

HEAVY DUTY

COMMERCIAL USE

302-00502

Ascot No.	Mfg. No.	Description
302-00502	50-2	50/25-Ton Two-Stage Hydraulic Jack

40-4 40-TON LOW PROFILE FOUR-STAGE AIR/HYDRAULIC JACK

- **The lowest jack on the market with a minimum height of only 3.94"** • Telescopic cylinders ensure a fast and safe 4-stage lift • Compact and short chassis for even the lowest vehicles • Hand-operated dead-man's control for optimum safety while lifting and lowering • Ergonomic handle with push buttons • *Includes 2 extensions (1.97/3.94 in)*

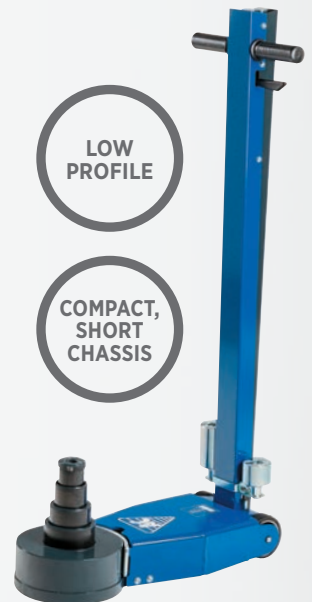

LOW PROFILE

COMPACT, SHORT CHASSIS

302-00404

Ascot No.	Mfg. No.	Description
302-00404	40-4	40-Ton Low Profile Four-Stage Air/Hydraulic Jack

SERVICE JACKS



25-TON TRUCK JACKS

- Compact, powerful design quickly lifts rated capacity
- 8-1/4" low height allows lifting from axle or suspension
- Pressure relief valve prevents overloading
- Specially coated ram prevents rust and extends jack life
- Air assisted ram retract



Includes 3" Extension

302-93735

Ascot No.	Mfg. No.	Cap. (Tons)	Min. Hgt./ Max. Hgt.	Handle Length	Base Size	Ext. Screw	Wt. (Lb.)
302-93735	HW93735A	25-Ton	8-1/4" / 21-1/2"	53"	20"x14"	5-1/8"	124



45/20-TON 2-STAGE SERVICE JACK

- Provides an even lower minimum of under 6" to get under Buses, RV's, and Car Haulers
- Built-in air regulator and water separator prolong the life of the jacks
- Solid base makes the new jack very durable and safe to operate
- Long handle and truer balance makes it easy to maneuver under a vehicle
- 3 Year Warranty

302-04532



Ascot No.	Mfg. No.	Cap. (Tons)	Min. Hgt. / Max. Hgt.	Wt. (Lb.)
302-04532	GT-4532	45/20	4-7/8" / 16-1/2"	99



TITAN 22-TON AIR/HYDRAULIC SERVICE JACK

- Air operated & easy to maneuver
- Single piece handle - will not break
- Extension saddles include: (1 of each) 1", 2" and 4"
- Operates with only 80 psi of air pressure
- Min. height: 9" (185 mm)
- Stroke Length: 6" (15 cm)
- Weight: 90 lb. (41 kg)



Ascot No.	Mfg. No.	Description
302-14140	14140	Titan 22-Ton Air/Hydraulic Service Jack

LONG CHASSIS HYDRAULIC JACKS

- Ideal for lifting heavy trucks, buses, agricultural and heavy construction equipment with hard to access lift points
- "T" handle with release knob for exact positioning of load
- Heavy gauge, sturdy frame helps prevent distortion or twisting
- Foot pedal operation provides quick, no load lifts to load point
- Long chassis for hard to reach points

Ascot No.	Mfg. No.	Capacity	Min. Hgt. / Max. Hgt.	Handle Length	Saddle Diam.	Wt. (Lbs.)
302-22050	22050C	5-Ton	7-1/4" / 27-1/4"	46"	6-1/2"	259
302-22051	22051C	5-Ton	7" / 27"	47-1/4"	5-7/8"	248
302-22100	22100C	10-Ton	6-7/8" / 27-1/2"	43"	7-1/4"	427
302-22101	22101C	10-Ton	6-3/4" / 27-1/4"	47-1/4"	7-1/4"	432
302-22201	22201	20-Ton	7-1/2" / 26"	48-1/2"	6"	543
302-93657	HW93657	4-Ton	5-1/2" / 26-1/2"	51-3/4"	7"	222
302-93667	HW93667	4-Ton	5-1/2" / 26-1/2"	51-3/4"	7"	237
302-93660	HW93660	10-Ton	6-1/2" / 25-1/2"	53"	8-1/2"	420
302-93662	HW93662	10-Ton	6-1/2" / 25-1/2"	53"	8-1/2"	430



20-TON TRUCK JACKS

- Patented "Speed Pak" provides effortless lift
- Large rubber wheels enhance mobility
- Automatic valve prevents overloading
- Extension screw permits pickup height adjustment
- **2 Year Warranty**

Ascot No.	Mfg. No.	Cap.	Min. Hgt. / Max. Hgt.	Power Raise	Handle Length	Base Size	Ext. Screw	Operating Pressure	Wt. (Lbs.)
302-93731	HW93731	20-Ton	9-3/8" / 17-5/8"	5-1/2"	50"	8" x 5-1/2"	2-1/2"	110-150 PSI	69



JACK STANDS & VEHICLE STANDS



HIGH TONNAGE JACKS

- Load blocking system • Remote control for working safely • Various extensions to suit all operations
- All models are hydro-pneumatically operated and equipped with a dual descent valve for greater control when bearing weight and automatic piston return • Can also be fitted with a manual emergency pump (on request) • Made in Italy



302-91000

HIGH TONNAGE JUMBO JACKS

- Ideal for giant tire changing, mining, railroads, construction rigging • No need for cribbing - time savings! • Balanced for easy moving • Large pneumatic wheels • Only 23" wide, the jacks fit in tight spots • 50" long, 8 position handle for easy tilt back and moving of the jack • Welded fully enclosed heavy-duty steel frame with built in lifting holes
- Hydraulic radial piston pump • Minimum 90 to 150 psi air supply needed to power hydraulic pump • Extension holders bolted to frame for easy storage • Easy to change oil filter
- All Jacks come with 5" & 9" extensions & 1" saddle
- Made in Canada

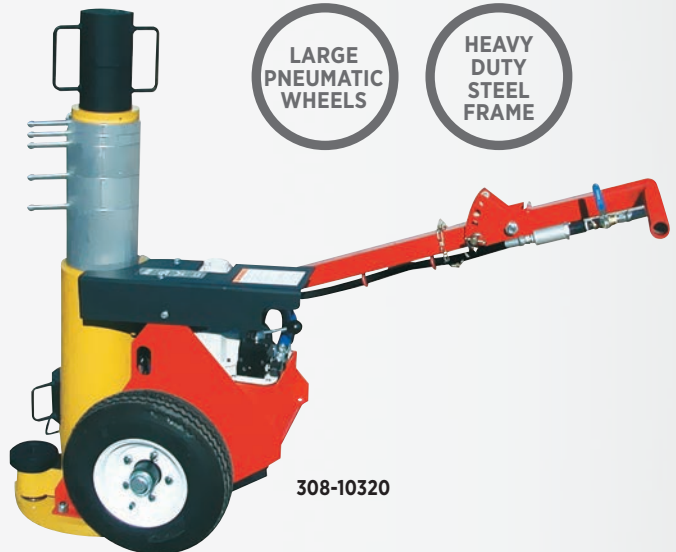

308-10320



The High Tonnage Jumbo Jack in use.

Ascot No.	Mfg. No.	Description	Capacity
302-91000	91000	High Tonnage Jack	25/50/80-Ton Stages
302-91001	91001	High Tonnage Jack	30/60-Ton Stages
302-91003	91003	High Tonnage Jack	50/80-Ton Stages
302-91004	91004	High Tonnage Jack	100-Ton
302-91005	91005	High Tonnage Jack	150-Ton

Ascot No.	Mfg. No.	Cap. (Tons)	Collapsed Point	Stroke	Lifting Height
308-10320	10320	150	27"	14-3/8"	41-3/8"
308-10321	10321	150	36"	22-3/8"	58-3/8"
308-10322	10322	100	27"	14-3/8"	41-3/8"
308-10323	10323	200	27"	14-1/2"	41-1/2"
308-10324	10324	250	27"	14"	41"



3, 6 & 12-TON JACK STANDS

• Heavy-duty jack stands that are suitable for emergency tire changes, repairs and more • Ratchet height adjustment built within column • Wide base for added stability • Multi-leveled ductile iron ratchet bar adds strength and durability • Sold in pairs of two

NOW FEATURING A DOUBLE LOCK SAFETY PIN FOR ADDED SECURITY



NOW WITH A DOUBLE LOCK PIN

WIDE BASE

10-TON HIGH JACK STANDS (PAIR)

• Pin-style stands with supporting range from 27.95" to 47.56" suitable for high-height applications

• Heavy-duty tubular steel design provides stability and rigidity • Multiple pin holes to allow easy adjustment to desired height • Saddle with lugs for easy positioning of the load • Sold and to be used only in pairs

PIN-STYLE STANDS



22-TON JACK STANDS

• Used in pairs for supporting trucks, trailers, and equipment in fleet garages, agricultural, industrial and construction environments • Sturdy, welded steel construction for exceptional safety and strength • Heavy gauge steel helps prevent distortion or twisting • Wide base for added stability • Multi-position iron column bar for convenient height adjustment • Sold in pairs of two



Ascot No.	Mfg. No.	Description
302-63221	63220-1	Support Pin for 22-Ton Jack Stands

JACK STAND SPECIFICATIONS

Ascot No.	Mfg. No.	Capacity (Tons)	Base Size	MIN. Height / MAX. Height	Shipping Weight
302-51005	510005	10	16-7/32" x 16-7/32"	27-61/64" / 47-9/16"	123.2 lb.
302-63220	63220	22	9-7/8" x 9-7/8"	13-3/8" / 19-5/8"	63.3 lb.
302-63030	63030	3-Ton	7-5/8" x 6-7/8"	11" / 16-3/8"	14.9 lb.
302-63060	63060	6-Ton	11" x 9-3/4"	15-3/4" / 24-3/8"	32 lb.
302-63120	63120	12-Ton	11-3/4" x 10-5/8"	17-1/2" / 27-1/2"	56 lb.



302-45125
12-Ton Jack Stand with Pin and Wheels

JACK STANDS & VEHICLE STANDS



12-TON JACK STAND WITH PIN AND WHEELS

- All stands have a heavy duty robot welded frame, and a multi-position ductile ratchet bar
- The quick adjustment mechanism securely locks into the right location
- Includes counter-weighted pawl for safe securing
- Capacity is per stand

Ascot No.	Mfg. No.	Cap.	Min. Hgt. / Max. Hgt.	Base Size	Wt./Pr (Lb.)
302-45125	G451205	12-Ton	11-4/5" / 18-1/10"	19"x19"	144



302-31500

302-31501

302-33020



UNDERHOIST STANDS

- Sturdy, welded steel construction for superior safety and strength
- Ideal to support the exhaust system, shock absorber and other vehicle components during an under vehicle repair - Not designed to support vehicle
- Acme screw allows for precise height adjustment

Ascot No.	Mfg. No.	Cap. (Tons)	Min. Hgt. /Max. Hgt.	Base Size	Saddle Size	Wt. (Lb.)
302-31500	31500	3/4	55" / 80"	12" Diameter	5-1/4" x 1-1/2"	33
302-31501	31501	3/4	55" / 80"	12" Diameter	5-1/4" x 1-1/2"	39
302-33020	33020	2	67" / 76-3/4"	23" x 18"	5-1/4" x 1-1/2"	53

20-TON CAPACITY TRAILER STABILIZING STANDS

- Meets OSHA requirements for supporting trailers when loaded or unloaded
- 14" diameter base provides maximum leveling stability
- Quick adjust spin handle for ease of turning
- Large diamond plate saddle to grip the load

Ascot No.	Mfg. No.	Desc.	Cap. (Tons)	Min. Hgt. / Max. Hgt.	Base Size	Saddle Size	Wt. (Lb.)
302-81022	81022A	US	20	39" / 50-5/8"	14" Diameter	4-1/2" x 5"	52
302-81122	81022Ai	Import	20	39" / 50-5/8"	14" Diameter	4-1/2" x 5"	52



302-81022

302-81034

302-81035

3/4 & 1-1/2-TON UNDER TRAILER HOIST STANDS

- Lightweight, slender design
- Quick adjust spin handle with thrust bearing eliminates wear and provides ease of turning load
- Foot pedal (81034A only) generates 1" additional stroke and 400 lb. of force at the saddle
- Pedal may be locked in vertical position for storage or shipment
- 1-1/4" diameter acme threaded screw has 26-1/4" travel

Ascot No.	Mfg. No.	Cap. (Tons)	Min. Hgt. / Max. Hgt.	Base Size	Saddle Size	Wt. (Lb.)
302-81033	81033A	3/4	55-1/4" / 81-1/2"	12" Diameter	1-5/8" x 5-1/4"	35
302-81034	81034A	3/4	55-1/4" / 81-1/2"	12" Diameter	1-5/8" x 5-1/4"	39
302-81035	81035A	1-1/2	48-7/8" / 85-3/8"	12"x12"x12"	3-1/4" x 3-1/4"	39.5

OMEGA LIFT

3, 6 AND 12-TON CAPACITY "RATCHET STYLE" STANDS

- Counter-weighted pawl serves as a safe, secure locking device to prevent the load from accidentally disengaging
- Sturdy, welded steel construction for superior safety and strength
- One piece, multi-position ductile ratchet bar provides super strength and durability, and quick adjustment mechanism that securely lock into desired location
- Sold and to be used only in pairs
- Capacity is per pair

Ascot No.	Mfg. No.	Capacity	Min. Hgt. / Max. Hgt.	Saddle Size	Base Size	Wt. (Lb.)
302-32035	32035B	3 Tons	11-384" / 17-1/4"	3-1/4" x 1-3/8"	7-3/4" x 6-3/4"	16
302-32065	32065B	6 Tons	10-1/2" / 24-1/8"	4" x 1-1/4"	10-1/8" x 9-1/2"	33
302-32125	32125B	12 Tons	17-3/4" / 27-5/8"	4" x 1-1/2"	10-3/4" x 12"	61



302-32035

OMEGA LIFT

7, 10 AND 22-TON CAPACITY PIN-STYLE JACK STANDS

- Sturdy, welded steel construction for superior safety and strength
- Heavy gauge, steel frame helps prevent distortion or twisting
- Sold and to be used only in pairs
- Capacity is per pair

Ascot No.	Mfg. No.	Capacity	Min. Hgt. / Max. Hgt.	Saddle Size	Base Size	Wt./Pr (Lb.)
302-32075	32075B	7 Tons	9-1/2" / 12-1/4"	3-1/2" x 2-3/8"	8-1/2" x 8-1/2"	22
302-32105	32105B	10 Tons	18-5/8" / 31-1/8"	3-1/8" x 5"	16-1/8" x 15-5/8"	84
302-32107	32107B	10 Tons	28" / 47-5/8"	3-3/8" x 5"	16-1/4" x 46-1/4"	109
302-32225	32225B	22 Tons	12" / 19-5/8"	3-1/8" x 2-3/4"	9-7/8" / 9-7/8"	66



302-32225



25-TON CAPACITY JACK STANDS

- Intended for fleet and maintenance garages where low profile stands are used to support loaded trailers
- Pin-type support column adjusts to four different height positions
- Adjustment pin is secured to stand to prevent loss
- Handle provides ease of positioning and carrying
- 3/8" thick solid steel base plate for stability

Ascot No.	Mfg. No.	Desc.	Capacity	Min. / Max Hgt.	Hgt. Intervals	Saddle Size	Base Size	Wt. (Lb.)
302-81225	81225	US	25 Tons	12" / 20"	3" x 3"	2-1/4" x 3-1/4"	10" x 10"	65
302-82225	81225i	Import	25 Tons	12" / 20"	3" x 3"	2-1/4" x 3-1/4"	10" x 10"	65



302-81225



20-TON SCREW STYLE JACK STAND

- Screw-style stand makes it easy to hold load at desired height and secure with locking collar
- Adjustable screw for height extension and retraction
- Heavy duty design and application

Ascot No.	Mfg. No.	Cap. (Tons)	Min. Hgt. / Max. Hgt.	Base Thickness	Base Size	Wt. (Lb.)
302-10802	10802	20	16.5" x 26.5"	1/4"	13" x 13"	65
302-10803	10803	20	26" x 46"	1/4"	13" x 13"	82



302-10803



JACK STANDS & VEHICLE STANDS



3 AND 6-TON JACK STANDS

- Saddle column provides ratchet action height adjustment
- Dual purpose handle serves as carry handle and saddle column release
- Multi position ratchet bar provides strength and durability
- Formed base adds stability and helps reduce sinkage into pavement



Ascot No.	Mfg. No.	Cap. (Tons)	Min. Hgt. / Max. Hgt.	Height Intervals	Saddle Size	Base Size	WT. (Lb.)
302-93503	HW93503	3	12-1/8" / 19"	5/8"	7-1/2" x 9"	1" x 4-1/2"	18.5
302-93506	HW93506	6	16-1/4" / 25-3/4"	5/8"	10-1/2" x 13"	1" x 5"	41

7-TON FORKLIFT STAND

- Low profile muscle work for forklifts and heavy machinery
- Wide, square base for maximum load stability
- Adjusts from 9-1/2" to 15-3/4" at 1" intervals
- Heavy duty holding pins for adjustable heights
- Lightweight for portability and ease of positioning



Ascot No.	Mfg. No.	Cap. (Tons)	Min. Hgt. / Max. Hgt.	Height Intervals	Saddle Size	Base Size	WT. (Lb.)
302-93524	HW93524A	7	9-1/2" / 15-3/4"	1"	2-1/2" x 4-1/2"	7-1/2" x 7-1/2"	36

10-TON PIN-STYLE JACK STAND

- Ideal for fleet, agricultural and construction maintenance
- Pin style column adjusts in 2" height intervals
- Heavy duty square tubing
- Large saddle securely supports load
- Sold in pairs
- Capacity is per pair



Ascot No.	Mfg. No.	Cap. (Tons)	Min. Hgt. / Max. Hgt.	Base Size	WT. (Lb.)
302-93511	HW93511	10	30" / 52"	19" x 19"	148

10-TON JACK STANDS

- Ideal for fleet, agricultural and construction maintenance
- Heavy duty pin style height adjustment
- Wide, square tubing construction and base for maximum load stability
- Adjusts from 19-1/2" to 31-1/2" in 2" intervals
- Large saddle secures load
- Integrated carrying handle
- Sold and to be used in pairs
- Capacity is per pair



Ascot No.	Mfg. No.	Cap. (Tons)	Min. Hgt. / Max. Hgt.	Base Size	WT. (Lb.)
302-93512	HW93512	10	20" / 31-1/2"	16" x 16"	90



3, 6, 10, 12 & 25-TON CAPACITY JACK STANDS



3, 6, 10, 12 & 25-TON CAPACITY JACK STANDS

- Unique spring loaded pawl provides constant locking pressure against lifting column when raising the column to the load - the benefit is that it makes it a one-handed operation
- Four legged base with foot pads for added strength and more secure footing
- Common machine bolt secures lifting column to stand and provides stability
- Recessed column saddle for acceptance of vehicle panel rail
- Design qualification tested to 200% of rated capacity
- Capacity is per pair

Ascot No.	Mfg. No.	Cap. (Tons)	Min. Hgt. / Max. Hgt.	HT. Intervals	Saddle Size	Base Size	Wt./Pr (Lb.)
DOMESTIC							
302-81205	81205	5	9-1/2" / 15-3/4"	3" x 2"	3" x 4-1/2"	9" x 9"	38
302-81208	81208	10	10-1/2" / 17"	4" x 1-1/2"	3" x 5"	12-1/2" x 12-1/2"	60
302-81209	81209	10	18-1/2" / 30"	7" x 1-1/2"	3" x 5"	17" x 17"	80
302-81210	81210	10	28" / 47"	10" x 2"	3" x 5"	16" x 16"	106
302-81225	81225	25	12" / 20"	3" x 3"	2-1/4" x 3-1/4"	10" x 10"	65
IMPORT							
302-81004	81004C	3	12" / 17-1/2"	9/16"	1-1/8" x 4-9/16"	7-1/2" x 7-7/8"	19
302-81006	81006D	6	16-1/4" / 24-7/8"	5/8"	1-1/8" x 4-7/8"	10-1/16" x 11-1/16"	30
302-81012	81012	12	19-5/8" / 29-3/8"	1-1/4"	1-5/8" x 4-3/4"	13" x 15"	86
302-82205	81205i	5	9-1/2" / 15-3/4"	3" x 2"	3" x 4-1/2"	9" x 9"	38
302-82208	81208i	10	10-1/2" / 17"	4" x 1-1/2"	3" x 5"	12-1/2" x 12-1/2"	60
302-82209	81209i	10	18-1/2" / 30"	7" x 1-1/2"	3" x 5"	17" x 17"	80
302-82210	81210i	10	28" / 47"	10" x 2"	3" x 5"	16" x 16"	106
302-82225	81225i	25	12" / 20"	3" x 3"	2-1/4" x 3-1/4"	10" x 10"	65

6 AND 12-TON MAGIC LIFT™ JACK STANDS



6 AND 12-TON MAGIC LIFT™ JACK STANDS

- Innovative design of Magic Lift offers a fast lift for professional performance
- Rack bar quickly raises to desired support point
- Heavy gauge, steel frame helps prevent distortion and twisting
- Counter-weighted pawl locks ratchet bar securely in place
- Capacity is per pair



Ascot No.	Mfg. No.	Cap.	Min. Hgt. / Max. Hgt.	Base Size	Wt./Pr (Lbs.)
302-32066	32066	6-Ton	15-3/4" / 25"	11" x 10"	34
302-32126	32126	12-Ton	15-1/2" / 24-1/4"	14-3/4" x 12-3/4"	77



TRANSMISSION & SPECIALTY JACKS



9-TON CAPACITY JACK STANDS

- Ideal for Forklift Trucks
- Sturdy, welded steel construction
- Heavy gauge steel frame prevents distortion or twisting
- Sold in pairs

Ascot No.	Mfg. No.	Cap. (Tons)	Min. Hgt. / Max. Hgt.	Wt. (Lb.)
302-14360	14360	9	9-1/2" / 16-1/2"	25



302-14360

20-TON CAPACITY HEAVY DUTY JACK STANDS

- Sturdy, welded steel construction for superior safety and strength
- Heavy gauge, steel frame helps prevent distortion or twisting
- Sold in pairs
- Capacity is per pair

Ascot No.	Mfg. No.	Cap. (Tons)	Min. Hgt. / Max. Hgt.	Wt. (Lb.)
302-14400	14400	20 per pair	12" / 20"	72



302-14400

40-TON ADJUSTABLE JACK STANDS

- 3 lock pin settings for adjustable heights
- Certified to 150% of stated capacity
- Adjustable Swivel allows for 2" of variance at locked settings
- Sold in pairs
- Capacity: 20 tons per stand

Ascot No.	Mfg. No.	Cap. (Tons)	Min. Hgt. / Max. Hgt.
302-14405	14405	40 per pair	10" / 21.9"



302-14405



25-TON HEAVY DUTY JACK STAND

- Ideal for fleet, agricultural, and construction maintenance
- Pin style column adjusts in 1-1/2" height intervals
- Heavy duty square tubing
- Large saddle securely supports load
- Sold in pairs

Ascot No.	Mfg. No.	Cap. (Tons)	Min. Hgt. / Max. Hgt.	Height Intervals	Base Size	Wt. (Lb.)
302-93526	HW93526F	25	12-3/8" / 20-3/8"	2-1/8"	10" x 10"	90



302-93526



371-72000
1-1/2-Ton
Capacity Truck
Transmission
Jacks

1-1/2-TON CAPACITY TRUCK TRANSMISSION JACKS

- For heavy truck transmissions
- Fully adjustable universal saddle with adjustable arms to position the transmission
- Heavy duty chain with convenient chain tensioner secures load to saddle
- Safety bypass system prevents damage to the hydraulic cylinder
- Norco manufactures over 20 vehicle and service specific adapters to enhance the capabilities of their transmission jacks



Ascot No.	Mfg. No.	Capacity	Min. Hgt./ Max. Hgt.	Wheel Diam.	Chassis Size	Saddle Size	Wt. (Lbs.)
DOMESTIC							
371-72000	72000E	1-1/2-Ton	7-3/4" / 36-1/2"	4"	25" / 45"	10-1/4" / 11"	310
IMPORT							
371-72001	72000Ei	1-1/2-Ton	7-3/4" / 35-2/4"	4"	26-1/2" / 44-1/2"	10-1/4" / 15-1/4"	302



371-72701
1-Ton Capacity Hydraulic
Transmission Jack

1-TON CAPACITY HYDRAULIC TRANSMISSION JACK

- Designed for the removal, installation and transportation (in the lowered position) of heavy duty truck transmissions that are raised by an above-ground lift
- Air/hydraulic foot pump for hands free operation
- Fully adjustable universal saddle with adjustable arms
- Heavy duty chain with chain tensioner to secure load to saddle
- Made in Taiwan



Ascot No.	Mfg. No.	Capacity	Min. Height	Max. Height	Wt. (Lbs.)
371-72701	72701	1 Ton	41-1/4"	69-3/8"	273

TRANSMISSION & SPECIALTY JACKS



TRANSMISSION JACK & FUEL TANK REMOVER ADAPTERS

- Allows for a safer and quicker removal of transmissions that are not flat on the bottom
- Adapters fit transmission jacks 72050E, 72500E and 72550B

Ascot No.	Mfg. No.	Description
309-72501	72501B	Adapter for use on GMC 4-Wheel Drive Transmission Case. WEIGHT: 18 lb.
309-72502	72502B	Adapter for use on 4 and 5 Speed Truck Transmissions. WEIGHT: 13 lb.
309-72504	72504B	Adapter for use on GMC Front Wheel Drive Transmissions. WEIGHT: 24 lb.
309-72505	72505B	Adapter for use on GMC Front Wheel Drive Transmissions (X, J and A Bodies) 3T40. WEIGHT: 15 lb.
309-72506	72506B	Adapter for use on GMC 440 Metric Transmissions 4T60-E. WEIGHT: 11-1/2 lb.
309-72507	72507A	Adapter for use on Ford 640E & 4R100 (4WD) Truck & Van Transmissions
309-72508	72508	Fuel Tank Adapter
309-72517	72507B	Adapter for use on Ford E40D Truck Transmissions. WEIGHT: 34 lb.
309-72525	72525	Optional saddle that replaces the four Adjustable Corner Brackets found on Standard and Universal Saddles
309-72533	72533	This tool will allow for the safe and secure removal and installation of DPFs, Drive Shafts, and automotive transmissions up to 750lb. The bean bag eliminates the need for individual DPF transmission adapters.



371-72533

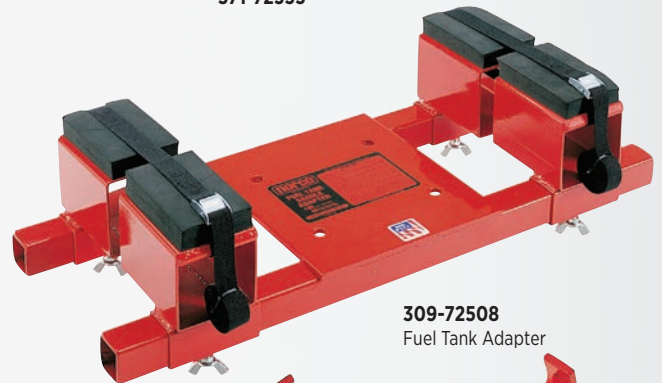

309-72508 Fuel Tank Adapter



309-72525 Optional Saddle



1-TON FLOOR STYLE TRANSMISSION JACK

- Wishbone design allows unit more mobility
- Wide stance tubular steel frame equipped with a 4 ball bearing 360° swivel casters
- Built in relief valves prevent overloading
- Two heavy cast adjustable mounting plates and load restraint chain
- **2 Year Warranty**



Ascot No.	Mfg. No.	Cap. (Tons)	Min. Hgt. / Max. Hgt.	Chassis Size	Forward Tilt/ Rear Tilt	Sideway Tilt	Wt. (Lb.)
371-93718	HW93718	1	10-1/4" / 45-1/4"	47-1/2" / 28-1/4"	27-11/16° / 32°	13° L & R	309



371-93718 1-Ton Floor Style Transmission Jack



371-93720
Telescopic
Transmission Jack



LOAD
RETENTION
PIN

FULLY AIR
OPERATED



TELESCOPIC TRANSMISSION JACK

- First stage utilizes air for a quick initial rise
- Second stage uses hydraulic hand pump for precise control
- Four ratcheting brackets fit transmission pan flanges
- Hefty nylon safety strap helps anchor transmission
- Wide spread casters for smooth maneuverability
- Head adjustments made easy with big easy-to-grip crank handles
- *Optional adapters available*
- **2 Year Warranty**

Ascot No.	Mfg. No.	Cap. (Tons)	Min. Hgt. / Max. Hgt.	Lifting Head Hgt.	Chassis Size	Forward Tilt/Rear Tilt	Sideway Tilt	Wt. (Lb.)
371-93720	HW93720	1/2	34"-1/2" / 72"	11-3/8" x 11-3/8"	41-1/4" / 41-1/4"	50° / 20°	11° L & R	117



TELESCOPIC TRANSMISSION JACK

- Chrome-plated rams maximize its high reach operated by a user friendly foot pedal
- Extra-wide base lowers center of gravity and promotes stability
- Rugged steel wheels and full swivel ball bearing casters
- Adjustable ratchet style saddle (Model 41000C and 41001C)
- A unique release pedal provides safety in lowering the load
- Model 41000C and 41001C are 2 stage manual
- Model 41001C is Air Actuated and requires 110-175 PSI

CHROME
PLATED
RAMS



371-41000
Telescopic
Transmission Jack

Ascot No.	Mfg. No.	Cap. (Tons)	Min. Hgt. / Max. Hgt.	Saddle Base	Min. Exp. Saddle Area	Max. Exp. Saddle Area	Jack Size	Wt. (Lb.)
371-41000	41000C	1/2	39-22/25" / 77-1/4"	12-5/8" x 7-7/8"	12-5/8" x 7-7/8"	21" x 21"	33-13/100" x 35-1/2"	161
371-41001	41001C	1/2	39-7/8" / 77-1/4"	11-1/2" x 11-1/2"	11-1/2" x 11-1/2"	21" x 21"	33-13/100" x 35-1/2"	171
371-42003	42003	1	46" / 74-3/4"	13 x 13	13 x 13	24-1/2" x 19"	42" x 39-3/4"	294

FLOOR-STYLE TELESCOPIC TRANSMISSION JACK

- The adjustable head can be tilted forward, backward and side to side for optimum alignment of transmission bolt pattern and pins
- Hydraulic system is protected from internal damage by a patented by-pass mechanism
- Load-restraining chain is vital for raising and lowering safety
- Four wheel casters allow easy movement and positioning of transmission jack
- Rugged steel wheels and full swivel ball bearing casters
- User friendly 360° rotating pumping socket for maximum in directional operation

FULLY
ADJUSTABLE
HEAD



371-43000

Ascot No.	Mfg. No.	Cap. (Tons)	Min. Hgt. / Max. Hgt.	Saddle Base	Handle Length	Exp. Saddle Area	Jack Size	Wt. (Lb.)
371-42000	42000C	1	7-3/4" / 33"	14-3/4" x 7-7/8"	22-1/2"	17" x 15-1/2"	39-3/8" x 19-1/8"	200
371-43000	43000	1-1/2	7-7/8" / 37-1/4"	14-3/4" x 16-1/8"	29-1/2"	16-1/8" x 26-7/8"	46-3/4" x 25-5/8"	376

TRANSMISSION & SPECIALTY JACKS



FULLER ROAD RANGER TRANSMISSION ADAPTER FOR HW93718

- Fuller Transmission Kit for HW93718

Ascot No.	Mfg. No.	Description
309-93248	HW93248	Fuller Road Ranger Transmission Adapter for HW93718

309-93248
Fuller Road Ranger
Transmission
Adapter for
HW93718



FUEL TANK ADAPTER FOR OMEGALIFT AND HEIN-WERNER TRANSMISSION JACKS

- Specifically designed to enable the telescopic transmission jack to be used in the removal and installation of fuel tanks
- Maximum tank size of 40 gallons
- Two (2x) ratcheting nylon safety straps
- Four (4x) padded arms to avoid damage on metal tank

Ascot No.	Mfg. No.	Description
309-40080	40080	Fuel Tank Adapter for OmegaLift and Hein-Werner Transmission Jacks

309-40080
Fuel Tank Adapter

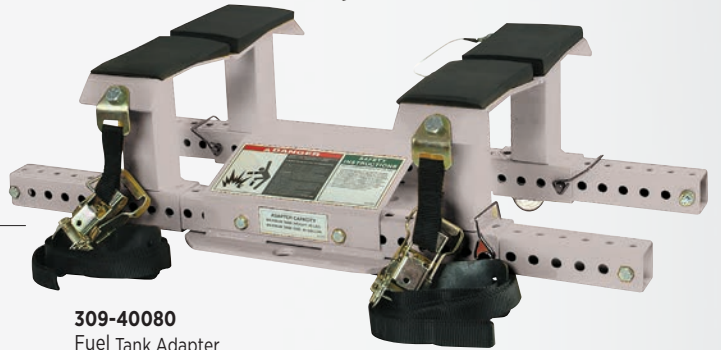

HEIN-WERNER MULTIPURPOSE TRANSMISSION ADAPTER

- Optional, for use with HW93720

Ascot No.	Mfg. No.	Description
309-93721	HW93721	Hein-Werner - Multipurpose Transmission Adapter

309-93721
Hein-Werner Multipurpose
Transmission Adapter

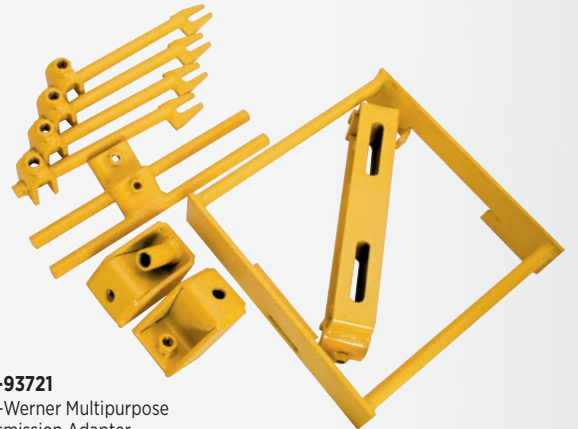

20-TON TRUCK RAMPS

- Specifically designed for heavy-duty tasks
- 33" Long T-handle increases mobile efficiency
- Sold in sets of two only



Ascot No.	Mfg. No.	Cap. (Tons)	Frame Size	Wheel Diam.	Handle Length	WT. (Lb.)
302-93200	93200	20	13-1/2" x 45"	5"	33-3/4"	267

302-93200
20-Ton Truck Ramp



**HEIN-WERNER
AUTOMOTIVE**

**10-TON AIR OPERATED
WHEEL LIFT SYSTEM**

- Lifts engage wheels without needing to remove panels on vehicle
- Raise front or rear end of vehicle using a single controller
- Load retention pin allows lifts to function as stands in six different positions
- Completely air operated
- 2 Year Warranty
- Sold in pairs



308-93693
10-Ton Air Operated
Wheel Lift System

Ascot No.	Mfg. No.	Cap. (Tons)	Min. Hgt. / Max. Hgt.	Power Raise	Wheel Diam. MIN./MAX.	Frame Size (W x D x H)	PSI	WT. (Lb.)
308-93693	HW93693	10	Floor Level / 24"	24"	19-1/2" / 24-1/2"	41-9/16" x 44-1/4" x 53-1/4"	160	1,234

**HEIN-WERNER
AUTOMOTIVE**

10-TON CAPACITY LIFT JACKS

- Doubles as a support stand
- HW93737A has a removable handle and 10 foot air hose for safe position and operation
- Completely air-operated
- 2 Year Warranty



308-93737
10-Ton Capacity
Lift Jack

308-93690
10-Ton Capacity
Lift Jack

Ascot No.	Mfg. No.	Cap. (Tons)	Min. Hgt. / Max. Hgt.	Power Raise	Saddle Spread	Lifting to front Saddle Distance	Height Intervals	Min. PSI for Rated Load	WT. (Lb.)
308-93690	HW93690	10	17-3/4" / 40"	28"	28" to 53"	13"	N/A	200	670
308-93737	93737A	10	17" / 52-1/2"	11-1/2"	N/A	N/A	2-1/2"	200	165

TRANSMISSION & SPECIALTY JACKS



OMEGALIFT

HD PIN
LOCKING
SYSTEM

FULLY AIR
OPERAT-

10-TON AIR JACK AND SUPPORT STAND

- Operates as both a support stand and air actuated jack
- Completely air operated and has a heavy duty pin locking system
- Comes with a 10 foot air hose and maneuverable wheel base for easy accurate positioning
- A total lift range of 17-1/2" to 51" makes it a very versatile and helpful piece of equipment

Ascot No.	Mfg. No.	Cap. (Tons)	Min. Hgt. / Max. Hgt.	Hydraulic Height	Base Size	Wt. (Lb.)
308-34100	34100	10 Ton	17-1/2" / 51-1/8"	11-1/2"	22" X 12"	189



308-34100
10-Ton Air Jack and Support Stand

10 AND 15-TON CAPACITY PORTABLE AIR LIFT JACKS

- Designed for use in garages/repair shops of truck, farm equipment, construction equipment and bus companies
- Ideal for crowded conditions that require single point contact
- Three-way heavy duty air valve provides fine control when lifting or lowering a load
- Extension tubes and detent pins offer multiple lifting heights
- Unit easily maneuvered on two 8" diameter rubber tread wheels
- Removable handle and 8' air hose for remote safe positioning and operation
- Lifting saddle with serrated surface and locating lugs
- May be used in pairs

308-82990
10-Ton Capacity Portable Air Lift Jack



Ascot No.	Mfg. No.	Cap. (Tons)	Min. Hgt. / Max. Hgt.	Overall Length	Overall Width	Overall Height	Stroke	Wt. (Lb.)
308-82990	82990C	10	17-3/4" / 49-3/8"	58"	13-5/8"	17-3/4"	11-1/2"	178
308-82992	82992	15	18-1/8" / 51-3/8"	59-1/2"	15"	18-1/8"	11-1/4"	279

3-WAY
HEAVY
DUTY AIR
VALVE



10-TON CAPACITY AIR LIFT JACK

- Designed for use in truck and farm equipment dealer garages, heavy duty construction repair shops and bus company garages
- Three-way heavy duty air valve provides fine control when lifting or lowering a vehicle
- Automatic safety lock engages in six different height positions independent of air pressure
- Designed for lifting entire front or rear of a vehicle
- Front swivel caster wheel and two 12-1/4" diameter pneumatic rear tires provide easy maneuverability
- Adjustable lifting saddles can be raised and extended to desired position



308-82999
10-Ton Capacity
Air Lift Jack



Ascot No.	Mfg. No.	Cap.	Min. Hgt. / Max. Hgt.	Min. PSI for Rated Load	Wt. (Lbs.)
308-82999	82999	10-Ton	12-1/2" / 50"	200	817
308-83999	83999i	10-Ton	12-1/4" / 49-1/2"	200	817



4-TON CAPACITY FORKLIFT JACK

- Two-position saddle at scissors end can be quickly rotated to handle either edges or flat surfaces of a load
- 2-1/4" low lift height at scissors end
- 30" removable handle for ease of pumping and storage when not in use
- Our "fingertip control" release knob provides slow, controlled, lowering of the load
- Safety bypass and overload systems prevent cylinder damage and prevent the jack from being used beyond the ASME/PASE load-limiting standard



TWO POSITION SADDLE AT SCISSORS END



Lifts at edge



Lifts flat surfaces

302-72036
4-Ton Capacity
Forklift Jack



Ascot No.	Mfg. No.	Cap. (Tons)	Min. Hgt. / Max. Hgt.	Overall Length	Overall Width	Wt. (Lb.)
302-72036	72036D	4	2-1/4" / 16-1/4"	26-1/8"	8-3/4"	75

TRANSMISSION & SPECIALTY JACKS



OMEGALIFT

4-TON CAPACITY FORKLIFT JACK

- **DUAL LIFT POINTS FOR VARIOUS LIFTING APPLICATIONS:** The lower point is for forklift truck lifts and the higher point is for most farm equipment lifts
- Precision control of lifting and lowering functions



Ascot No.	Mfg. No.	Cap. (Tons)	Min. Hgt. / Max. Hgt.	Wt. (Lb.)
302-28045	28045	4	3" / 17-1/2"	91

302-28045
4-Ton Capacity Forklift Jack



HEIN-WERNER
AUTOMOTIVE

4-TON FLOOR FORKLIFT JACK

- Specially designed seals and strong steel construction
- Low pick-up height
- Removable handle and compact size
- **2 Year Warranty**



Ascot No.	Mfg. No.	Cap. (Tons)	Min. Hgt./ Max. Hgt.	Power Raise	Handle Length	Base Size	Wt. (Lb.)
302-93659	HW93659	4	2-1/2" / 16-1/2"	14"	25"	8" x 26-1/2"	71

302-93659
4-Ton Floor Forklift Jack





1/2-TON CAPACITY HYDRAULIC WHEEL DOLLY

- For the removal and installation of single, tandem and duplex tires and wheels which are mounted on trucks that are supported above ground level
- Heavy duty lift arms made with ball bearing conveyor rollers allow easy rotation of wheels for alignment with bolt pattern
- 7-1/2" of side-to-side lift arm adjustment eliminates the trial and error method of aligning the rim's lug holes with the wheel drum
- A 1500-pound capacity heavy duty winch with 5-to-1 gear ratio provides ease of operation
- The winch gear design acts as a brake and allow the load to be lowered incrementally if desired and without the need of constant hand pressure against the crank handle
- A hydraulic jack tilts the lift arms in order to match the angle of the spindle
- Safety chain provided to secure tires and wheels to the dolly
- Maneuverability is made easy by means of two rear mounted ball bearing swivel caster wheels. The caster wheels include a locking mechanism which can prevent the dolly from moving
- Perfect for use with truck lifts
- ASSEMBLED in the USA
- 82304 has the same great features as the 82302B but also includes and air-operated pump that allows the unit to lift the load effortlessly



407-82302



407-82304



WHEEL DOLLY SPECIFICATIONS

Ascot No.	Mfg. No.	Cap. (Tons)	Lift Range	Tilt Range	Lift Arm Size	Side to Side Adj.	Product Size (W x D x H)	Wt. (Lb.)
407-82302	82302B	1/2	3" - 41-1/4"	-2°-30°	24-1/4" x 21"	3-1/4" (Left), 4-1/4" (right)	45-3/4" x 43-3/4" x 62"	315
407-82304	82304	1/2	2-1/8" - 39-1/2"	-2°-30°	30-7/8" x 22-1/8"	2-1/2" (Left), 4-1/2" (right)	49-5/8" x 44-5/8" x 69-7/8"	476

WHEEL DOLLIES



HEAVY DUTY TIRE DOLLY

- Reduce back injuries
- Perfect stud alignment
- Perfect for 8 to 10-hole Budd-type wheels
- Removes truck wheels and tires quickly and easily
- Increases productivity
- Reduces manpower needs
- Saves time and money, maintenance free
- Works with tires 23.5" to 43.5"



Ascot No.	Mfg. No.	Description
407-03000	BJ-T300A	Heavy Duty Tire Dolly

Ascot No.	Mfg. No.	Description
AVAILABLE ACCESSORIES FOR HEAVY DUTY TIRE DOLLY		
407-10400	104	Roller Sets for Heavy Duty Tire Dolly
407-11100	111	Rubber Wheel for Heavy Duty Tire Dolly
407-11200	112	Deep Groove Ball Bearing for Heavy Duty Tire Dolly
407-11600	116	Pin Lock for Heavy Duty Tire Dolly
407-11900	119	Rubber Cover for Heavy Duty Tire Dolly
407-12000	120	Nylon Wheel for Heavy Duty Tire Dolly



TW2000 TWEEL HANDLER™

- The TW2000 solution is a built-in ratcheting jack with 14° of vertical travel
- The Tweel Handler's U-shaped chassis allows you to get close to the work area, with unhindered access to the tire in the cradle
- No restraining chains are required, yet the Tweel Handler™ holds virtually any single truck wheel, including wide-based singles
- Three heavy-duty ball-bearing wheels mounted under ball-bearing swivel casters make it highly maneuverable



Ascot No.	Mfg. No.	Description
407-02000	TW2000	TW2000 Tweel Handler™



SAFER-GO TRUCK TIRE DOLLY

- This convenient dolly makes manually lifting wheel sets completely unnecessary
- Simply slide the rollers underneath the tire and use the jack handle to raise it to the desired height
- Use the included Gaither O-LINE-ER® to perfectly position the wheel for easy installation
- Equipped with a collapsible handle frame making it easy to store and ideal for mobile service
- LIFTING CAPACITY: 350 lbs.



Ascot No.	Mfg. No.	Description
407-47110	G471106	Safer-Go Truck Tire Dolly



407-70130
Truck Wheel Dolly

FAST AND EASY

HEAVY DUTY STEEL

EASY GRIP HANDLE

407-82312
26" Narrow Single Tire Handler Dolly

407-82310
22" Narrow Single Tire Handler Dolly

STEEL FRAME

LONGER ROLLERS

O-LINE-ER included

407-47105
Winntec Tire Dolly



TRUCK WHEEL DOLLY

- Tire/wheel is rotated left or right on tilttable roller pads for perfect stud alignment
- Perfect for 8-10 hole Budd type wheels
- Removes truck wheels and tires fast and easy
- Increases productivity
- Reduces manpower needs
- Saves time and money, maintenance free
- Heavy duty tubular construction lifts 280 lbs.
- 3" caster wheels roll the truck wheels for effortless removal or replacement

Ascot No.	Mfg. No.	Description
407-70130	70130	TRUCK: 8" Rollers (280 lbs. capacity)
407-70132	70132	SUPER SINGLE: 14" Rollers (450 lbs. capacity)



TIRE DOLLIES

- Heavy-duty tubular steel construction capable of handling 300 pounds
- Easy grip handle along with improved "bent arm" design improves leverage for easier installation and minimizes back strain
- Steel alignment rollers for simple alignment of the wheel to the wheel studs
- Spring-loaded kickstand offers convenient storage
- Can accommodate tire diameters from 36" to 48"

Ascot No.	Mfg. No.	Description
407-82310	82310	22" Narrow Single Tire Handler Dolly
407-82312	82312	26" Wide Single Tire Handler Dolly



WINNTEC TIRE DOLLY

- 500 lb. capacity allows for use on all commercial truck tire sizes
- Steel frame is more durable than Aluminum units
- Longer rollers (2-1/2" longer) makes it even easier to handle super single sizes
- Wheel position allows tech to lift tire/wheel assembly by pushing down, instead of lifting up
- O-LINE-ER and Bracket included with new production models (O-LINE-ER used for lining up stud holes with studs)

Ascot No.	Mfg. No.	Description
407-47105	G471105HD	Winntec Tire Dolly

WHEEL DOLLIES

FOUR SWIVEL CASTER WHEELS

AIR-OPERATED CONTROLS



407-82306



300 LB. CAPACITY SINGLE TIRE LIFTER

- To safely assist a technician with the removal and installation of single wheels on vehicles that are supported on a lift
- Maneuverability is made easy by means of four swivel caster wheels
- Two rear caster wheels include a locking mechanism which can prevent the dolly from moving
- Unique offset design offers open access from the rear to mount wheel to the vehicle
- Onboard rollers make for easy stud-to-hole alignment
- Air-operated controls allows the unit to lift the load effortlessly
- 4" low height of support legs

Ascot No.	Mfg. No.	Cap.	Lift Travel	Min. Hgt. / Max. Hgt.	Width	Length	Wt. (Lbs.)
407-82306	82306	300 Lbs.	35-1/8"	4" / 39-1/8"	9" - 22"	17-1/2" - 33-1/4"	200

WIDE FRAME & LIFTING CARRIAGE



HANDY TOOL/PARTS TRAY



407-93766



3/4-TON WHEEL DOLLY

- For handling of dual wheels and large single wheels
- Designed to facilitate the removal and installation of pneumatic tires and wheel assemblies found on many trucks, buses and trailers
- Handles up to 52" diameter tires and wheels
- The frame is constructed from heavy gauge welded square tubular steel for maximum strength and durability
- Load levelers aid alignment
- Carriage arm rollers with self-lubricating bearings
- Restraining chain with the unit to secure the load
- 2 swivel ball bearing casters for easy positioning
- Wide frame and lifting carriage
- Handy tool/parts tray on frame
- The wheel dolly is designed to be used in conjunction with jacks and jacks stands
- 2 Year Warranty

Ascot No.	Mfg. No.	Cap. (Tons)	Lift Range	Arm length/Spread	Overall Size (W x D x H)	Wt. (Lb.)
407-93766	HW93766	3/4	4" - 9"	23" / 26-1/2"	39-1/2" x 38-3/4" x 32"	118

HYDRAULIC SYSTEM

CHAIN FOR LOAD RESTRAINT



407-47050



3/4-TON WHEEL DOLLY

- Hydraulic system actuated to provide smooth, positive power for the removal and installation of single, tandem, and duplex tires and wheels
- Lift arms can be adjusted to handle different wheel combinations
- Tilt range of -2 degrees to -5 degrees
- Width of 43" for large loads
- Load restraining chain for security

Ascot No.	Mfg. No.	Cap. (Tons)	Lift Range	Tilt Range	Lift Arm Size	Product Size (W x D x H)	Wt. (Lb.)
407-47050	47050C	3/4	2-1/2" - 8-3/8"	2°-5°	25-7/8" x 25-1/4"	45-1/8" x 39-1/2" x 34-7/8"	222



3/4-TON WHEEL DOLLY

- Dolly handles any tire diameter and up to 1500 lb. combined tire and wheel weight
- Three 4" diameter swivel ball bearing caster wheels provide easy maneuverability and positioning
- Travel adjustment on rear locking caster wheel matches lifting arms with spindle angle
- 6' chain included to secure wheel assembly to dolly during removal and transport
- Quick disconnect push/pull handle provides unobstructed access to hub area
- Assembled in the USA

Ascot No.	Mfg. No.	Cap. (Tons)	Lift Travel	Lift Arm Size	Product Size (W x D x H)	Wt. (Lb.)
407-82320	82320	3/4	4-3/4"	26" x 24-1/2"	43-1/2" x 39-1/2" x 35"	175



3/4-TON WHEEL DOLLY

- Hydraulic system actuated to provide smooth, positive power for the removal and installation of single, tandem, and duplex tires and wheels
- Load restraining chain for security

Ascot No.	Mfg. No.	Cap. (Tons)	Lift Range	Tilt Range	Lift Arm Size	Product Size (W x D x H)	Wt. (Lb.)
407-47053	47053	3/4	2-1/4" - 11"	(-)2 - 5°	25-7/8" x 25-1/4"	43-1/2" x 43" x 34-7/8"	151



WHEEL DOLLY FOR AGRICULTURAL AND EARTH MOVING MACHINERY



- Easy and safe mounting, demounting and handling of large wheels on agricultural and earth moving machinery
- Capable of handling large wheels from 45.3" up to 84.7" in diameter and up to 41.3" in depth
- CAPACITY: 3,306 lbs
- Double acting hydraulic system
- Hands-free switch between lifting and lowering action
- Safe and controlled lowering
- 2 x 4 large rollers improve handling of tires with deep treads
- Top-point wheel connection rod keeps the wheel in safe balance

Ascot No.	Mfg. No.	Description
407-90538	90538	Wheel Dolly for Agricultural and Earth Moving Machinery

HYDRAULIC SHOP PRESSES & SHOP EQUIPMENT



50 AND 100-TON CAPACITY HYDRAULIC SHOP PRESSES

• **For heavy duty use in truck garages and industrial work shops**

- Manually operated two speed pump provides quick ram travel to load
- Hand operated winch raises and lowers press bed
- Welded frames for strength and no assembly required
- Self-retracting ram is bearing mounted for lateral movement on head channel
- **Delivered Fully Assembled**
- **Assembled in the USA**
- 78057A features air/hydraulic foot pump and 10' hose
- 78058A and 78110B feature electro/hydraulic pump

FOR
HEAVY
DUTY
USE

QUICK RAM
TRAVEL
TO LOAD

317-78058
50-Ton Capacity
Hydraulic
Shop Press



Ascot No.	Mfg. No.	Operating System	Cap. (Tons)	Ram Travel	Min. Hgt. / Max. Hgt.	Throat Width	Bed Height ADJ.	Between Uprights	Between Bed Rails	Wt. (Lb.)
317-78055	78055A	Manual	50	6-1/4"	7-1/2" / 32-5/8"	34-1/2"	7 x 5"	5-5/8"	7-3/8"	804
317-78057	78057A	Air/Hydraulic	50	6-1/4"	7-1/2" / 32-5/8"	34-1/2"	7 x 5"	5-5/8"	7-3/8"	801
317-78058	78058A	Electro/Hydraulic	50	6-1/4"	7-1/2" / 32-5/8"	34-1/2"	7 x 5"	5-5/8"	7-3/8"	814
317-78077	78077	Air/Hydraulic	50	13-1/4"	7-1/2" / 32-5/8"	34-1/2"	7 x 5"	5-5/8"	7-3/8"	833
317-78078	78078	Electro/Hydraulic	50	13-1/4"	7-1/2" / 32-5/8"	34-1/2"	7 x 5"	5-5/8"	7-3/8"	846
317-78110	78110B	Electro/Hydraulic	100	10-1/4"	18-1/4" / 45-3/4"	40-1/4"	8 x 4-1/2"	5-5/8"	9"	1,777

ARBOR PLATES (FOR USE WITH NORCO 12 AND 20-TON SHOP PRESSES)

- For use with Norco 12 and 20-ton shop presses only
- 1" x 4" x 10" long steel plates with "V" cutout on one edge and circle cutout on the other



317-78000

Ascot No.	Mfg. No.	Description
317-78000	78000	12 and 20-ton capacity pair of Arbor Plates. WEIGHT: 20 lb.

ARBOR PLATES (FOR USE WITH NORCO 50 AND 100-TON SHOP PRESSES)

- For use with Norco 50 and 100-ton shop presses only

Ascot No.	Mfg. No.	Description
317-78056	78056A	50-ton capacity pair of Arbor Plates. WEIGHT: 108 lb.
317-78111	78111A	100-ton capacity pair of Arbor Plates. WEIGHT: 153 lb.

HYDRAULIC GAUGE WITH FITTING

- For use with Norco 12 and 20-ton capacity shop presses only
- 4" diameter face
- Dial indicates internal pressure (PSI) and corresponding pounds of force at ram end
- Accurate within 2-1/2%
- 1/4" NPT fitting

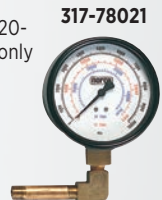

317-78021

Ascot No.	Mfg. No.	Description
317-78021	78021	Hydraulic Gauge with Fitting. WEIGHT: 2 lb.

25-TON CAPACITY HYDRAULIC SHOP PRESS

- Excellent for bending, bonding or straightening applications
- Multi-position bed for work height adjustment
- Heavy steel welded construction
- Includes hand winch for easy bed adjustments
- Ideal for the removal or installation of gears, universal joints, pulleys, wrist pins, and other press jobs
- 4" pressure gauge

55-TON CAPACITY HYDRAULIC SHOP PRESS

- Excellent for bending, bonding or straightening applications; Ideal for the removal or installation of gears, universal joints, pulleys, wrist pins, and other press jobs
- Heavy steel welded construction
- Pressure relief valve for overload protection
- Dual stage release control valve
- Multi-position bed for work height adjustment

100-TON CAPACITY HYDRAULIC SHOP PRESS

- Excellent for bending, bonding or straightening applications
- 100-Ton Capacity
- Heavy steel welded construction
- Includes hand wench for easy bed adjustments
- 1 HP / 2-gallon electric pump
- Quiet operation meets OSHA regulations
- Industrial hard chrome-plated ram helps prevent rust and corrosion
- Ideal for the removal or installation of gears, universal joints, pulleys, wrist pins, and other press jobs

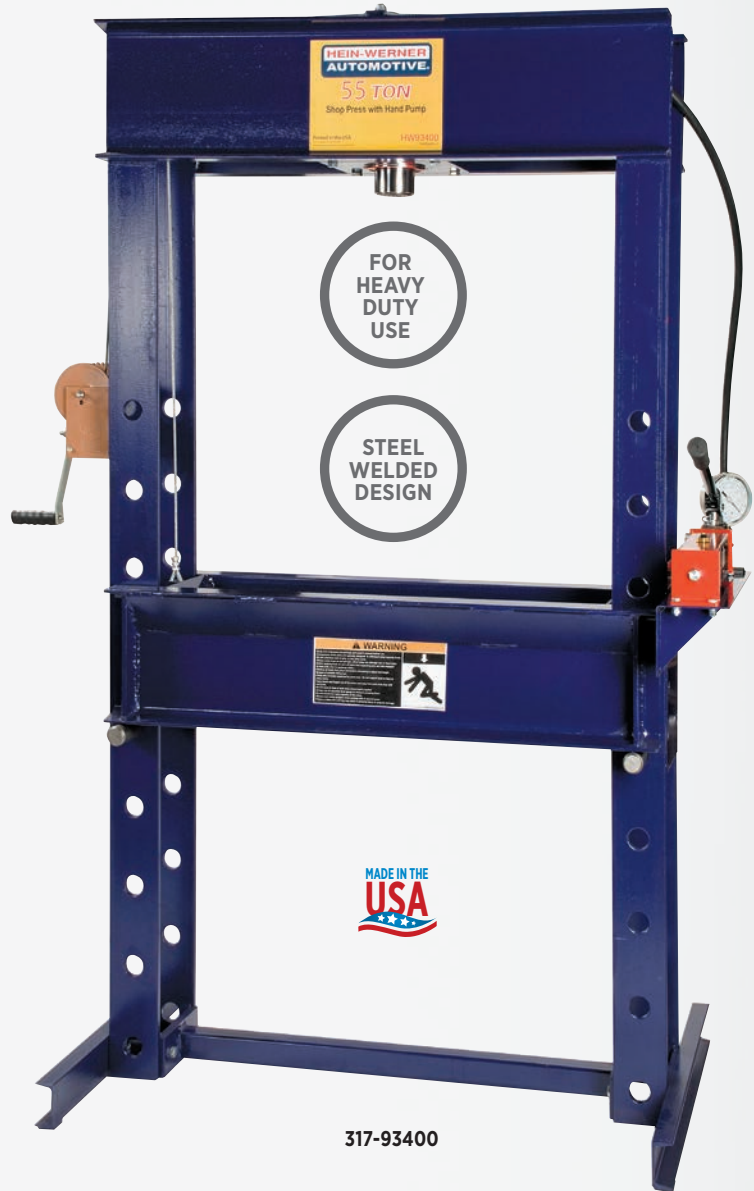

317-93400

SHOP PRESS SPECIFICATIONS

Ascot No.	Mfg. No.	Description	Capacity (Tons)	Stroke	Interior Width	Type of Pump	Working Height	Bed Positions	Shipping Weight (lb.)
317-93300	HW93300	25-Ton Shop Press with Manual Hand Pump	25	6"	30"	Hand Pump	6-1/2" - 49-1/2"	8	484
317-93400	HW93400	55-Ton Shop Press with Manual Pump	55	6"	35-1/2"	Air Pump	7-1/2" - 55-1/2"	9	855
317-93610	HW93610	100-Ton Shop Press with Electric Pump	100	10"	35-3/8"	Electric Pump	12-1/4" - 52-1/2"	6	1221

BRAKE DRUM HANDLERS



BRAKE DRUM HANDLER

- Designed for removing and installing and transporting outboard mounted brake drums and inboard mounted drums with disc wheel hubs • Reduces lost-time injuries • Handles 15" and 16-1/2" drums • Machine rotating handle provides ease of raising and lowering drum • Ball bearing wheels, semi-pneumatic tires and 3/4" diameter axle provide easy maneuverability and balance of the drum • Adjustable angle bracket secures both outboard and inboard mounted drums with disc wheel hubs to the drum handler's carriage • Detachable handle for convenient storage

FOUR ADJUSTABLE LEGS

FOR HEAVY LOADS



407-72040

Ascot No.	Mfg. No.	Low Lift Height	High Lift Height	Overall Size	Wheel Diameter	Wt. (Lb.)
407-72040	72040B	10-1/4"	15-1/4"	21" / 62-1/2"	8"	64



BRAKE DRUM HANDLER

- Ideal for removing and installing truck brake drums • Works with 15" and 16-1/2" drums • Includes detachable handle for convenient storage

DETACHABLE HANDLE

FOR TRUCK BRAKE DRUMS



407-46000

Ascot No.	Mfg. No.	Description
407-46000	46000	Brake Drum Handler

BACK BUDDY II

- The 350B Back Buddy II™ will make brake jobs easier and more profitable • This versatile tool was designed to prevent injuries from awkward lifting and keep workers' comp rates down • The Back Buddy II™ rolls under and bolts onto heavy drum and hub assembly, then handily rolls the assembly out and lays it over for servicing • Re-assembly is quick and precise because the Back Buddy II™ angles for perfect hub alignment, eliminating seal damage and costly fixes • The Back Buddy II™ handles all hub and drum assemblies with Universal Receiver and Adapter Sets • A simple change of adapters transforms the tool in seconds from inboard to outboard application • Adapters 6069 and 6073 10-hole inboard and outboard application are included • Other wheel adapters sold separately

REASSEMBLY IS QUICK & PRECISE



407-00350

Ascot No.	Mfg. No.	Description
407-00350	350B	Back Buddy II



DIESEL ENGINE STAND

- Rotating even a 6,000 lb. diesel engine is easy; a 96:1 ratio worm and gear set does the job
- The crank handle can be locked in any position
- Integral 12-ton jack raises the work to provide the swing radius needed for clearance
- Two front wheels and two rear casters provide mobility
- Universal adapter assembly permits use with a wide variety of mounting plates for Caterpillar, Cummins, Mack, IH, and Detroit in-line or "V" series diesel engines, as well as Allison transmissions
- **COVERED BY OTC LIFETIME MARATHON WARRANTY***



331-01750
Diesel Engine Stand

Ascot No.	Mfg. No.	Description
331-01750	1750A	Diesel Engine Stand

TRUCK CLUTCH/FLYWHEEL HANDLER

- Replaces 14" and 15-1/2" clutch assemblies
- Swivel casters provide easy maneuverability
- Lifting range of 9" to 37"
- **CARRIES A LIFETIME MARATHON WARRANTY***



331-05015
Truck Clutch/
Flywheel Handler

Ascot No.	Mfg. No.	Description
331-05015	5015A	Truck Clutch/Flywheel Handler

HD CLUTCH ADJUSTING WRENCH

- Used for the internal adjustment of Spicer angle-spring and multiple-lever clutches



372-07028
HD Clutch
Adjusting Wrench

Ascot No.	Mfg. No.	Description
372-07028	7028	HD Clutch Adjusting Wrench

HYDRAULIC JACK OIL

- **Formulated with oxidation stable base oils, rust inhibitors, antiwear agents & antifoam agents to provide protection for hydraulic jacks and lifting equipment**
- 32 oz. bottle • 6 bottles per case



309-00925



Ascot No.	Mfg. No.	Description
309-00925	MAG-925	Hydraulic Jack Oil (6 per Case)

HYDRAULIC JACK OIL

309-93294



309-93291

Ascot No.	Mfg. No.	Description
309-93291	HW93291	Hydraulic Jack Oil - 1 Quart
309-93294	HW93294	Hydraulic Jack Oil - 1 Gallon

TIRE & WHEEL SERVICE ACCESSORIES



TUBE BRUSHES

- For internal cleaning and deburring of copper tube fittings

Ascot No.	Mfg. No.	Length	Brush Length	Dia.	Fill Wire	Trim Length
535-14168	14168	6-1/2"	1"	5/8"	Steel	—
535-14169	14169	6-1/2"	1"	1/2"	Steel	—
535-14180	14180	6-1/2"	1"	3/4"	Steel	—
535-14166	14166	8"	2"	1/2"	Steel	0.004



535-14166

535-14168

535-14169

SCRATCH BRUSH

- 7 rows of steel bristles
- Ridged handle for better grip
- Common applications include cleaning dirt, rust, scale, chips and paint as well as plating and welding operations

Ascot No.	Mfg. No.	Size	Width/Face	Rows	Fill Wire	Wire Dia.	Trim Length
535-14159	14159	7-1/2"	7-1/2"	3x7	Stainless Steel	0.006"	7-1/2"



535-14159

MISCELLANEOUS TIRE SWABS AND BRUSHES

Ascot No.	Mfg. No.	Description
437-00001	TS-1	Tire Swab - 11" OAL X 2" Diameter
437-00002	TS-2	Tire Swab - 15" OAL X 2" Diameter
437-00003	TS-3	Tire Swab - 18" OAL X 3" Diameter
437-40006	40006	Tire Lubricating Brush
437-13014	313014	Hunter-Style Tire Lubricating Brush



437-00001

437-00002

437-00003



437-40006



437-13014

TIRE LUBRICANTS & SEALANTS



SLICK

- Contains rust inhibitor to prevent rusting of rims
- Tire adheres to rim. Will not slip
- Helps to seal tire bead. Reduces bead damage
- Will not gum up the bead or rim to hinder its future use
- Reduces friction. Saves wear and repair on tire changers
- Contains no soap or petroleum products

Ascot No.	Mfg. No.	Description
432-57304	55073-4	(4) 1-Gallon Bottles
432-57305	55073-5	5-Gallon Pail
432-57355	55073-55	55-Gallon Drum
432-57270	55073-270	275-Gallon Tote



ASCOT TIRE AND TUBE MOUNTING COMPOUND

- Versatile formula-dilutes to any strength your job requires
- Approved by major tire companies world-wide • Made from natural, renewable resources • Totally safe for all tires • Economical when diluted
- Ultra-thick concentrate for excellent performance when packing beads



Ascot No.	Mfg. No.	Description
432-02028	2028	Tire/Tube Mounting Compound, 8 lb. Pail (4 per Case)
432-02029	2029	Tire/Tube Mounting Compound, 25 lb. Pail
432-02035	2035	Tire/Tube Mounting Compound, 40 lb. Pail

ASCOT BLACK TIRE LUBRICANT

- Stops the bonding or "freezing" of tire beads to tire rims which allows for easy, damage free removal of tires • Will not swell or affect rubber, especially inner tubes • Contains no petroleum



Ascot No.	Mfg. No.	Description
435-02785	2785	Ascot Black Tire Lubricant, 8 lb. Pail (4 per Case)
435-02786	2786	Ascot Black Tire Lubricant, 25 lb. Pail

BLACK RIM RUST RETARDANT & TIRE LUBE

- Makes tire mounting and dismounting faster and easier • Now with rust inhibitor • Approved by major rubber companies
- Lubricates all rubber parts, stops rubber squeaks



Ascot No.	Mfg. No.	Description
435-06001	065-2539	Black Rim Rust Retardant Tire Lube, 6 - 5 lb.
435-06008	048-2539	Black Rim Rust Retardant Tire Lube, 4 - 8 lb.
435-06002	025-2539	Black Rim Rust Retardant Tire Lube, 25 lb.
435-06003	040-2539	Black Rim Rust Retardant Tire Lube, 40 lb.
435-06004	120-2539	Black Rim Rust Retardant Tire Lube, 120 lb.
435-07001	041-2541	Tire Mounting & Rubber Lubricant, 4 Gal.
435-07002	005-2541	Tire Mounting & Rubber Lubricant, 5 Gal.
435-08001	025-2540	Tire Mounting & Rubber Lubricant Paste, 25 lb.
435-08002	048-2540	Tire Mounting & Rubber Lubricant Paste, 8 lb.
435-08003	040-2540	Tire Mounting & Rubber Lubricant Paste, 40 lb.



TIRE LUBRICANTS & SEALANTS



MURPHY'S CONCENTRATED TIRE & TUBE MOUNTING COMPOUND

- Versatile formula-dilutes to any strength your job requires
- Approved by major tire companies world-wide
- Made from natural, renewable resources
- Totally safe for all tires
- Economical when diluted
- Ultra-thick concentrate for excellent performance when packing beads



432-02005



Ascot No.	Mfg. No.	Description
432-02000	2000	Murphy's Concentrated Tire & Tube Mounting Compound, 8 lb. Pail (4 per Case)
432-02005	2005	Murphy's Concentrated Tire & Tube Mounting Compound, 25 lb. Pail
432-02008	2008	Murphy's Concentrated Tire & Tube Mounting Compound, 40 lb. Pail
432-02014	2014	Murphy's Concentrated Tire & Tube Mounting Compound, 445 lb. Drum

MURPHY'S WHITE TIRE MOUNTING EURO PASTE

- Designed for alloy wheels, low profile and run flat tires
- Extra Slippery to help mount tires with stiff beads
- No water, no mixing. Use right from the container
- Contains rust inhibitor to help fight rim rust



432-02167



Ascot No.	Mfg. No.	Description
432-02146	2146	8 lb. Pail
432-02167	2167	8 lb. Pail (Low Profile)

MURPHY'S NON-RUST RIM-KOTE

- Acts as tire mounting lubricant - prevents tire bead "freezing"
- Contains no petroleum - prevents rim rust and scale
- Great for seating tubeless bias, belted and radial tires
- APPLICATIONS: Recommended for mounting tires on heavy duty trucks, buses and off-the-road vehicles



Ascot No.	Mfg. No.	Description
434-02110	2110	Non-Rust Rim-Kote, 25 lb. Pail
434-02120	2120	Non-Rust Rim-Kote, 40 lb. Pail



MURPHY'S SLIX BLACK LUBE

- Stops the bonding or "freezing" of tire beads to tire rims which allows for easy, damage free removal of tires
- Will not swell or affect rubber, especially inner tubes
- Contains no petroleum



435-02085

Ascot No.	Mfg. No.	Description
435-02086	2086	Murphy's Slix Black Lube, 8 lb. Pail (4 per Case)
435-02085	2085	Murphy's Slix Black Lube, 25 lb. Pail



NO RIM RUST

- Protects tires. Tire bead won't fuse to rim
- Helps prevent corrosion on rims and rigs
- Helps you comply with OSHA Regulation 3086



435-00125

Ascot No.	Mfg. No.	Description
435-00015	FL4-1	No Rim Rust, 4-1/2 lb. Pail
435-00125	FL25-1	No Rim Rust, 25 lb. Pail
435-01120	FL120-1	No Rim Rust, 120 lb. Drum



MURPHY'S LIQUID LUBRICANT

- Designed to assist in mounting rubber tires and tubes on all types of wheels
- Ready to use liquid for easy application
- Easy clean up and non-toxic • Contains rust inhibitor to help fight rust



433-02020

Ascot No.	Mfg. No.	Description
433-02020	2020	Murphy's Liquid Lubricant, 1 Gallon (4 per Case)
433-02023	2023	Murphy's Liquid Lubricant, 5 Gallons
433-02022	2022	Murphy's Liquid Lubricant, 55 Gallons

MURPHY'S CONCENTRATED EXTRA SLIPPERY LIQUID LUBRICANT

- Contains improved super lubricity polymers
- Rust inhibitor added to help fight rim rust
- **ECONOMICAL:** Dilutes 2 to 1 • Formulated for super-fast mount of passenger tires



433-01950

Ascot No.	Mfg. No.	Description
433-01950	1950	Murphy's Concentrated Extra Slippery Liquid Lubricant, 1 Gallon (4 per Case)
433-01957	1957	Murphy's Concentrated Extra Slippery Liquid Lubricant, 5 Gallons
433-01958	1958	Murphy's Concentrated Extra Slippery Liquid Lubricant, 55 Gallons

UNIVERSAL MOUNTING PASTE



- Makes mounting and demounting tires easier and faster and helps alleviate stress on and damage to the bead area of tires • Tire mounting paste applies with a sponge and will not corrode or discolor aluminum or alloy wheels, won't freeze or harden • Rubber Lubricant is a liquid concentrate that makes one gallon of rust-inhibiting water-based mounting lubricant



432-00751



437-00730

432-00740

432-00750

432-01750

Ascot No.	Mfg. No.	Description	Qty./Box
432-00730	73	Mounting Paste Brush for Car/Light Truck	1
432-00731	73T	Mounting Paste Brush for Trucks	1
432-00740	74	Universal Mounting Paste, 22 lb.	1
432-00750	75	High Profile Universal Mounting Paste, 7.7 lb.	1
432-01750	75N	Low Profile Universal Mounting Paste, 7.7 lb.	1
432-00751	75B	Bracket For Mounting Paste	1
437-00001	TS-1	Swab - 11" OAL x 2" Diameter	1
437-00002	TS-2	Swab - 15" OAL x 2" Diameter	1
437-00003	TS-3	Swab - 18" OAL x 3" Diameter	2

OTR MOUNTING/PACKING COMPOUND

- Extra thick for Superior Bead Packing on OTR tires • Makes OTR Tire Mounting Faster and Easier
- Will not separate or liquefy



432-12490

Ascot No.	Mfg. No.	Description
432-12490	2490	OTR Mounting/Packing Compound, 25 lb.
432-12492	2492	OTR Mounting/Packing Compound, 40 lb.



TIRE LUBRICANTS & SEALANTS



TIRE MOUNTING COMPOUNDS

- **Excellent Lubrication** • Will not separate or liquefy • Superior for tire bead packing
- Concentrated; water soluble, can be diluted



432-12180



432-12280

Ascot No.	Mfg. No.	Description
432-12178	2178	Tire Mounting Compound (Honey Color), 8 lb. (4 per Case)
432-12180	2180X	Tire Mounting Compound (Honey Color), 25 lb.
432-12183	2183	Tire Mounting Compound (Honey Color), 40 lb.
432-12012	2012	Tire Mounting Compound (Honey Color), 125 lb.
432-12014	2014	Tire Mounting Compound (Honey Color), 55 Gal.
432-12278	2278	Tire Mounting Compound (Brown Color), 8 lb. (4 per Case)
432-12280	2280	Tire Mounting Compound (Brown Color), 25 lb.
432-12282	2282	Tire Mounting Compound (Brown Color), 40 lb.
432-12214	2214	Tire Mounting Compound (Brown Color), 55 Gal.

LIQUID LUBE BLUE TIRE MOUNTING LIQUID

- **Excellent Lubrication** • **Superior “Tack” and Bead Sealing qualities** • Reduces tire/rim slippage • Concentrated; water soluble, can be diluted • Near neutral pH factor



433-81505



433-81511

433-81515

Ascot No.	Mfg. No.	Description
33-8150	81505	Liquid Lube Blue Tire Mounting Liquid, 2 Gal. (5 Gal. Mixing Pail)
433-81511	81511	Liquid Lube Blue Tire Mounting Liquid, 1 Gal. (4 per Case)
433-81515	81515	Liquid Lube Blue Tire Mounting Liquid, 5 Gal.
433-81555	81555	Liquid Lube Blue Tire Mounting Liquid, 55 Gal.

BEAD BUTTER BLUE TIRE MOUNTING LIQUID LUBE

- **Excellent Lubrication**
- No Residue
- Concentrated; water soluble, can be diluted



433-02054

433-02053

Ascot No.	Mfg. No.	Description
433-02053	2053B	Bead Butter Blue Tire Mounting Liquid Lube, 1 Gal. (4 per Case)
433-02054	2054B	Bead Butter Blue Tire Mounting Liquid Lube, 5 Gal.
433-02055	2055B	Bead Butter Blue Tire Mounting Liquid Lube, 55 Gal.

BLACK-ICE STOP RUST RIM RELEASE

- **Lubricates rim and tire for easy mounting & demounting**
- Protects against rust & corrosion • Prevents rim and bead from bonding



435-02480

Ascot No.	Mfg. No.	Description
435-02480	2480	Black-Ice Stop Rust Rim Release, 25 lb. Pail

SURE SHOT PRESSURE SPRAYERS

- Air pressurized and refillable
- Environmentally safe, eliminates aerosol usage
- For brake and parts cleaner, penetrating oils, lubricants, degreasers, solvents
- **MADE IN USA**



632-01002

Ascot No.	Mfg. No.	Description
632-00005	K-5	Partial Repair Kit for Model A Sure Shot Sprayers
632-00010	K-10	Complete Repair Kit for Model A Sure Shot Sprayers
632-01002	A1002	Sure Shot Black Enamelled Steel Sprayer w/ Adjustable Nozzle
632-10001	A1000R	Sure Shot Enamelled Steel Sprayer - Red

INDUSTRIAL SPRAY BOTTLE - QUART SIZE

- Industrial sprayer for use with light oils, solvents, and detergents
- The durable polyethylene bottle is impervious to high and low temperatures
- The trigger mechanism is resistant to damage caused by caustic materials



632-00923

Ascot No.	Mfg. No.	Description
632-00923	3210B32	Industrial Spray Bottle - 32 Oz. Capacity

ANODIZED ALUMINUM SPRAYER

- Adjustable pistol-grip nozzle
- Features a chemical resistant anodized finish
- Will work with water, solvent & oil-based materials
- Replaces Model "A" plated brass sprayers
- 24 oz. capacity
- **MAX PRESSURE: 200 PSI**
- **MADE IN USA**



632-02400

Ascot No.	Mfg. No.	Description
632-02400	M2400S	Anodized Aluminum Sprayer

EZ CHECK LEAK DETECTOR

- Finds leaks in all tires
- Environmentally friendly
- Excellent foam formation
- Skin friendly
- Commercial use only

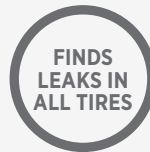

455-25430

455-25431

Ascot No.	Mfg. No.	Description
433-25430	2543	Ascot EZ Check Leak Detector, Quart (12 per case)
433-25431	2543-1G	Ascot EZ Check Leak Detector, Gallon (4 per case)



INDUSTRIAL SPRAY BOTTLE - PINT SIZE

Ascot No.	Mfg. No.	Description
632-00922	TS-922	16 Oz. Poly Trigger Sprayer



632-00922



TIRE LUBRICANTS & SEALANTS



PB B'LASTER PENETRANT

- Quickly breaks loose the surface tension of frozen parts and protects against further corrosion
- Powerful concentrated penetrating catalyst
- Non-evaporating lubricant
- Protects against further rust and corrosion
- 11 oz. aerosol can
- **QUANTITY:** 12 cans per case

Ascot No.	Mfg. No.	Description
408-00016	16PB	B'laster Penetrant, 11 oz. Can (12 per case)



408-00016



E-Z BREAK® ANTI-SEIZE COMPOUND-COPPER GRADE

- Copper-based anti-seize and lubricating compound
- Prevents seizing of aluminum wheels to steel brake drums or rotors
- Will not wash off in rain or snow
- Other applications include head bolts, exhaust manifolds and muffler connections, brackets and engine bolts
- Withstands temperatures to 1800°F (982°C)

Ascot No.	Mfg. No.	Description
494-01010	08910	10 Oz. Can With Brush in Cap
494-08907	08907	16 Oz. Can with Brush in Cap
494-08916	08916	14 Oz. Aerosol Can



494-08916



LIQUITUBE

- Effective for tire life. Seals ALL sources of air-loss
- Helps balance truck tires
- Helps maintain proper air pressure
- Keeps tires cooler for increased tread wear
- Does NOT rust or corrode wheels
- Water soluble for easy clean out for recapping tire casings

Ascot No.	Mfg. No.	Description
451-00640	1220-0640	LiquiTube 5-Gallon Pail
451-20516	1220-516	LiquiTube 5-Gallon Injector Pump



451-00640



451-20516



STS SEALANTS

MORE SEALING. MORE SECURITY

STS TIRE SEALANTS

- Seals 2x more punctures than the competition
- Permanently seals punctures up to 1/4" • Prevents wheel corrosion, glycol free • Non-toxic, non-flammable, non-combustible • 100% bio-degradable and water soluble • Lasts for the lifetime of the tire • Wide range of applications • Low freeze point, freeze/thaw stable

PREVENTS
WHEEL
CORROSION

FREEZE/
THAW
STABLE



STS Tire Sealants

Ascot No.	Mfg. No.	Description
STS TIRE SEALANT		
451-02416	STSC24-16	(24) 16 oz. Bottles
451-04128	STSCS4128	4 (1) Gallon Per Case
451-00640	STS640	5-Gallon Pail
451-00006	STS6G	6-Gallon Pail
451-00055	STS55G	55-Gallon Drum
451-00275	STS275T	275-Gallon Tote
STS CONCENTRATE TIRE SEALANT		
451-14128	STSCONCS4128	4 (1) Gallon Per Case
451-01640	STSCON640	5-Gallon Pail
451-00026	STSCON6G	6-Gallon Pail
STS OTR TIRE SEALANT		
451-24128	STSOTRCS4128	4 (1) Gallon Per Case
451-02640	STSOTR640	5-Gallon Pail
451-00036	STSOTR6G	6-Gallon Pail
451-00255	STSOTR55G	55-Gallon Drum

STS TOOLS AND ACCESSORIES



Ascot No.	Mfg. No.	Description
451-00101	ST-XM-1	1 Gal. Hand Pump
451-00440	ST-XM-44	5 Gal. Hand Pump
451-00551	STXM55	55 Gal. Transfer Pump
451-00707	ST-TTS-WW	STS Display Stand
469-02311	VCR-A	Auto Valve Core Tool
469-02312	VCR-F	Farm Valve Core Tool

ECO SEAL

- 7x corrosion resistance
- Maintains non-acidic pH levels, even in high temperatures
- Permanently seals punctures up to 1/4"
- Glycol-free; prevents wheel corrosion
- Environmentally friendly formula, uses recycled rubber and 100% biodegradable ingredients • Non-toxic, non-flammable, non-combustible • Low freeze point (-10°F)



USES
RECYCLED
RUBBER

LOW
FREEZE
POINT
-10°F

Ascot No.	Mfg. No.	Description
451-05510	ST-XM55	5 Gal. EcoSeal Hand Pump
504-00005	ECO5G	5 Gal. Pail
504-00055	ECO55G	55 Gal. Drum
504-00275	ECO275G	275 Gal. Tote

MARKERS



PAINTSTIK® MARKERS

• **Real paint in stick form** • Ideal for coding tire casings • Marks are long lasting, water resistant and weather resistant • Marks will withstand vulcanizing and recap temperatures • Non-toxic, contains no lead • Marking range -50°F to 150°F (-46°C to 66°C) • **INCLUDES:** 12 sticks per box, 12 boxes per case

Ascot No.	Color	Ascot No.	Color	Ascot No.	Color
459-80220	White (Markal B)	459-80226	Green	459-80231	Gold
459-80221	Yellow (Markal B)	459-80227	Pink	459-80232	Aluminum
459-80222	Red	459-80228	Purple	459-80257	White
459-80223	Black	459-80229	Brown	459-80258	Yellow
459-80225	Blue	459-80230	Gray	459-80271	Orange

MARKAL TYRE MARQUE

• **Ideal for temporary marking of tires** • Marks easily on wet or cold surfaces • Lead-free, zinc-free marks can be painted over • **SIZE:** 1/2" X 4-5/8" • **MARKING RANGE:** -20°F to 130°F (-29°C to 24°C) • **INCLUDES:** 12 sticks per box, 12 boxes per case

Ascot No.	Mfg. No.	Color
459-54220	51420	White
459-54222	51421	Yellow

B® HEX WHITE TIRE PAINTSTIK

• **Ideal for temporary marking of tires** • Marks easily on wet or cold surfaces • **INCLUDES:** 12 sticks per box, 12 boxes per case

Ascot No.	Mfg. No.	Description
459-80250	80250	B® Hex White Tire Paintstik

PAINTSTIK® MARKER HOLDER

Ascot No.	Mfg. No.	Description
459-85100	85100	6" Push-Button Metal Holder for B-Paintstik

QUIK STIK® MINI

• Fast-drying, vibrant paint marks dry in 5 to 7 minutes • Compact plastic holder with clip cap stores easily in pocket and keeps hands and clothing clean • Marks on virtually any surface; wet, smooth, rough, or hot • Weather- and UV-resistant paint for long-lasting marks • Solid paint marker advances and retracts by turning twist-up knob • Xylene and 2-Butoxyethanol free formula to reduce health risks • **MARKING RANGE:** 0°F to 392°F (-18°C to 200°C)

Ascot No.	Mfg. No.	Description	Qty./Box
459-61126	61126	Mini Quik Stik® Marker (White)	12
459-61127	61127	Mini Quik Stik® Marker (Yellow)	12
459-61128	61128	Mini Quik Stik® Marker (Red)	12
459-61129	61129	Mini Quik Stik® Marker (Black)	12



459-54222



The White Markal Crayon in use.

459-80250



459-85100



TIRE BRANDERS & ACCESSORIES



TIRE REGROOVING TOOLS & ACCESSORIES

Ascot No.	Mfg. No.	Description
455-00003	RC414	Rubber Cut 414 Rema Regroover
455-00129	N/A	Set Screw for PS-15 Regroover
455-00401	W-1	Regroover Blades 20-Pack
455-00402	W-2	Regroover Blades 20-Pack
455-00403	W-3	Regroover Blades 20-Pack
455-00404	W-4	Regroover Blades 20-Pack
455-00405	W-5	Regroover Blades 20-Pack
455-00406	W-6	Regroover Blades 10-Pack
455-00444	No. 4 Head	Replacement Head for 125 Groover
455-04444	No. 4 Bld.	Replacement Blades for 125 Groover
455-12500	125	Heavy Duty Pistol Grip Tire Groover
455-15017	N/A	Transformer for PS-15 Regroover
455-15019	N/A	Rotative Switch for PS-15 Regroover



455-00003



The Rubber Cut 414 in use.

SERIAL NUMBER REMOVER TOOL

Ascot No.	Mfg. No.	Description
531-95001	TTHB-1	Serial Number Remover Tool
531-95002	RRB-1	12-Pack Replacement Blades

531-95001



531-95002

LETTERS AND NUMBERS FOR TIRE BRANDERS

TIRE BRANDERS & ACCESSORIES



1" Letters and Numbers



1/2" Letters and Numbers



1/4" Letters and Numbers

Ascot No.	Mfg. No.	Description
1" LETTERS & NUMBERS		
452-00001	TBINOSET	Tire Brander 1" Number Set
452-00011	TBILETSET	Tire Brander 1" Letter Set
452-00100	BI-CC-1BZ-0	Tire Brander 1" Insert: 0
452-00101	BI-CC-1BZ-1	Tire Brander 1" Insert: 1
452-00102	BI-CC-1BZ-2	Tire Brander 1" Insert: 2
452-00103	BI-CC-1BZ-3	Tire Brander 1" Insert: 3
452-00104	BI-CC-1BZ-4	Tire Brander 1" Insert: 4
452-00105	BI-CC-1BZ-5	Tire Brander 1" Insert: 5
452-00106	BI-CC-1BZ-6	Tire Brander 1" Insert: 6
452-00107	BI-CC-1BZ-7	Tire Brander 1" Insert: 7
452-00108	BI-CC-1BZ-8	Tire Brander 1" Insert: 8
452-00109	BI-CC-1BZ-9	Tire Brander 1" Insert: 9
452-00201	BI-CC-1BZ-A	Tire Brander 1" Insert: A
452-00202	BI-CC-1BZ-B	Tire Brander 1" Insert: B
452-00203	BI-CC-1BZ-C	Tire Brander 1" Insert: C
452-00204	BI-CC-1BZ-D	Tire Brander 1" Insert: D
452-00205	BI-CC-1BZ-E	Tire Brander 1" Insert: E
452-00206	BI-CC-1BZ-F	Tire Brander 1" Insert: F
452-00207	BI-CC-1BZ-G	Tire Brander 1" Insert: G
452-00208	BI-CC-1BZ-H	Tire Brander 1" Insert: H
452-00209	BI-CC-1BZ-I	Tire Brander 1" Insert: I
452-00210	BI-CC-1BZ-J	Tire Brander 1" Insert: J
452-00211	BI-CC-1BZ-K	Tire Brander 1" Insert: K
452-00212	BI-CC-1BZ-L	Tire Brander 1" Insert: L
452-00213	BI-CC-1BZ-M	Tire Brander 1" Insert: M
452-00214	BI-CC-1BZ-N	Tire Brander 1" Insert: N
452-00215	BI-CC-1BZ-O	Tire Brander 1" Insert: O
452-00216	BI-CC-1BZ-P	Tire Brander 1" Insert: P
452-00217	BI-CC-1BZ-Q	Tire Brander 1" Insert: Q
452-00218	BI-CC-1BZ-R	Tire Brander 1" Insert: R
452-00219	BI-CC-1BZ-S	Tire Brander 1" Insert: S
452-00220	BI-CC-1BZ-T	Tire Brander 1" Insert: T
452-00221	BI-CC-1BZ-U	Tire Brander 1" Insert: U
452-00222	BI-CC-1BZ-V	Tire Brander 1" Insert: V
452-00223	BI-CC-1BZ-W	Tire Brander 1" Insert: W
452-00224	BI-CC-1BZ-X	Tire Brander 1" Insert: X
452-00225	BI-CC-1BZ-Y	Tire Brander 1" Insert: Y
452-00226	BI-CC-1BZ-Z	Tire Brander 1" Insert: Z

Ascot No.	Mfg. No.	Description
1/2" LETTERS & NUMBERS		
452-00012	TBI/2NOSET	Tire Brander 1/2" Number Set
452-00112	TBI/2LETSET	Tire Brander 1/2" Letter Set
452-02100	BI-CC-1/2BR-0	Tire Brander 1/2" Insert: 0
452-02101	BI-CC-1/2BR-1	Tire Brander 1/2" Insert: 1
452-02102	BI-CC-1/2BR-2	Tire Brander 1/2" Insert: 2
452-02103	BI-CC-1/2BR-3	Tire Brander 1/2" Insert: 3
452-02104	BI-CC-1/2BR-4	Tire Brander 1/2" Insert: 4
452-02105	BI-CC-1/2BR-5	Tire Brander 1/2" Insert: 5
452-02106	BI-CC-1/2BR-6	Tire Brander 1/2" Insert: 6
452-02107	BI-CC-1/2BR-7	Tire Brander 1/2" Insert: 7
452-02108	BI-CC-1/2BR-8	Tire Brander 1/2" Insert: 8
452-02109	BI-CC-1/2BR-9	Tire Brander 1/2" Insert: 9
452-00501	BI-CC-1/2BR-A	Tire Brander 1/2" Insert: A
452-00502	BI-CC-1/2BR-B	Tire Brander 1/2" Insert: B
452-00503	BI-CC-1/2BR-C	Tire Brander 1/2" Insert: C
452-00504	BI-CC-1/2BR-D	Tire Brander 1/2" Insert: D
452-00505	BI-CC-1/2BR-E	Tire Brander 1/2" Insert: E
452-00506	BI-CC-1/2BR-F	Tire Brander 1/2" Insert: F
452-00507	BI-CC-1/2BR-G	Tire Brander 1/2" Insert: G
452-00508	BI-CC-1/2BR-H	Tire Brander 1/2" Insert: H
452-00509	BI-CC-1/2BR-I	Tire Brander 1/2" Insert: I
452-00510	BI-CC-1/2BR-J	Tire Brander 1/2" Insert: J
452-00511	BI-CC-1/2BR-K	Tire Brander 1/2" Insert: K
452-00512	BI-CC-1/2BR-L	Tire Brander 1/2" Insert: L
452-00513	BI-CC-1/2BR-M	Tire Brander 1/2" Insert: M
452-00514	BI-CC-1/2BR-N	Tire Brander 1/2" Insert: N
452-00515	BI-CC-1/2BR-O	Tire Brander 1/2" Insert: O
452-00516	BI-CC-1/2BR-P	Tire Brander 1/2" Insert: P
452-00517	BI-CC-1/2BR-Q	Tire Brander 1/2" Insert: Q
452-00518	BI-CC-1/2BR-R	Tire Brander 1/2" Insert: R
452-00519	BI-CC-1/2BR-S	Tire Brander 1/2" Insert: S
452-00520	BI-CC-1/2BR-T	Tire Brander 1/2" Insert: T
452-00521	BI-CC-1/2BR-U	Tire Brander 1/2" Insert: U
452-00522	BI-CC-1/2BR-V	Tire Brander 1/2" Insert: V
452-00523	BI-CC-1/2BR-W	Tire Brander 1/2" Insert: W
452-00524	BI-CC-1/2BR-X	Tire Brander 1/2" Insert: X
452-00525	BI-CC-1/2BR-Y	Tire Brander 1/2" Insert: Y
452-00526	BI-CC-1/2BR-Z	Tire Brander 1/2" Insert: Z

Ascot No.	Mfg. No.	Description
1/4" LETTERS & NUMBERS		
452-00014	TBI/4NOSET	Tire Brander 1/4" Number Set
452-00114	TBI/4LETSET	Tire Brander 1/4" Letter Set
452-01100	BI-CC-1/4BR-0	Tire Brander 1/4" Insert: 0
452-01101	BI-CC-1/4BR-1	Tire Brander 1/4" Insert: 1
452-01102	BI-CC-1/4BR-2	Tire Brander 1/4" Insert: 2
452-01103	BI-CC-1/4BR-3	Tire Brander 1/4" Insert: 3
452-01104	BI-CC-1/4BR-4	Tire Brander 1/4" Insert: 4
452-01105	BI-CC-1/4BR-5	Tire Brander 1/4" Insert: 5
452-01106	BI-CC-1/4BR-6	Tire Brander 1/4" Insert: 6
452-01107	BI-CC-1/4BR-7	Tire Brander 1/4" Insert: 7
452-01108	BI-CC-1/4BR-8	Tire Brander 1/4" Insert: 8
452-01109	BI-CC-1/4BR-9	Tire Brander 1/4" Insert: 9
452-00401	BI-CC-1/4BR-A	Tire Brander 1/4" Insert: A
452-00402	BI-CC-1/4BR-B	Tire Brander 1/4" Insert: B
452-00403	BI-CC-1/4BR-C	Tire Brander 1/4" Insert: C
452-00404	BI-CC-1/4BR-D	Tire Brander 1/4" Insert: D
452-00405	BI-CC-1/4BR-E	Tire Brander 1/4" Insert: E
452-00406	BI-CC-1/4BR-F	Tire Brander 1/4" Insert: F
452-00407	BI-CC-1/4BR-G	Tire Brander 1/4" Insert: G
452-00408	BI-CC-1/4BR-H	Tire Brander 1/4" Insert: H
452-00409	BI-CC-1/4BR-I	Tire Brander 1/4" Insert: I
452-00410	BI-CC-1/4BR-J	Tire Brander 1/4" Insert: J
452-00411	BI-CC-1/4BR-K	Tire Brander 1/4" Insert: K
452-00412	BI-CC-1/4BR-L	Tire Brander 1/4" Insert: L
452-00413	BI-CC-1/4BR-M	Tire Brander 1/4" Insert: M
452-00414	BI-CC-1/4BR-N	Tire Brander 1/4" Insert: N
452-00415	BI-CC-1/4BR-O	Tire Brander 1/4" Insert: O
452-00416	BI-CC-1/4BR-P	Tire Brander 1/4" Insert: P
452-00417	BI-CC-1/4BR-Q	Tire Brander 1/4" Insert: Q
452-00418	BI-CC-1/4BR-R	Tire Brander 1/4" Insert: R
452-00419	BI-CC-1/4BR-S	Tire Brander 1/4" Insert: S
452-00420	BI-CC-1/4BR-T	Tire Brander 1/4" Insert: T
452-00421	BI-CC-1/4BR-U	Tire Brander 1/4" Insert: U
452-00422	BI-CC-1/4BR-V	Tire Brander 1/4" Insert: V
452-00423	BI-CC-1/4BR-W	Tire Brander 1/4" Insert: W
452-00424	BI-CC-1/4BR-X	Tire Brander 1/4" Insert: X
452-00425	BI-CC-1/4BR-Y	Tire Brander 1/4" Insert: Y
452-00426	BI-CC-1/4BR-Z	Tire Brander 1/4" Insert: Z

CHARACTER SETS

Ascot No.	Mfg. No.	Description	Ascot No.	Mfg. No.	Description
452-00001	TBINOSET	1" Tire Brander Number Set	452-00014	TBI/4NOSET	1/4" Tire Brander Number Set
452-00011	TBILETSET	1" Tire Brander Letter Set	452-00112	TBI/2LETSET	1/2" Tire Brander Letter Set
452-00012	TBI/2NOSET	1/2" Tire Brander Number Set	452-00114	TBI/4LETSET	1/4" Tire Brander Letter Set

BEAD BREAKERS



“COMBI” TIRE BEAD BREAKER

- Works on a single, two and three-piece truck, agricultural and earthmover tire/rim
- Breaks beads in seconds using 10,000 lbs. of force
- No screws, bolts or attachments
- “Combi” bead breaker will not work on five-piece earth mover giant wheel/rim

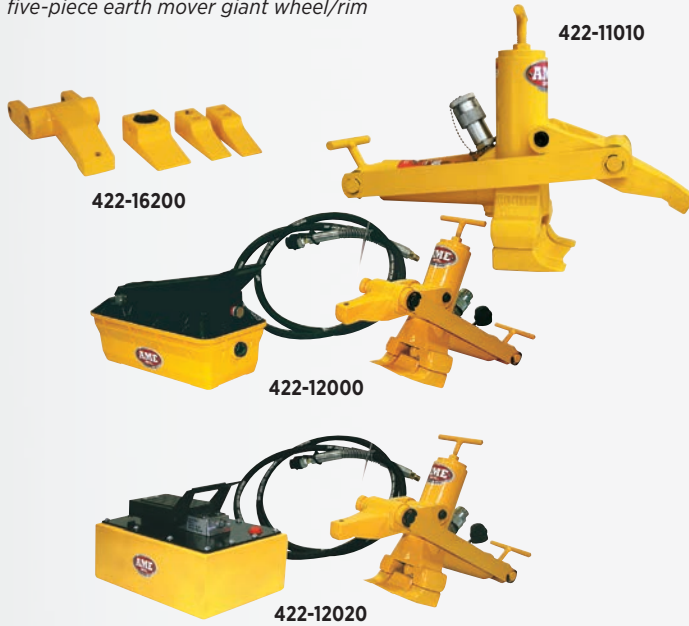

Ascot No.	Mfg. No.	Description
422-11010	11010	Bead Breaker
422-12000	12000	Bead Breaker Kit. INCLUDES: 11010 Bead Breaker, 15000 Pump and 16040 Hose Assembly
422-12020	12020	Bead Breaker Kit. INCLUDES: 11010 Bead Breaker, 15920 Pump and 16040 Hose Assembly
422-16200	16200	Conversion Kit for Combi Bead Breaker

MODIFIED “COMBI” TIRE BEAD BREAKER

- Modified 11010, the most popular tool for breaking beads on all agriculture wheels
- Most affordable bead breaker for new 3 piece wheel assemblies
- Modified jaw and feet allow for larger grab on larger wheel assemblies
- Can be used on the front and back side of the wheel assembly
- All parts (except for modified feet and jaw) can be interchanged with 11010

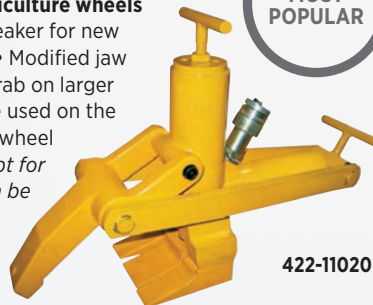

Ascot No.	Mfg. No.	Description
422-11020	11020	Modified “Combi” Tire Bead Breaker

PNEUMATIC BEAD BREAKER



- Recommended for agricultural, small OTR and most truck tires
- **EXTREMELY FAST:** saves time over conventional hydraulic bead breakers
- **LIGHTER WEIGHT THAN CONVENTIONAL BEAD BREAKERS:** only 17 lb.
- Includes storage case
- Requires a minimum of 85 psi



Ascot No.	Mfg. No.	Description
423-00101	GTABB-01	Pneumatic Bead Breaker

“COMBI” HYDRAULIC TIRE BEAD BREAKER



- The ESCO Professional Bead Breaker Series have become a staple in the tire service industry for well over 30 years
- Works on single, two and three-piece truck tires/rims
- Breaks beads in seconds using 13.8 tons of force
- Weighs 36 lbs. (16 kg)
- Also available in kits



Ascot No.	Mfg. No.	Description
422-10101	10101	Bead Breaker Tool
422-10200	10200	Bead Breaker Kit. INCLUDES: Bead Breaker, 3 1/2 qt. Turbo II Hydraulic Air Pump, Hose Assembly and Whip-Hose, Air Reducer
422-10201	10201	Bead Breaker Kit. INCLUDES: Bead Breaker, 2 1/2 qt. Turbo II Hydraulic Air Pump, Hose Assembly and Whip-Hose, Air Reducer
422-10202	10202	Bead Breaker Kit. INCLUDES: Bead Breaker, 5 qt. Turbo II Hydraulic Air Pump, Hose Assembly and Whip-Hose, Air Reducer
422-10825	10825	Bead Breaker Kit. INCLUDES: Bead Breaker, Yellow Jackit 5 qt. Plastic Air Pump, Hose Assembly and Whip-Hose, Air Reducer
422-10839	10839	Bead Breaker Kit. INCLUDES: Bead Breaker, Yellow Jackit 5 qt. Metal Air Pump, Hose Assembly and Whip-Hose, Air Reducer



BEAD BREAKERS



GIANT TIRE/EARTHMOVER TIRE BEAD BREAKER

- Use on 5-piece rims 15" to 51" without pry bar/bead loosening pockets
- Model 15000, 15920 or 15040 air/hydraulic pump recommended for operation
- Replaces Goodyear TO-100-HA

Ascot No.	Mfg. No.	Description
422-11040	11040	Giant Tire/Earthmover Tire Bead Breaker



422-11040

GIANT TIRE/EARTHMOVER TIRE BEAD BREAKER

- 4-1/4" stroke, 14-ton ram will break the toughest beads
- Use on 5-piece rim 25" to 51" with pry bar/bead loosening pocket
- Replaces Goodyear TO-1600-HA
- Same as IMT-1800
- Model 15000, 15020 or 15040 air/hydraulic pump recommended

Ascot No.	Mfg. No.	Description
422-11000	11000	Bead Breaker
422-12070	12070	Bead Breaker Kit. INCLUDES: 11000 Bead Breaker, 15000 Pump, 16040 Hose Assembly
422-12090	12090	Bead Breaker Kit. INCLUDES: 11000 Bead Breaker, 15920 Pump, 16040 Hose Assembly



422-11000



The Giant Tire/Earthmover Tire Bead Breaker in use.

TITAN EARTHMOVER BEAD BREAKER

- Ideal for tire dealer who requires occasional use of bead breaker
- 10-ton cylinder has enough force to break most beads
- 4" (10 cm) stroke length
- Unit will work on 5 piece wheels with bead loosening pockets
- WEIGHT: 34 lbs. (15.5 kg)

Ascot No.	Mfg. No.	Description
422-11005	11005	Titan Earthmover Bead Breaker

422-11005



OTR GIANT TIRE BEAD BREAKER

- Compact, lightweight tool used primarily on 25" and 29" earthmover wheels
- Originally marketed as Goodyear TO-1600-HA
- Works only on 5 piece wheels with bead loosening pockets
- 2 1/8" (5.4 cm) stroke
- 10 tons of hydraulic force
- Used with 10,000 PSI (700 bar) air/hydraulic pump
- WEIGHT: 23 lbs. (10 kg)

Ascot No.	Mfg. No.	Description
422-11050	11050	OTR Giant Tire Bead Breaker

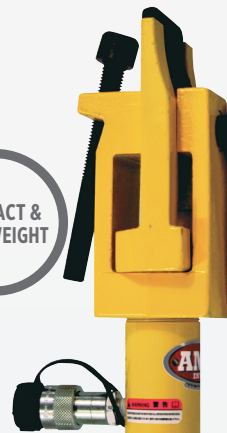

422-11050



OTR 3000 GIANT TIRE BEAD BREAKER

- Designed specifically to work on Topy and Rimex OE wheels found on Terex, Komatsu, Liebherr and Le Tourneau
- Designed to prevent the tool from kicking out while under load • 6' Stroke ram delivers maximum force • New Universal Jaw design works on ALL wheels 51" - 63" • WEIGHT: 54 lbs. (24.5 kg)



422-11044

Ascot No.	Mfg. No.	Description
422-11044	11044	OTR 3000 Giant Tire Bead Breaker

DUAL AGRICULTURAL 300 TIRE BEAD BREAKER

- Designed for all agricultural applications • Lightweight and easy to handle • Requires only 4 1/2" (11.5 cm) operating space • 5 Tons of pushing force • Opens to 12" (30.5 cm) wide • WEIGHT: 20 lbs. (9kg)



422-11065

Ascot No.	Mfg. No.	Description
422-11065	11065	Dual Agricultural 300 Tire Bead Breaker

DUAL AGRICULTURAL TRACTOR TIRE BEAD BREAKER

- HEAVY DUTY: 10-tons of force breaks the toughest beads
- Breaks inside bead on outside dual farm tractor tires
- Requires just 3" of operating space between dual tractor tires • Use with 10,000 PSI air/hydraulic pump • No need to remove outside wheel to change tire on outside dual



422-11060

Ascot No.	Mfg. No.	Description
422-11060	11060	Dual Agricultural Tractor Tire Bead Breaker

TITAN FARM TIRE BEAD BREAKER

- Ideal for tire dealer who requires occasional use of bead breaker • 10-ton cylinder has enough force to break most beads • 4" (10 cm) stroke length
- Unit will break all single and 2-piece and most 3-piece wheels
- WEIGHT: 34 lbs. (15.5 kg)



FOR OCCASIONAL USE

Ascot No.	Mfg. No.	Description
422-11015	11015	Titan Farm Tire Bead Breaker

422-11015

GIANT TIRE/EARTHMOVER TIRE BEAD BREAKER

- Use on all 39", 45", 49", 51", 57" and 63" wheel sizes • In most cases you must first use Model 10105 or 10100 bead breaker to start the movement of the rim flange. Model 11030 can then be used • Model 15020 or 15040 air/hydraulic pump recommended for operation
- Replaces Goodyear TO-2000-HA



422-10103

Ascot No.	Mfg. No.	Description
422-10103	11030	Giant Tire Earthmover Bead Breaker
422-12110	12110	Kit Contains 11030 Bead Breaker, 15040 Pump And 16020 Hose Assembly



GIANT TIRE/ EARTHMOVER BEAD BREAKER

- Use on 5-piece 25" to 51" with pry bar/ bead losing pockets
- Ram will break the toughest of beads
- Use with 10,000 PSI Hydraulic Pump



422-10100

Ascot No.	Mfg. No.	Description
422-10100	10100	Giant Tire/Earthmover Bead Breaker



BEAD BREAKERS



TITAN PRO MODIFIED COMBI BEAD BREAKER

- Compact design allows tool to be used on front or back of wheel
- Ideal to break large OTR 3-piece wheels
- Larger clamp and feet allow tool to easily clamp onto wheels
- Most parts interchange with common bead breakers in the market
- Designed for use on 25" multi-piece wheels
- Tire Sizes: 23.5x25, 26.5x25, 29.5x25 • 11 Ton - 10,000 PSI (700 BAR)



422-11025

Ascot No.	Mfg. No.	Description
422-11025	11025	Titan Pro Modified Combi Bead Breaker



STINGER BEAD BREAKER

- OTR Bead Breaker for heavy duty
- 3-piece rims that replace standard 5-piece rims
- Works on both front and back of wheel without dismounting wheel from vehicle
- Works on all new 3-piece 25" wheels or larger
- Works on all wheels with CAT "Shur-Lok" safety feature



318-11090

"SHUR-LOK" SAFETY FEATURE

Ascot No.	Mfg. No.	Description
318-11090	11090	Stinger Bead Breaker



COMBI STYLE ALUMINUM BEAD BREAKER

- Lightweight aluminum construction
- 10 tons of bead breaking force
- Comparable to the Model #10101 Combi bead breaker
- To be used on 3-piece wheel assemblies
- Extended jaw for deep dish style wheels (extended flange)



422-40801

Ascot No.	Mfg. No.	Description
422-40801	40801	COMBI Style Aluminum Bead Breaker



DIAMONDBACK ALUMINUM BEAD BREAKER KIT

- Lightweight Aluminum reduces weight by 40%
- Longer feet allow better fit onto wheel/rim
- Feet fully engage rim flange and push against the bead of the tire
- WEIGHT: 31 lb. (14kg)



422-11076

LIGHTWEIGHT ALUMINUM

Ascot No.	Mfg. No.	Description
422-11076	11076	Diamondback Aluminum Bead Breaker Kit

FLOOR TYPE BEAD BREAKER

- Use on custom wheels, without center holes, wide based motorcycle tires, ATV tires
- Used to prevent bending of wheels



PREVENTS BENDING OF WHEELS

421-00098

Ascot No.	Mfg. No.	Description	Tread Width	Weight
421-00098	T98	Deluxe	Up to 11"	28.5 lb.

PORTABLE BEAD BREAKER

- Breaks beads on most sizes of passenger tires & light trucks



421-00100

Ascot No.	Mfg. No.	Description	Handle Length	Weight
421-00100	T100	Portable Bead Breaker	36"	5.2 lb.

WINNTEC WHEEL BREAKER SET

- Provides a safe and easy way to loosen oxidized (stuck) wheels
- Simply place the ram between the duals or between the inside wheel & frame
- The manual pump allows the technician to feel how much pressure is being applied
- Adaptors included for wider work spaces



422-47180

Ascot No.	Mfg. No.	Description
422-47180	G471180	Winntec Wheel Breaker Set

10-TON CHASSIS BEAD BREAKING KIT

- Great for use in multiple applications in the tire/wheel service market and many more
- Ideal for low clearance applications
- Easy snap in extensions
- Made of high quality steel
- **Most versatile 10 Ton Ram on the market** - Easy to switch out extensions for optimal extension length
- Includes Carrying Case

422-10316



Ascot No.	Mfg. No.	Description
422-10316	10316	ESCO Stak-Able Hydraulic Ram Kit

PRO SERIES 3 QUART AIR/HYDRAULIC PUMP

- Equipped with an air exhaust muffler for quiet pumping of air motor
- Air and oil inlet filters for reducing risk of damage from contamination
- Internal pressure relief valve system (load limit device) for overload protection
- Engineered with durable lightweight and corrosive resistant plastic components - increasing the life of the air motor and hydraulic pump
- Includes installable fluid level dip stick to check that the appropriate amount of hydraulic fluid is installed
- Hydraulic hose sold separately

318-10518



Ascot No.	Mfg. No.	Description
318-10518	10518	ESCO Pro Series 3-Qt. Air/Hydraulic Pump

SLIDE HAMMER BEAD BREAKER

- Protect your expensive wheels from swinging hammers by breaking the bead loose with this slide hammer
- Use only on wheels without a hump

427-12026



Ascot No.	Mfg. No.	Description
427-12026	12026B	Slide Hammer Bead Breaker

IMPACT BEAD BREAKER

- Loosens the most stubborn beads with floating bead breaking foot and ram bar
- Forces wedge foot between head and rim flange
- Delivers blow directly to the tip
- Designed for shop or road use



427-35926



427-45926

Ascot No.	Mfg. No.	Description	Length	Length Ext.	Weight
427-35924	T24B	Economy	46"	72"	13.5 lb.
427-35926	T26B	Heavy Duty	50"	80"	23 lb.
427-45926	35926-11	Impact Bead Breaker Replacement Grips			



SPECIALTY IMPACT DRIVEN OFF-ROAD DEMOUNTER

- Safe, Easy and Fast way to demount the second bead on a wide range of tires with difficult stiff sides
- Works Great for Sprinkler and Off-Road Super Single Float Tires
- Pulls Wheel Off of the Tire
- Built to be used on tough Superwides
- 100% Pneumatic Tool - Can be used with Impact Gun
- Lightweight and build strong to withstand contact use

402-20418



Ascot No.	Mfg. No.	Description
402-20418	20418	Impact Driven Off-Road Demounter



BEAD SEATING DEVICES



RPG 5-GALLON BEAD SEATERS

- 5-gallon capacity
- Equipped with a butterfly valve for maximum air discharge
- Designed for commercial use on large truck tires, passenger and ATV tires to 24.5"
- Rubber foot pads to lessen vibration
- Made in Taiwan

Ascot No.	Mfg. No.	Description
473-01500	RPG-05GAL	5-Gallon Bead Seater with Butterfly Valve
473-02505	RPG-05GALED	5-Gallon Bead Seater with Butterfly Valve - End Discharge
473-02501	RPG-05GALAL	5-Gallon Bead Seater with Butterfly Valve - ALUMINUM



473-01500

473-02505



RPG 10-GALLON BEAD SEATERS

- 10-gallon capacity
- Equipped with a butterfly valve for maximum air discharge
- Designed for commercial use on large truck tires, passenger and ATV tires to 24.5"
- Made in Taiwan

Ascot No.	Mfg. No.	Description
473-02510	RPG-10GAL	10-Gallon Bead Seater with Butterfly Valve
473-02511	RPG-10GALAL	10-Gallon Bead Seater with Butterfly Valve - ALUMINUM

473-02510



RPG 13-GALLON BEAD SEATER

- Aluminum tank
- 10-gallon capacity
- Equipped with a butterfly valve for maximum air discharge
- Designed for commercial large truck tires 24" to 54"
- Made in Taiwan

Ascot No.	Mfg. No.	Description
473-02513	RPG-13GALAL	13-Gallon Bead Seater with Butterfly Valve - ALUMINUM



473-02513

RPG BEAD SEATERS PARTS & ACCESSORIES

Ascot No.	Mfg. No.	Description
473-01502	RPG-05GAL-02	Safety Valve for RPG Bead Seater
473-01504	RPG-05GAL-04	Butterfly Valve for RPG Bead Seater
473-01505	RPG-05GAL-05	Threaded Barrel for RPG Bead Seater
473-01506	RPG-05GAL-06	Air Pressure Gauge for RPG Bead Seater
473-01507	RPG-05GAL-07	1-1/2" Pipe Nipple for RPG Bead Seater
473-01508	RPG-05GAL-08	1-1/2" Lock Nut for RPG Bead Seater
473-01509	RPG-05GAL-09	90° NPT Elbow for RPG Bead Seater
473-01510	RPG-05GAL-10	Ball Valve for RPG Bead Seater
473-01511	RPG-05GAL-11	Rubber Pad for RPG Bead Seater

Ascot No.	Mfg. No.	Description
473-01512	RPG-05GAL-12	Rounded Head Bolt for RPG Bead Seater
473-01513	RPG-05GAL-13	Handle for RPG Bead Seater
473-01514	RPG-05GAL-14	Handle Nut for RPG Bead Seater
473-01515	RPG-05GAL-15	Valve Body for RPG Bead Seater



38-LITER BEAD BOOSTER

- Newly-patented Turbo Barrel option delivers even greater volume of air by drawing surrounding air into the tire chamber upon firing
- 38L (10-gallon) Bead Booster™ for larger tires
- 2" RAR Valve release for added release velocity
- Aluminum tank weighs only 28 lbs.
- Includes new trigger safety



Ascot No.	Mfg. No.	Description
473-00038	GB38L	38-Liter Bead Booster w/ Jet Assisted Barrel

VIPER™ BEAD SEATERS

- Push button discharge
- Unique handle design for stability and control
- ASME Certified
- Rapid release of air
- Newly designed jet barrel for greatly increased air volume delivery
- More power less air pressure
- Reduces air noise
- Greater air distribution
- No wheel damage
- Works on large range of tires



Ascot No.	Mfg. No.	Description
473-01110	VP 10S	Viper™ 11.5 Liter Bead Seater, Steel Tank
473-01113	VP 13AL	Viper™ 13 Liter Bead Seater, Aluminum Tank
473-01118	VP 18AL	Viper™ 18 Liter Bead Seater, Aluminum Tank



473-01110



473-01113



473-01118

*Please note we recommend the use of a good quality inline filter to remove contaminants and moisture.
 *Please note we recommend the use of silicone spray or air tool oil occasionally to properly maintain the valve.

BEAD SEATING DEVICES



5-GALLON CHEETAH BEAD SEATER

- Makes seating the most difficult bead safe and simple
- 5-gallon capacity • **APPLICATIONS:** Designed for commercial use on large truck tires, passenger and ATV tires to 24.5" • Fill tank from any service station chuck or service truck air compressor



473-00500

- Includes easy carry handle for portability
- Features a 5-gallon ASME-certified steel tank w/powder coat finish for durability
- Quick-release 1-1/2" butterfly valve allows for full impact of air discharge into tire
- Lip on threaded barrel allows for proper angle for air insertion for correct bead seating
- 1/4" air inlet shutoff valve allows for filling the correct amount of air for the size of tire being seated
- Pneumatic gauge makes it easy to fill the correct amount of air for the size of tire being seated

Included mounting feet makes storing the unity easy and helps protect the barrel assembly from damage (not shown)

Ascot No.	Mfg. No.	Description
473-00500	CH-5	Cheetah Bead Seater, 5-Gallon
473-00501	CH-5AL	Same As Above With Aluminum Tank

10-GALLON CHEETAH BEAD SEATER

- 10-gallon capacity with ASME certified tank • **APPLICATIONS:** Designed for small rear agri/grader or smaller tires; Standard for fleet work, farm and service trucks



473-00010

Ascot No.	Mfg. No.	Description
473-00010	CH-10	10-Gallon
473-00011	CH-10AL	10-Gallon With Aluminum Tank

13-GALLON CHEETAH BEAD SEATER

- 13-gallon capacity with ASME certified tank
- **APPLICATIONS:** Seats bead on tractor & heavy equipment tires from 24.5" to 54" • Includes a straight barrel, new Magnum barrel (for larger tires) and safety goggles as standard equipment
- Extends tire service capability not possible with smaller units



473-00013

Ascot No.	Mfg. No.	Description
473-00013	CH-13AL	13-Gallon With Aluminum Tank

BS-07 CHEETAH BEAD SEATER

- "End of Tank" discharge design, flared discharge barrel and a 2" discharge valve for maximum bead seating power
- Makes seating the most difficult bead not only safe but simple, fast and economical • 5-gallon capacity, ASME certified tank
- **SIZE:** 34"(L) x 12"(W) x 15"(H)



473-00207



Ascot No.	Mfg. No.	Description
473-00207	BS-07	BS-07 Cheetah Bead Seater

CHEETAH BEAD SEATER REPLACEMENT PARTS



Ascot No.	Mfg. No.	Description
473-01104	'01.104	1-1/2" Pipe Nipple for Cheetah Bead Seaters
473-01106	'01.106	Pressure Gauge for Cheetah Bead Seaters
473-01107	'01.107	3/4" - 1/4" Bushing for Cheetah Bead Seaters
473-01109	'01.109	Cheetah Air Hose Assembly
473-01230	'01.230BT	Handle & Nut for Butterfly Valve for Cheetah Bead Seaters
473-02102	'02.102	1-1/2" Discharge Valve for Cheetah Bead Seaters

Ascot No.	Mfg. No.	Description
473-02103	'02.103	1-1/2" Threaded Barrel for Cheetah Bead Seaters
473-02106	'02.106	Magnum I Barrel for Cheetah Bead Seaters
473-02107	'02.107	1-1/2" Lock Nut for Cheetah Bead Seaters
473-03102	'03.102	2" Discharge Valve for Cheetah Bead Seaters
473-03103	'03.103	2" Barrel for Cheetah Bead Seaters

Ascot No.	Mfg. No.	Description
473-03104	'03.104	90° NPT for Cheetah Bead Seaters
473-03106	'03.106	Magnum II Barrel for Cheetah Bead Seaters
473-04103	'04.103	Ball Valve for Cheetah Bead Seaters
473-05102	'05.102	Safety Release Valve for Cheetah Bead Seaters
473-06813	'6813	Flared Barrel for BS-07 for Cheetah Bead Seaters



HURRICANE HIGH-FORCE BEAD SEATERS

- All models equipped with robust air tanks, cast out of aluminum and ASME certified
- Lightweight hassle-free, simple solution to seat the beads on small ATV up to OTR-sized tires
- Fast, easy and powerful push button style discharge system
- Designed to support full control of tank while seating tire/wheel
- "High-Force" Discharge Barrel for precise, maximum air release for best seating of the bead the first time
- Safety glasses and ear protection included
- Maximum PSI: 165 PSI
- Recommended Operating Pressure: 40-155 PSI



Ascot No.	Mfg. No.	Description	Weight	Dimensions	Applications
473-20387	20387	Hurricane Cat-5 Push Button Alum Bead Seater, 5-Gallon	19 lbs.	30" x 11" x 12.5"	Small and passenger tires
473-20388	20388	Hurricane Cat-9 Push Button Alum Bead Seater, 9-Gallon	23 lbs.	28" x 14" x 14.5"	Most commercial tire sizes, skid steers & some tractor tires
473-20389	20389	Hurricane Cat-13 Push Button Alum Bead Seater, 13-Gallon	24 lbs.	31" x 14" x 15"	Heavy-duty truck applications, most construction & agricultural tires





BEAD BAZOOKA®

- Smaller and more powerful than previous designs
- Serviceable/Replaceable 2" RAR valve
- Utilizes ultra-compact design
- Anti-corrosion interior tank coating
- Perfect for motorcycle, cars, or light commercial vehicle tire service (3L2)
- Perfect for cars and commercial vehicle tire service (6L2)
- Perfect for commercial and light agricultural vehicle tire service (10L2)

BEAD SEATING DEVICES

SMALLER & MORE POWERFUL

UPGRADED RELEASE VALVE

BEAD BAZOOKA®

Ascot No.	Mfg. No.	Description	Weight	Dimensions	Inner Diameter
473-00103	GBB3L2	Bead Bazooka 3L2	14 lbs.	23" x 6" x 12"	4 in.
473-00106	GBB6L2	Bead Bazooka 6L2	15 lbs.	23" x 7" x 12"	4.75 in.
473-00110	GBB10L2	Bead Bazooka 10L2	18 lbs.	30" x 7" x 12"	5.5 in.
473-00100	BBVRK	Bead Bazooka Valve Repair Kit	N/A	N/A	N/A



473-00103



473-00106



473-00110



The Bead Bazooka® 3L2 in use.

BEAD BAZOOKA® SPARE PARTS:

Ascot No.	Mfg. No.	Description
473-12913	12913B	Slotted Double Barrel
473-12914	12914B	Pressure Gauge
473-12915	12915B	Y-Connect
473-12916	12916B	Intake Valve
473-12917	12917B	Safety Valve
473-12919	12919B	Switch Valve
473-12920	12920B	Grip with Trigger Guard
473-12921	12921B	Plastic Plug
473-12923	12913BC	Slotted Double Barrel without Clip
473-12930	12930M	F3 Connector



473-00100



473-12914



473-12930



473-12916



473-12917



473-12920



473-12923



JET PAK BEAD SEATER UPGRADE DEVICE

- **Faster and easier than standard ball or butterfly discharge valve operation** • Discharges tank with the press of a button • Safety cover prevents accidental trigger release
- **TWO PORT SIZES AVAILABLE:** CH1.5JP (1.5") and CH2.0JP (2") to fit any standard bead seater in a variety of tank sizes • Attaches easily to existing pipe nipple, replacing manual discharge valve • *Includes our new improved Jet Barrel (VP 3.103 or VP 2.103) for greater air volume delivery* • Comfortable handle assures firm grip and ease of use
- All internal components can be removed and serviced if required



GREATER AIR VOLUME

473-00020



GAITHER RAR VALVE UPGRADE KITS

- **The Gaither RAR Valves are the most powerful inflation valves available - same as used on the popular Bead Bazookas** • 1.5" and 2" available to upgrade your current inflation tank • Completely serviceable!! This means that if something should become defective down the road, the seal, valve, spring or all three can be replaced!
- Push-button release trigger allows technician to keep both hands on the tank for optimum control during use
- Reversible handle allows for both right hand and left hand users based on preference
- *Each valve includes a barrel for immediate use after installation*



473-12941

473-12942



EASY-LIFT™ BEAD SEATING STAND

- **Portable for field service, or can be bolted to the floor** • With hub facing out, simply roll mounted tire and wheel assembly to front of stand • Push assembly onto crown - tire and wheel will automatically fall onto center of stand and rest with bead centered on bottom wheel flange • Seat beads by inflating tire to 4 PSI (max.) • Step around stand and easily lift assembly into vertical position • Roll assembly into tire inflation safety cage for final inflation
- **SIZE:** 4"H x 26"W x 27"L
- Made of high grade steel

HIGH GRADE STEEL

PORTABLE IF NEEDED



473-36016



Ascot No.	Mfg. No.	Description
473-00020	CH-2.0JP	Jet Pak Bead Seater Upgrade Device - 2" Port Size
473-00015	CH-1.5JP	Jet Pak Bead Seater Upgrade Device - 1.5" Port Size

Ascot No.	Mfg. No.	Description
473-12941	12941R	1.5" RAR Valve Upgrade Kit
473-12942	12942R	2" RAR Valve Upgrade Kit

Ascot No.	Mfg. No.	Description	Weight
473-36016	36016	Std. Crown for 8-3/4" Dia. Hubs	16,000 lb.
473-36017	36017	Large Crown for 11" Euro Hubs	12,000 lb.

BEAD SEATING DEVICES



GAITHER'S BEAD SAVER SYSTEM

• By using simple principles of leverage, the Bead Saver System actually works with tire and rim to do the work for you • Patented design • Safest, fastest, easiest way ever invented to change tubeless truck tires • Guaranteed not to damage tire beads



Ascot No.	Mfg. No.	Description
448-12880	12880	Bead Saver System



448-12880

PNEUMATIC BEAD EXPANDERS

• Fits most bias ply passenger tires • Pliable neoprene rubber tube encased in tough nylon cover • Withstands contact with oil, grease, solvents and acid

Ascot No.	Mfg. No.	Min./Max. Diam.	Tube Diam.	Weight
471-31432	31432	24"-34"	2-1/4"	2.8 lb.
471-31433	31433	22"-32"	3/4"	.75 lb.



471-31432

GAITHER J1 MOUNT/DEMOUNT TOOL

• Slightly altered and condensed version of the original Bead Saver System • 2-piece system that mounts and dismounts all standard 19.5", 22.5" and 24.5" tubeless tires up to a 315/80R22.5, including those mounted on aluminum wheels • Differs from the original system in that each process is done completely while the tire is flat on the ground • The first Bead is dismounted with the clevis & crook/spoon end • The second Bead is dismounted with the J-1 end without picking the tire up • The first bead can be mounted with the J-1 end • The second Bead is mounted with the spoon end • Two Beadkeepers can be used to assist with mounting

Ascot No.	Mfg. No.	Description
448-00001	J1	Mount/Demount Tool



448-00001

GAITHER SUPER SLICK'EM™

• Gaither's Super Slick'em™ should be applied to all tires before being mounted or before deflation if being dismounted • Super Slick'em™ is a special non-water based lubricant that penetrates and aids in breaking the tire bead from the wheel by eating away rust and grease. Because it does not contain water, Super Slick'em™ will not freeze or cause rust to form • SUPER SLICK'EM™ 12904 INCLUDES: 4-1 gallon (3.8 liter) containers and 1 applicator bottle

Ascot No.	Mfg. No.	Description
421-12904	G12904	Gaither Super Slick'em™



421-12904



5-GALLON BEAD BOOSTER

- Creates a blast of air used for seating tubeless tire beads
- Release valve safety lock prevents inadvertent discharge
- Powder-coated inside and out to protect from rust and deterioration caused by moisture
- Double Barrel directs the air around the tire for a better "lift"
- Safety pop-off valve prevents overloading with too much air pressure

473-00005



DOUBLE BARREL

Ascot No.	Mfg. No.	Description
473-00005	GB-5Z	5-Gallon Bead Booster

5-GALLON BEAD BOOSTER WITH MIS VALVE

- The BEAD BOOSTER® GB-5M comes equipped with the same MIS valve as the famous BEAD BAZOOKA® Tommy Gun giving it the ability to seat almost any tire
- CE/ASME certified tank
- New MIS valve with a 2" opening
- Internal proprietary coating protects against rust
- Includes Gaither's trusted 3 year warranty

473-42561



EQUIPPED WITH MIS VALVE

Ascot No.	Mfg. No.	Description
473-42561	GB-5M	5-Gallon Bead Booster with MIS Valve

YELLOW RUBBER COATED BEADKEEPER

- Keeps truck tire bead from slipping during mounting of top bead
- Rubber coated steel construction
- Will not scratch aluminum wheels
- Great for hard to mount tires, a must for all super singles
- Equivalent to Gaither 12894C & ESCO 70140

448-12894



Ascot No.	Mfg. No.	Description
448-12894	12894C	Yellow Rubber Coated Beadkeeper

BLUE WIDE MOUTH RUBBER COATED BEADKEEPER

- Wider mouth works on newer, wider Alcoa wheels
- Keeps truck tire bead from slipping during mounting of top bead
- Rubber coated steel construction
- Will not scratch aluminum wheels
- Great for hard to mount tires, a must for all super singles
- Equivalent to Gaither 12894-CW

448-32894



Ascot No.	Mfg. No.	Description
448-32894	12894-CW	Wide Mouth Blue Rubber Coated Beadkeeper

STEEL BEADKEEPER

- THE ORIGINAL BEADKEEPER®
- Used to hold a tire bead in place during the mounting process
- Eliminates the need to stand on the tire and/or use a second mounting bar

448-22894

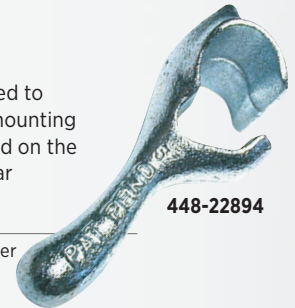

Ascot No.	Mfg. No.	Description
448-22894	12894	Steel Beadkeeper

BEADKEEPERS-ON-A-ROPE

- Used to hold the tire in place while mounting the second bead
- These tools eliminate the dangerous job of standing on the tire in order to mount it
- After the first bead is mounted, simply place two Beadkeepers on the flange of the wheel and spread them apart as far as possible; Use the Spoon End of the bar to mount a small part of the bead and slide the closest Beadkeeper to the bar; Repeat this step until the entire second bead is mounted

448-42894

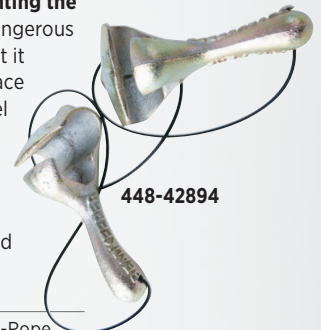

Ascot No.	Mfg. No.	Description
448-42894	12894-P	Beadkeepers-On-A-Rope

CHLORIDE PUMPS



VALVE ADAPTER GUN

- Will attach to any calcium tire filling pump • 1/2" female pipe thread • Will extract valve core from a standard bore valve or core housing from tractor valve • Securely holds valve core or core housing up in the gun body during the filling or evacuation of liquid from tire

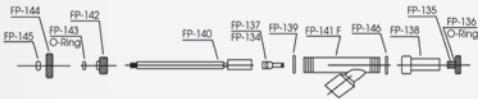

464-00310



Ascot No.	Mfg. No.	Description
VALVE ADAPTER GUN PARTS		
464-00134	FP-134	Large Bore Core Remover
464-00135	FP-135	Adapter For Standard Valve
464-00136	FP-136	O-Ring For FP-135
464-00137	FP-137	Standard Valve Core Remover
464-00138	FP-138	Ejector Union With FP-136 O-Ring
464-00139	FP-139	Gasket
464-00140	FP-140	Stem
464-00141	FP-141F	Adapter Body
464-00142	FP-142	Stem Sealing Nut
464-00143	FP-143	O-Ring For FP-142
464-00144	FP-144	Hand Wheel
464-00145	FP-145	Lock Nut
464-00146	FP-146	Teflon Gasket

Ascot No.	Mfg. No.	Description
464-00310	310	Valve Adapter Gun

MTP, Inc. CALCIUM CHLORIDE PUMP

- Now available with polyvinyl valve (Model #10509) or anodized aircraft aluminum valve (Model #10509M) • Pumps 34 gallons of calcium chloride per minute • Newly designed valve will not leak • Spring reinforced hoses for fill and evacuate • Comes complete with valve adapters for all valves (large bore and standard) • Gauges are protected • Unit is portable or can be mounted in tire service trucks • Double diaphragm pump, 1 to 1 ratio • 10' hoses gives plenty of room to operate • Includes hoses & calcium tire filled gun • USA MADE PUMP

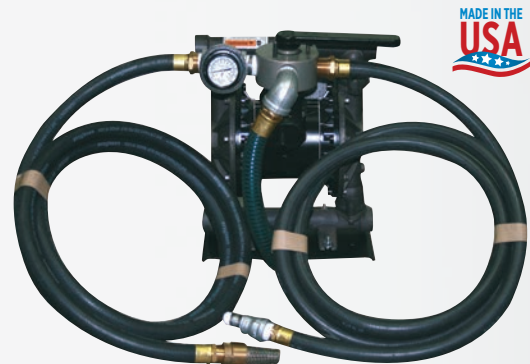

475-11590

Ascot No.	Mfg. No.	Description
475-10509	10509	Calcium Chloride Pump with Polyvinyl Valve
475-11590	10509M	Calcium Chloride Pump with Aircraft Aluminum Valve

GRACO CALCIUM CHLORIDE PUMP

- 50-gallon (189 liter) per minute capacity; 1 to 1 ratio double diaphragm pump • WEIGHT: 38 lb. (17.2 kg) • Pump only P/N 15091, pump with quick connectors 15090-Q



475-15090

Ascot No.	Mfg. No.	Description
475-15090	15090	GRACO Calcium Chloride Pump



DOUBLE DIAPHRAGM CALCIUM CHLORIDE PUMP

- No lubrication required
- Self-priming, non-stalling, low noise level
- Diaphragms have no stress points and less flex for longer life
- No gradual loss of pump performance due to wear
- Can run dry indefinitely
- Protected by an air filter/regulator
- 35 gallon per minute free flow



Ascot No.	Mfg. No.	Description
475-15103	15103	Double Diaphragm Calcium Chloride Pump
475-30280	A3028	Replacement 4-Way Valve for Calcium Chloride Pump
475-30281	HL-B	Replacement Handle for Calcium Chloride Pump 4-Way Valve

“WONDER PUMP” PNEUMATIC DOUBLE DIAPHRAGM CALCIUM CHLORIDE PUMP



- No lubrication required • Self-priming; non-stalling; low noise level • Diaphragms have no stress points and “less flex” for longer life • No gradual loss of pump performance due to wear • Can run dry indefinitely
- Protected by an air filter/regulator • 4-WAY VALVE: 1/4 turn reverses the flow
- no need to change hoses
- 35 gallon per minute free flow

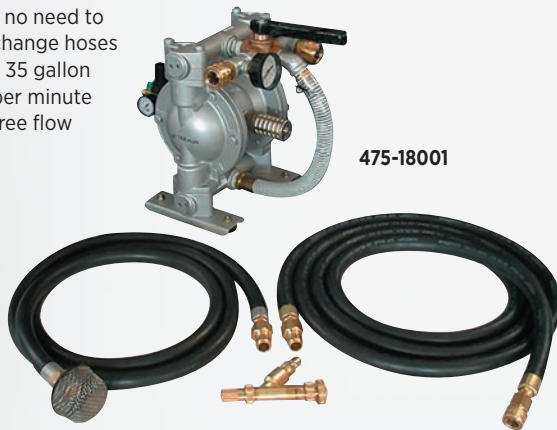

Ascot No.	Mfg. No.	Description
“WONDER PUMP” PARTS & ACCESSORIES		
475-13011	30A-11	310 Calcium Gun
475-13018	30A-18	3/4" Brass Quick Coupler-Hose Saver
475-13019	30A-19	3/4" Brass Plug - Hose Saver (Needed for 30A-18)
475-13021	30A-21	1/2" Brass Quick Coupler - Calcium Gun
475-13022	30A-22	1/2" Brass Plug - Calcium Gun (Needed for 30A-21)
475-13026	30A-26	1/8" Back Mount Air Gauge - 0-100 PSI
475-13027	30A-27	2-1/2" Dia. S.S. 1/4" Back Mount Press/Vac Gauge - 30/0/150 Glycerin Filled
475-82515	682515	Extra Large Exhaust Muffler
475-13028	30A-28	3/4" Brass 4-Way Directional Valve w/ O-Ring Seals w/ Handle
475-13029	30A-29	Handle for 30A-28
475-13030	30A-30	10' Supply Hose (3/4" x 1" MPT Ends) 300 PSI - Wingfoot
475-13031	30A-31	15' Fill/Evac Hose (3/4" x 1/2" MPT Ends) 300 PSI - Wingfoot
475-13032	30A-32	PVC Suction Bypass Hose for Silver Pump
475-13033	30A-33	1" FPT Stainless Steel Strainer for 30A-30 Prior to 2002
475-13034	30A-34	3/4" FPT Stainless Steel Strainer for Current 30A-Plus
475-12532	25A-32	PVC Bypass Hose for Black Pump

Ascot No.	Mfg. No.	Description
475-18001	30A Plus	1" Capacity Standard Package

MOUNT/DEMOUNT TOOLS



GOLDEN TOOL TUBELESS TRUCK TIRE MOUNT DEMOUNT TOOL

• Demounts most tubeless tires in 8 seconds with ease - remount them in 20 seconds with equal ease - all without the need to lift tire and rim to remove rear bead

• Demounts/mounts 17.5" to 24.5" tires
 • **APPLICATIONS:** Use on all tubeless truck tires including super single/duplex tires, radial and bias
 • For Dayton-type wheels (centerless) and Budd type disc wheels • Eliminates the need to lift tire and rim to remove the bottom bead, preventing possible strain or even serious injury

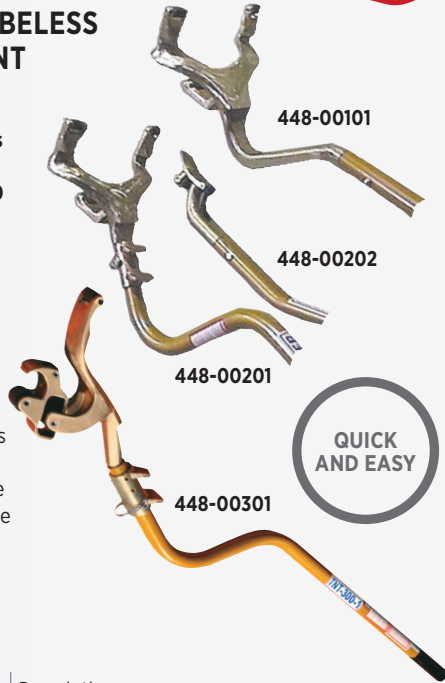

448-00101

448-00202

448-00201

448-00301



Ascot No.	Mfg. No.	Description
448-00100	TNT-100	Tire Mount/DEMOUNT Tool Complete
448-00101	TNT-100-1	Demount Tool Only
448-00200	TNT-200	Super Single Tire Mount/DEMOUNT Tool
448-00201	TNT-200D	Super Demount Tool
448-00202	TNT200M	Single Mount Tool
448-00301	TNT-300-1	New 445 Super Single Demount Tool



GOLDEN BUDDY TIRE CHANGING SYSTEM

• Mount and demount tool assemblies for 22.5 & 24.5 tires/wheels • Heavy duty steel construction ensures long life • Nylon rollers protect the bead • Bead holder • **WEIGHT:** 32 lb. (14.5 kg) • Sold as a complete set



448-12320

Ascot No.	Mfg. No.	Description
448-12320	71050	Golden Buddy Tire Mount/DEMOUNT Tool Set
448-22320	71051	Golden Buddy Demount Assembly
448-32320	71052	Golden Buddy Mount Tool Assembly

EASY BUDDY TIRE DEMOUNT TOOL

• Mount and dismount tire assemblies for 22.5 and 24.5 tires/wheels • Easy-to-follow instructions • **WEIGHT:** 35 lb. (16 kg) • Includes top bead removal tool and bottom bead removal tool • Includes Rim Protector to prevent rim scarring



448-71000

Ascot No.	Mfg. No.	Description
448-71000	71000	Easy Buddy Tire Demount Tool

STEEL TRUCK BEAD HOLDER

• Clamps securely to the wheel to prevent tire from "walking" • Eliminates the use of vise grips which can damage wheels • For use with automatic tire changers and/or manual tire changing tools • Heavy duty steel construction



448-00010

Ascot No.	Mfg. No.	Description
448-00010	BJ-BP10	Steel Truck Bead Holder

BL-100 BEAD LOCK

• Helps prevent bead damage • Large roller directs bead into drop center, making tire mounting easier • Prevent damage to rims • Tool will not slip or dislodge during the mounting process



448-01100

Ascot No.	Mfg. No.	Description
448-01100	BL-100	Bead Lock

TIRE MOUNT/DEMOUNT IRONS



• Many sizes for use on truck, agricultural and industrial tires • **APPLICATIONS:** Straight and offset tire irons for use on large, wide-base tires; T45 series for use on standard truck tires • New 402-45005 allows the professional to lift the bead over the rim with less effort than conventional methods



402-45005

Ascot No.	Mfg. No.	Length	Stock	Weight
402-45003	T45A	37"	3/4"	4.6 lb.
402-45005	T45A-2000K	38"	3/4"	5 lb.
402-45004	T45HD	41"	7/8"	7 lb.
402-47001	T47A	52"	1"	11 lb.



TIRE DEMOUNTING TOOL & KITS

• Removes both top and bottom bead from short side - no need to flip tire/rim • Demounts 22.5" to 24.5" tubeless truck tires with ease • Including most radial and bias ply tires • Demounts tire in 8 seconds • Also available as a kit to include demounting tool, mounting tool and bead holder



402-00201
ESC200
Demount &
Mounting
Tool Kit



402-00100
ESC100
Demounting
Tool

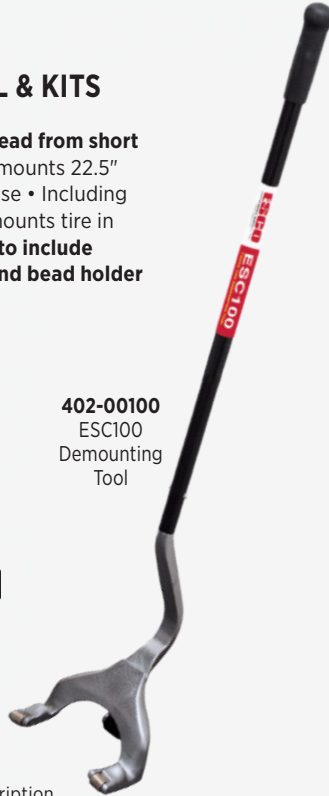

Ascot No.	Mfg. No.	Description
402-00100	90518-100-1	ESC100 Tire Demounting Tool
402-00101	90518-100-KIT	ESC100 Demount & Mounting Tool Kit. Includes: 100 Demounting Tool, 100 Mounting Tool, 70141 Bead Holder
402-00200	90518-200-1	ESC200 Tire Demounting Tool
402-00201	90518-200-KIT	ESC200 Demount & Mounting Tool Kit. Includes: 200 Demounting Tool, 200 Mounting Tool, 70141 Bead Holder



TUBELESS TRUCK TIRE DEMOUNT TOOL

• High Quality, economical price
• Nylon rollers
• 3-Step demount of 22.5 and 24.5 tires
• Parts Available

448-00400



HIGH
QUALITY

Ascot No.	Mfg. No.	Description
448-00400	EZT-100D	Tubeless Truck Tire Demount Tool



TYR-X TRUCK TIRE DEMOUNT SYSTEM

• A safe, quick, and reliable tire demounting tool that makes tire demounting a simple process
• The pivot hooks ensure easy and positive operation and its design eliminates aggressive stretching of the tire bead
• One of the easiest and fastest manual truck tire demounting tool on the market
• Works on standard truck tires (22.5-24.5) and can be used for the first bead of super singles or double wide truck tires • **WEIGHT:** 17 lb. (8 kg)



402-20406



402-20397



402-20430

Ascot No.	Mfg. No.	Description
402-20416	20416-A	Demount Truck Tire Tool Kit. INCLUDES: 20396, 20397, 20430, 20406
402-20396	20396	Demount Tool, Truck Tire, "Tyr-X", All In One Demount System
402-20397	20397	Bead Wedge (Puts Tire In Drop Center)
402-20406	20406	Bead Holder, Commercial Truck Tires (Pair)
402-20430	20430	Mounting Bar, Truck Tires

PLATINUM DEMOUNT TOOL

• Demounts tire sizes 17.5" - 24.5"
• Only a single tool needed to demount tires • Eliminates the need to lift the tire and heel making a hard job easy and protecting against insurance claims • Unique design protects valuable tire casings for retreading • Handle design protects against damage to the tool and other objects that may come in contact



448-12100

Ascot No.	Mfg. No.	Description
448-12100	G12100	Platinum Demount Tool

MOUNT/DEMOUNT TOOLS



IRONMAN™ ERGONOMIC WHEEL LIFTING BAR

- Easily and safely lift heavy, awkward truck tire and wheel assemblies • Extremely useful in outdoor conditions when truck tire and wheel assemblies can become wet & slippery
- Protect your workers and yourself: reduce injuries & claims, keep insurance premiums down
- Specially designed forged ends work from either side of the wheel assembly as it lays flat
- **APPLICATIONS:** Lift all sizes and types of small and large heavy truck wheels: Standard sizes including 22.5" and 24.5" wheels, plus European (which have 1" lug holes), Super Wide and even the Super Single (a 340 lb. assembly) size



402-34950



The Ironman™ Ergonomic Wheel Lifting Bar in use.

Ascot No.	Mfg. No.	Length	Weight
402-34950	34950	58"	10 lb.

NINETEEN-FIVE™ TIRE MOUNTING & DEMOUNTING TOOL SET FOR 19.5" TRUCK TIRES

- New tire bar uniquely designed to work on hub side of wheel, where hub protrudes above rim • Specially designed ends manipulate tire with less effort • Forged from high-grade carbon steel and heat-treated for longlasting strength and durability • **APPLICATIONS:** Specially designed Bead Holder to hold bead on 19.5" aluminum wheels • Solid brass Bead Holder for steel wheels • Aluminum Wheel Protector - thick leather pad helps protect rims from marring and scratching

Ascot No.	Mfg. No.	Description	Length	Weight
NINETEEN-FIVE™ TIRE MOUNTING & DEMOUNTING TOOL SET				
402-33195	33195	Nineteen-Five™ Tire Mounting and Demounting Set. INCLUDES: 31710, 31810, 33196, 33199		
472-31710	31710	Bead Holder for Steel Wheels - Solid Brass	4-1/2"	2.5 lb.
472-31810	31810	Aluminum Wheel Protector - Leather	6"	3.4 lb.
402-33196	33196	Bead Holder for 19.5" Aluminum Wheels	7-1/2"	3 lb.
402-33199	33199	Tire Mounting/ Demounting Tool	38"	2.5 lb.



472-31810



472-31710



402-33196

402-33199

BEAD HOLDER

- Holds the bead in place against the wheel when mounting the tire on the wheel • 31713 Bead Holder works on Super Singles and Super Wides



472-31710



472-31713

Ascot No.	Mfg. No.	Material	Stock	Weight
472-31710	31710	Solid Brass	1.4 lb.	1.8 lb.
472-31713	31713	Aluminum Bead Holder - Works on Super Singles		

ALUMINUM WHEEL PROTECTOR

- Protects wheel rims from damage
- U.S. Patent No. 6,991,018



472-31810

Ascot No.	Mfg. No.	Weight
472-31810	31810	12 lb. (5.4 kg)

BLUE COBRA™ TRUCK TIRE DEMOUNT TOOL

• Ergonomic shaped steel handle with no-slip grip for optimum leverage • **APPLICATIONS:** Change nearly any 20", 22.5" and 24.5" tube-type and tubeless truck tires, up to a 13" wide one-piece wheel

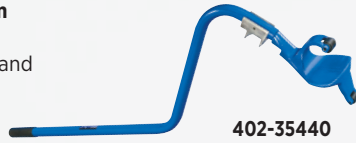

402-35440

Ascot No.	Mfg. No.	Length	Weight
402-35440	35440	54"	22 lb.

SUPER SERPENT DEMOUNT TOOL

• At only 5-1/2 pounds, this unique, lightweight demount tool for super singles can be lugged around on a fingertip • Delivers incredible leverage right where it's needed



402-02006

Ascot No.	Mfg. No.	Length	Stock	Weight
402-02006	T2006	37"	3/4"	5.5 lb.

TIRE SPOONS

• General purpose tire irons for all mounting and demounting needs • **APPLICATIONS:** Use 18" and 24" spoons to mount or demount passenger car, motorcycle, ATV and light truck tires; 30" spoons provide enough strength and leverage to work on large truck, bus, off-road vehicle, tractor and aircraft tires

Ascot No.	Mfg. No.	Length	Stock	Weight
-----------	----------	--------	-------	--------

A. STRAIGHT

402-32101	T1X	18"	11/16"	1.8 lb.
402-32119	T19	24"	11/16"	2.5 lb.
402-33022	33022	30"	3/4"	3.4 lb.
402-33219	T19A	30"	11/16"	3 lb.
402-33238	T38	30"	7/8"	4.8 lb.

B. DROP-CENTER

402-02100	T21R	18"	11/16"	1.8 lb.
402-02101	T21F	24"	11/16"	2.5 lb.
402-02102	T21HD	30"	7/8"	4.5 lb.
402-33020	33020	30"	11/16"	3.1 lb.
402-33024	33024	30"	3/4"	3.4 lb.

C. CURVED

402-31820	31820	18"	11/16"	1.8 lb.
402-32102	T2X	18"	11/16"	1.8 lb.
402-32120	T20	24"	11/16"	2.4 lb.
402-32420	32420	24"	11/16"	2.5 lb.
402-33021	33021	30"	11/16"	3.1 lb.
402-33052	33052	30"	3/4"	3.1 lb.
402-33062	33062	30"	7/8"	3.4 lb.
402-33220	T20A	30"	11/16"	3.1 lb.
402-33239	T39	30"	7/8"	4.5 lb.



A B C



TIRE DEMOUNT TOOL

• Demounts both beads on most truck tires with the need for lifting the tire/wheel assembly off the ground and then dropping it • Heat-treated alloy steel for maximum durability and strength

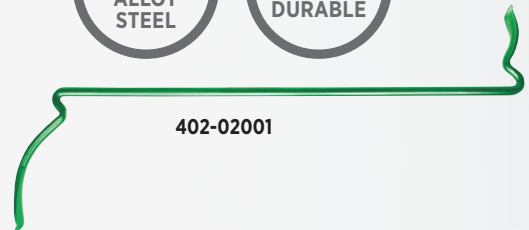

402-02001

Ascot No.	Mfg. No.	Length	Stock	Weight
402-02001	T2001	39"	3/4"	6.5 lb.

TIRE MOUNT TOOL

• Wing shaped designed to stop against rim, remove itself from between rim and bead • Small end gets under stretched bead for last pull



402-02002

Ascot No.	Mfg. No.	Length	Stock	Weight
402-02002	T2002	38"	11/16"	4 lb.

SUPER SERPENT MOUNT TOOL

• It may seem funny looking, but every inch of this innovative design is purely serious • Delivers Twice the leverage of any "Straight-type" tire mounting tool

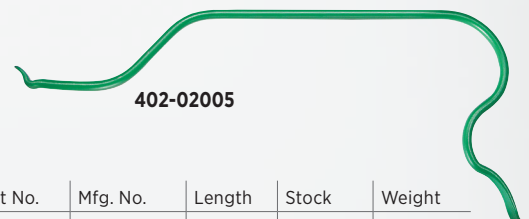

402-02005

Ascot No.	Mfg. No.	Length	Stock	Weight
402-02005	T2005	37"	3/4"	6.6 lb.

PROUD PARTNERS FOR OVER 50 YEARS!

Ken-Tool®

WHEREVER TIRES ARE CHANGED™

ASCOT™
Supply Corporation

TG11E

FIBERGLASS
HANDLED WEDGE



T45A

TIRE IRON



**TIRE MOUNT/
DEMOUNT
SPOONS**

STRAIGHT, DROP-CENTER,
CURVED,
CURVED WITH FLAT



Mega
AIR BLAST™
BEAD SEATING TOOLS



**PREMIUM DIGITAL
TIRE INFLATORS**

24" OR 12" HOSE, CLIP-ON CHUCK AND 8" DUAL
FOOT CHUCK INCLUDED.

LOCKING RING TOOLS



CLASSIC TUBELESS TIRE IRON

- Ken-Tool's patented designs offer one-piece construction and assure long life for many tire changing applications
- Tip ends insert easily and will not cut or rip bead or sidewall
- These designs make it easier to mount and demount tires without changing the way the tool is used
- **MOUNT END:** Precision-forged knob grips rim. Tip designs won't slip during tire mounting. Special curve design always grabs the bead edge
- **DEMOUNT END:** Precision-forged angled tip slides between bead and rim easily. Forged design won't slip when demounting the second bead

402-34645

Ascot No.	Mfg. No.	Length	Stock	Weight
402-34645	T45AC	37"	3/4"	4.6 lb.
402-34649	T45AS	52"	7/8"	8.25 lb.

TUBELESS TIRE IRON SETS

- Sets provide all irons necessary for a variety of tire changing applications
- **APPLICATIONS:** Use C bar with the B extension bar for easier use on large, wide-base truck tires; Use on standard and large truck tires, including industrial, farm, buses and tractors

Ascot No.	Mfg. No.	Description	Length	Stock	Weight
ADAPTER PLUGS					
402-46000	T46	Tire Iron Set. INCLUDES: T46A, T46B, T46C	—	3/4"	12 lb.
402-46001	T46A	Med. Duty Mount/Demount Iron	36"	3/4"	4.5 lb.
402-46002	T46B	Mount/Demount Iron	36"	3/4"	4.5 lb.
402-46003	T46C	Offset Bar For Deep Well Tires	22"	3/4"	3 lb.
HEAVY					
402-47000	T47	Tire Iron Set. INCLUDES: T47A, T47B, T47C	—	1"	29 lb.
402-47001	T47A	Ultra Duty Mount/Demount Iron	52"	1"	11 lb.
402-47002	T47B	Mount/Demount Iron	49-1/2"	1"	11 lb.
402-47003	T47C	Offset Bar For Deep Well Tires	27"	1"	6.66 lb.



TRUCK LOCK RING REMOVER

- **APPLICATIONS:** Designed for small diameter wheels

402-32123

Ascot No.	Mfg. No.	Length	Diameter	Weight
402-32123	T23	24"	11/16"	2.4 lb.
402-33223	T23A	30"	11/16"	3.1 lb.



HEAVY DUTY HAMMERS



FIBERGLASS HANDLE HAMMERS



Ascot No.	Mfg. No.	Handle No.	Length	Head Weight	Weight
425-35421	TG34	TG11CH	18"	5.5 lb.	6 lb.
425-35423	TG35	TG11CH	18"	4.8 lb.	6.6 lb.
425-35425	TG36	TG11CH	18"	5.8 lb.	6 lb.



ALL-WEATHER HEAVY DUTY HAMMERS

• Handles are constructed with a solid core with thousands of fiberglass strands and a unique resin to make them super strong, all-weather, chemical and insect-resistant • Ergonomic non-slip grips for slippery conditions • **MADE IN THE USA**

Ascot No.	Mfg. No.	Description	Details
426-10062	10062	2 lb. Dead Blow Hammer	Engineered to perform better than rubber or plastic face hammers. Shot-loaded composite interior cavities of these Dead Blow hammers are fully encased in a tough polymer outer jacket. Free flowing inner shot concentrates striking power and increases driving force creating a dead blow effect.
426-10064	10064	4 lb. Dead Blow Hammer	
426-10066	10066	2 lb. Dead Blow Hammer w/ Steel face	
426-27804	27804	8 lb. Slugging Hammer	Features drop forged, heat treated and tempered carbon steel sledge heads with dual machined striking faces and chamfers.
426-28045	28045	4 lb. Hand Drilling Hammer	High quality drop forged, heat treated and tempered carbon steel heads with a black crown and polished striking faces.
426-29045	29045	4 lb. Cross-Pein Hammer	High quality forged, heat treated and tempered heads with one radiused pein.
426-30025	30025	2.5 lb. Brass Hammer	High quality cast brass head with polished striking face.



WOODEN HANDLE HAMMERS

• Used for mounting and demounting tires • **APPLICATIONS:** Makes tire changing easier for passenger car, truck, bus, farm tractor and aircraft tires



Ascot No.	Mfg. No.	Handle No.	Length	Weight
425-35321	T34	T11CH	17"	4.8 lb.
425-35323	T35	T11CH	16-1/2"	5.5 lb.
425-35325	T36	T11CH	16-1/2"	5.8 lb.
425-35105	T34RH	Rubberhead Replacement		



GENERAL PURPOSE HAMMERS & WEDGES



FIBERGLASS HANDLE HAMMERS



Ascot No.	Mfg. No.	Handle No.	Length	Weight
426-35411	TG11B	TG11BH	16"	4.8 lb.
426-35417	TG33R	TG31H	16"	2.5 lb.

DUCK BILLED BEAD BREAKING WEDGES - WOOD HANDLED

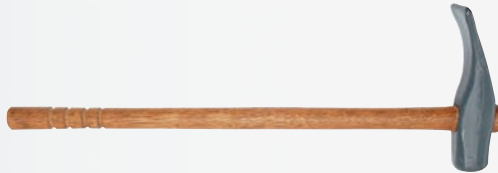

424-35329

Ascot No.	Mfg. No.	Handle No.	Length	Weight
424-35327	T11D	T11DH	17"	4.8 lb.
424-35329	T11E	T11EH	30"	9.2 lb.

DUCK BILLED BEAD BREAKING WEDGES - FIBERGLASS HANDLED



424-35429

Ascot No.	Mfg. No.	Handle No.	Length	Weight
424-35427	TG11D	TG11DH	18"	4.8 lb.
424-35429	TG11E	TG11EH	32"	9.1 lb.



TIRE KNOCKER

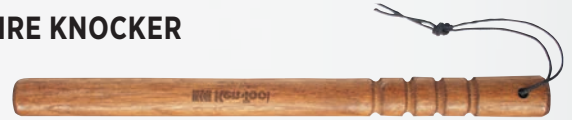

Ascot No.	Mfg. No.	Handle Length	Weight
426-35110	35110	18"	.7 lb.

FIBERGLASS REPLACEMENT HANDLES



Ascot No.	Mfg. No.	For Hammer No.	Length	Weight
429-35206	TG31H	TG11R, TG31, TG33R	16"	1 lb.
429-35211	TG11BH	TG11B	16"	1.3 lb.
429-35219	TG11CH	TG11C, TG34, TG35, TG36	18"	2.5 lb.
429-35218	TG11DH	TG11D	18"	1.2 lb.
429-35832	TG11EH	TG11E	32"	2.3 lb.

HICKORY REPLACEMENT HANDLES



Ascot No.	Mfg. No.	For Hammer No.	Length	Weight
429-35111	T11BH	T11B	15"	.75 lb.
429-35113	T11HN	T11R, T31, T33R	15"	.75 lb.
429-35119	T11CH	T11C, T34, T35, T36	17"	.75 lb.
429-35127	T11DH	T11D	17"	.75 lb.
429-35129	T11EH	T11E	30"	1.2 lb.

WRENCHES & LUG WRENCHES



KENTOOL PORKCHOP™ WRENCHES

- Holds outer cap nut on dual wheels while turning inner nut
- Lip fits in hole to secure wrench in place
- Fits standard and metric cap nuts



406-30609

Ascot No.	Mfg. No.	Description	Size	Weight
406-30609	TX9	SAE	1-1/2"	.4 lb.
406-30610	TX10	Metric	35mm	.4 lb.
406-30612	TX12	Metric	41mm	.4 lb.



HANDS FREE BUDD NUT WRENCHES

- Eliminates the need for hand and foot aid in separating the nuts, therefore reducing needless injury
- Reduces the work and potential for back strain because there is no need to lay down the tire
- Will not lose its grip on the outer cap nut so there is no loss of torque, which will give the impact wrench maximum power and efficiency



The Budd Nut Wrench in use.

COMBINATION CAP NUT WRENCHES

- Combination wrench offers you the versatility of two wrenches in one
- Fit one end onto the outer cap nut with other end through center hole
- Slides underneath center disc of wheel reducing slipping during nut removals



406-30620

Ascot No.	Mfg. No.	Description	Size	Weight
406-30620	TX50	SAE & Metric	41mm	1.3 lb.



406-60300

Ascot No.	Mfg. No.	Description
406-60300	60300	Budd Nut Wrench

HEAVY DUTY NUT WRENCHES

- Heavy duty design will not slip out of position
- Rests snugly against the center hole reducing the possibility of rim damage
- Great for aluminum rims



406-30618



Ascot No.	Mfg. No.	Description	Size	Weight
406-30618	TX200	SAE	1-1/2"	2.6 lb.
406-30619	TX241	Metric	41mm	2.6 lb.

BUDD NUT WRENCHES

- New design won't slip out of rim hole
- Will not damage aluminum/chrome rim
- Holds outer cap nut securely
- This adaptation of an old product solves the problem of damage to wheels, as well as broken toes and injuries to the feet
- Model 60301 has a replaceable polymer covered tail that locks the tool securely in place



406-60301

406-60302

406-60303

Ascot No.	Mfg. No.	Description
406-60301	60301	Budd Nut Wrench
406-60302	60302	Budd Nut Wrench - 35mm
406-60303	60303	Budd Nut Wrench - 41mm
406-60908	60908	Replaceable Polymer Tail





HEAVY DUTY TRUCK FOUR-WAY LUG WRENCHES

• **Drop-forged center** • **APPLICATIONS:** Heavy duty truck, bus, tractor four-way • Center hole for leverage bar • T96 with heavy duty solid center



403-35595



403-35695



403-35696



403-35697

Ascot No.	Mfg. No.	Length	Stock	Socket Size	Weight
403-35595	TC95	27-1/2"	1"	1-1/2", 13/16" Sq., 30, 33mm	14.2 lb.
403-35695	T95	27-1/2"	1"	1-1/16", 1-1/4", 1-1/2", 13/16" Sq.	13.8 lb.
403-35696	T96	27-1/2"	1"	1-1/16", 1-1/4", 1-1/2", 13/16" Sq.	13.5 lb.
403-35697	T95A	27-1/2"	1"	1-1/4", 1-1/2", 13/16" Sq., 3/4" Service Arm (will take any standard 3/4" drive socket)	13.5 lb.
403-35795	TM95	27-1/2"	1"	24, 27, 30, 33mm	13.5 lb.

STOW & GO™ 4-WAY HD LUG WRENCH

• The Stow & Go™ 4-Way HD Lug Wrench folds to save space in your trunk and locks into place for easy use • Push button in center allows wrench to fold after use • Sliding arms give extra leverage for removing lug nuts • Made of heavy duty and durable alloy steel • 17mm, 19mm, 21mm sockets, and 1/2" square drive adaptor to be used with other sockets • 16" in length

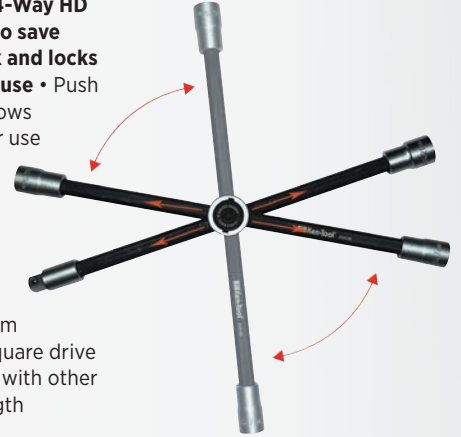

403-35636



The Stow & Go™ 4-Way HD Lug Wrench in use.

Ascot No.	Mfg. No.	Description
403-35636	35636	Stow & Go™ 4-Way HD Lug Wrench



WRENCHES & LUG WRENCHES



HEAVY DUTY TRUCK WRENCHES

- Use for off-the-road Budd-type wheels • Use TR11 handle



405-34401

Ascot No.	Mfg. No.	Length	Stock	Weight
405-34401	TR10	29-1/2"	1-3/4" Hex x 15/16" Square	12.2 lb.
402-34402	TR11	30"	1-1/4"	6.5 lb.

POWER WRENCH

- Designed for dual nut systems • Has 13/16" square end to hold inner nut, with a 1-1/2" hex drive to spin outer nut off



406-34547



The Budd Wheel Set in use.

Ascot No.	Mfg. No.	Description
404-34543	TR43	BASIC SET INCLUDES: Power Drive And Two Handles (Solid Bar - 20-1/2" Long And Tube - 20" Long)
404-34545	TR44X	BUDD WHEEL SET INCLUDES: Power Drive, One Bar, One Tube Handle, A 3/4" Service Adapter And One 13/16" Square Adapter
404-34547	TR44SW	UNIVERSAL SET INCLUDES: Power Drive, One 20-1/2" Bar, One 36" Tube Handle, A 3/4" Service Adapter, A 13/16" Square Adapter, And Six 3/4" Impact Sockets (7/8", 15/16", 1-1/16", 1-1/8", 1-3/16", 1-1/2")

DOUBLE END TRUCK WRENCHES

- Double end truck wrenches for on-the-road service • Sizes available for all standard lug nuts • Constructed from 1" high quality steel for greatest strength and durability • All will take our standard TR5 (ASCOT Order No. 405-32318) leverage handle • HANDLE HEX OPENING: 3/4" • LENGTH: 16"; WEIGHT: 4-1/2 lb.



402-32508

Ascot No.	Mfg. No.	Socket Size	Weight
SAE			
405-32501	TR1	1-1/8", 13/16" Square, 1-1/2"	4.6 lb.
405-32502	TR2	1, 1-1/4", 5/8" Square	4.3 lb.
405-32504	TR2X	15/16", 7/8"	4.5 lb.
405-32503	TR3	7/8", 1-1/16"	4.5 lb.
405-32505	TR3A	1-1/8", 1-1/16"	4.5 lb.
405-32506	TR3X	1-1/16", 1-3/16"	4.5 lb.
405-32509	TR9	1-1/4", 1-1/16"	4.5 lb.
405-32508	TR98	1-1/2", 13/16" Square	4.5 lb.
METRIC			
405-32551	TRM1	35mm Sq. x 17mm Square	4.5 lb.
405-32552	TRM2	24mm x 33mm	4.4 lb.
405-32553	TRM3	27mm x 30mm	4.5 lb.
405-32556	TRM6	41mm x 21mm Square	4.5 lb.
405-32557	TRM7	33mm x 30mm Square	4.5 lb.

DUAL WHEEL LUG STUD REMOVER

- Special self-tapping splines provide maximum grip to remove stripped lug studs • Use with TR1 and TR98 truck wrenches • Also used with open end wrench • Use with soft-faced hammer

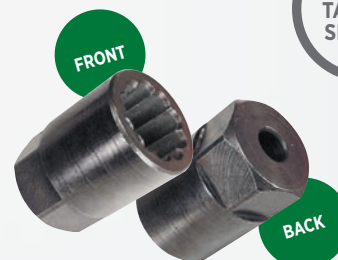

492-30165

Ascot No.	Mfg. No.	Description	Weight
492-30165	30165	Fits 13/16" Sq. Inner Nut	1 lb.

SHOP SERVICE TOOLS



DUAL WHEEL SEPARATOR

- **Makes removing stuck or frozen dual steel wheels quick and easy** • Ideal for use on nearly any truck, bus, van or trailer with dual steel wheels • Innovative “one-piece” pusher won’t fall apart during use • Forcing screw and pullers have powerful 1-1/8” diameter x 7 threads for years of reliable service • Pusher is ball bearing-driven for near-zero turning resistance • Pusher is heat treated for long-lasting strength and durability
- *Includes two pullers to cover large truck, trailer and smaller light truck dual wheel applications*
- Use with air or electric impact wrench • Blow molded case

422-94549



Ascot No.	Mfg. No.	Description
422-94549	ASC94549	Dual Wheel Separator



DUAL WHEEL SEPARATOR

- **Makes removing stuck or frozen dual steel wheels quick and easy**
- **APPLICATIONS:** Ideal for use on nearly any truck, bus, van or trailer that has dual steel wheels • **WEIGHT:** 6.5” x 9.5” x 2.5”, 5.3 lb. • **MADE IN USA**



422-34549



Ascot No.	Mfg. No.	Description
422-34549	34549	Dual Wheel Separator



TRUCK WHEEL & RIM REMOVAL TOOL

- **The easiest & quickest way to loosen stubborn, locked up rims** • Retire that back-breaking 20 lb sledge that you use to break seized rims apart • Eliminate damaged tire side walls and rims • Fits all standard (22.5 and 24.5) semi truck rims; aluminum or steel • Safe and efficient



QUICK AND EASY

422-71650

Ascot No.	Mfg. No.	Description
422-71650	71650	RIMWIT - Truck Wheel & Rim Removal Tool - Fits Standard 22.5 & 24.5 Wheels
422-71655	71655	RIMWIT JR- Truck Wheel & Rim Removal Tool - Fits 19.5” Wheels



SHARK FIN DUAL WHEEL SEPARATION BAG

- The first wheel separation solution for steel, aluminum and chrome wheels
- No metal on metal contact • 5000 lb. of static pressing force • Works on 15” to 24.5” dual and single wheels and tires on trucks & trailers • Kevlar inner inflation bag is industrial grade and nearly puncture proof • **SMALL BUT MIGHTY:** Portable, durable, and fast • Full inflation only takes a matter of seconds • 3-foot inflation hose makes access easy and safe
- Deflation is controlled with a quick turn of the slotted valve cap • 9.75” x 8” x 3/8” height deflated, 5.5” height when fully inflated • 90 psi max pushing pressure, 150 psi maximum rated pressure

NO METAL ON METAL CONTACT



429-36455

Ascot No.	Mfg. No.	Description
429-36455	364555	Shark Fin™ Dual Wheel Separation Bag

AUTOMATIC TIRE INFLATION SYSTEMS



All systems feature an operating range of 5-145 PSI, accurate within 0.3 PSI. Units are housed in weather resistant aluminum casings. All provide an easy to use and affordable way to assure precise inflation. Units available with 110 volt AC electric or battery hook up. Optional heater available for outdoor units. Custom faceplates with corporate logo and color available. Can be hardwired and mounted to mobile service trucks. Systems confirm calibration every six minutes when in use and everytime they are powered on. **INTERNATIONAL PROTECTION RATING:** IP66, provides complete weather protection (except submersions). Automatically inflates or deflates to target PSI when attached to tire position. All systems can be programmed to specific PSI parameters to help organizations better manage consistent and accurate tire inflation. Wirelessly receives/transmits gauged and corrected pressure via Bluetooth, Zigbee, or hardwired to PC. Designed to be operated with specific Haltec air chucks. **NITROGEN COMPATIBLE:** PSI is PSI, accuracy is main goal. All systems allow technician remote control of inflation/deflation process, keeping themselves out of "blast zone" of tire.



SINGLE TIRE INFLATOR

- Ideal for vehicle service centers, automobile dealerships and rental facilities • 1/4" inlet/outlet • **OPERATING RANGE:** 5-145 PSI



475-89001

HIGH VOLUME TIRE INFLATOR

- For Fleet Operations, Service Centers, or Mounters • **APPLICATIONS:** For 19.5" and larger rims • Capable of inflating four 22.5" tires from 5 to 100 PSI in 5 minutes



475-89003

Ascot No.	Mfg. No.	Description
475-89003	89XDB	High Volume Tire Inflator

Ascot No.	Mfg. No.	Description
475-89001	89XDA	Single Tire Inflation System

SINGLE TIRE INFLATION HOSES & ACCESSORIES



475-01898

478-00820

OVER INFLATION & HIGH VOLUME INFLATION SYSTEM

- For Retreaders, Fleets or Mounters • Inflate single or multiple tires to a preset over-pressure setting • Unit then performs a leak test for "zipper leaks" • Deflates to final preset required PSI setting • Features 3 preset PSI settings



475-89004

Ascot No.	Mfg. No.	Description
475-00896	SVL-STD	4' Mounting Steel Swivel Stand
475-01892	89HKC-L	Straight Hose w/Coupler & CH3600P Chuck
475-01893	89HKC-LC	Coil Hose w/ Coupler and CH-3600P Chuck
475-01894	89HKT-L	Straight Hose w/Coupler & CH 330-LO-OP Chuck
475-01895	89HK1-25	Straight Hose w/Coupler & IN-20 Tool
475-01896	89-2 WASV	2 Way Automatic Switching Valve (2 Hoses)
475-01897	89-3 WASV	3 Way Automatic Switching Valve (3 Hoses)
475-01898	89-3 WTK	3 Way Automatic Switching Valve Kit
478-00820	IN20	Core Removal and Inflation Tire Chuck

Specify Hose length when ordering. Components available separately.



Over Inflation Settings Target PSI



3 Programmable PSI Presets Remote Start Emergency Deflation

Ascot No.	Mfg. No.	Description
475-89004	89 XDZ	Over Inflation & High Volume System



FOUR-TIRE INFLATION/ EQUALIZER SYSTEM

- The Four-Tire Inflation System will inflate, deflate, and equalize up to four tires at once
- Engineered for maximum air volume and the highest possible accuracy
- Ensures repeatable and consistent tire inflation for every shop bay
- Helps prevent blowouts and tire decapitation
- Increases fuel mileage and saves tread life
- On/off toggle valves
- Accurate regulator system for drive axles
- Fast inflation times due to internally maximized hoses and ports
- Side mounted hose hangers
- Telescoping handle
- Four color-coded air hoses
- One panel-mounted, high flow regulator
- One panel-mounted, highly accurate air gauge



- UP TO 4 TIRES AT ONCE
- FOUR COLOR-CODED AIR HOSES
- TIRE SPECIFIC TOGGLE VALVES

Ascot No.	Mfg. No.	Description
475-09062	9062	Four-Tire Inflation/Equalizer System

MULTIPLE TIRE INFLATION SYSTEM (3-WAY)

- **Inflates up to three wheels simultaneously at a 5-145 PSI pressure**
- Semi-pneumatic locking swivel wheel
- Color-coded 0.25" inflation hose
- 1/2" and 3/8" inlet/outlet
- Suitable for use with standard or large bore valves and core extraction tools
- Inlet pressure gauge
- Dual LCD screens indicate gauged and targeted pressure



- INFLATES UP TO THREE WHEELS
- DUAL LCD SCREENS

Ascot No.	Mfg. No.	Description
475-89103	89MTIS-3DS	Haltec Multiple Tire Inflation System (3-Way)

AUTOMATIC TIRE INFLATION SYSTEMS



478-00360



478-00891



478-00892



478-00894



478-00895



478-03300

MULTIPLE TIRE INFLATION HOSES & ACCESSORIES

Ascot No.	Mfg. No.	Description
478-00360	CH-360S	Chip-On Style Air Chuck (Closed) w/Spring
475-00891	89HKC-LM	Straight Hose w/ CH-360S Air Chuck
475-00892	89HKT-LM	Straight Hose w/Coupler & CH-330-LO Air Chuck
475-00893	89HKI-25	Straight Hose w/Coupler & IN-20 Tool (Single Tire)
475-00894	89-HMVN	4-Way Manifold
475-00895	89-3W	Air Flow Control Valve
475-00896	SVL-STD	4' Mounting Steel Swivel Stand
478-03300	CH-330-LO	Lock-On Style Air Chuck (Dual Wheels)

4-WAY INFLATOR ACCESSORY BLOCK

- Lightweight aluminum manifold splits air lines into (4) separate lines
- Slide valve turns air on/off to start inflation
- (4) 1/4" universal quick couplers allow for any type fitting
- 3' whip hose



477-11624

Ascot No.	Description
477-11624	4-Way Inflator Accessory Block



477-11623



4-WAY INFLATOR KIT

- Quick coupler connects directly to the inflator
- Slide valve allows air supply to be turned on & off
- Includes all hoses and connection

Ascot No.	Mfg. No.	Description
477-11623	11.0623NA	4-Way Inflator Kit - 25ft
477-11625	11.0625NA	4-Way Inflator Kit - 10ft

MISC TIRE SERVICING TOOLS



417-39120
Blue (Fine)

417-39121
Maroon
(Medium)

417-39122
Brown
(Coarse)

417-13004
Maroon (Medium)



**417-13003,
417-13005**
Brown (Coarse)



417-13007
3" Maroon (Medium)

417-13006
3" Brown (Coarse)



417-16211
3" Strip Brite Pad

417-16210
2" Strip Brite Pad

2" QUICK CHANGE SURFACE CONDITIONING DISCS

- Available in fine, medium or coarse
- Embedded with abrasive grain to eliminate fraying of edges, resist loading and provide a consistent finish
- Ideal for flat or contoured surfaces
- **Made in USA**

Ascot No.	Mfg. No.	Description
417-39120	3912BLUEF	2" Quick Change Surface Conditioning Discs: Blue (Fine)
417-39121	3912MARNM	2" Quick Change Surface Conditioning Discs: Maroon (Medium)
417-39122	3912BRWNC	2" Quick Change Surface Conditioning Discs: Brown (Coarse)
417-13003	620TE-1	2" Surface Conditioning Discs: Brown (Coarse)
417-13004	622TE-1	2" Surface Conditioning Discs: Maroon (Medium)
417-13005	620TE-1-50	2" Surface Conditioning Discs: Brown (Coarse)

3" QUICK CHANGE SURFACE CONDITIONING DISCS

- Features the quick and easy "R" type backing
- Ideal for general grinding, rust removal, clean-up and paint removal
- Use with right angle or die grinders
- Ideal for flat contoured surfaces
- **Made in USA**

Ascot No.	Mfg. No.	Description
417-13006	630TE	3" Quick Change Surface Conditioning Discs
417-13007	632TE	3" Quick Change Surface Conditioning Discs

3" STRIP-BRITE PADS

- Feature the quick and easy twist-to-lock attachment system
- Provide aggressive and long lasting performance
- Durable, three-dimensional web with a soft edge in unreachable creases and dents without damaging metal
- **Made in USA**

Ascot No.	Mfg. No.	Description	Qty
417-16210	16210	2" Strip-Brite Pad - Purple (Coarse)	10/box
417-16211	16211	3" Strip-Brite Pad - Purple (Coarse)	10/box

MISC TIRE SERVICING TOOLS



GREEN ZIRCONIA DISCS

- Twist-to-lock backing
- Offers longer life and more aggressive results than zirconia or aluminum oxide
- Flexible discs resist chipping, snagging and cracking
- 20,000 RPM
- For use on air grinders and are compatible with all 3M style, Type "R" backing pads
- Especially good on extra hard metals
- 25 per box
- **Made in USA**

Ascot No.	Mfg. No.	Description	Qty
417-12612	12612	2" Green Zirconia Grinding Disc - 24 Grit	25/box
417-12613	12613	2" Green Zirconia Grinding Disc - 36 Grit	25/box
417-12614	12614	2" Green Zirconia Grinding Disc - 50 Grit	25/box
417-12615	12615	2" Green Zirconia Grinding Disc - 80 Grit	25/box
417-12616	12616	3" Green Zirconia Grinding Disc - 24 Grit	25/box
417-12617	12617	3" Green Zirconia Grinding Disc - 36 Grit	25/box
417-12618	12618	3" Green Zirconia Grinding Disc - 50 Grit	25/box
417-12619	12619	3" Green Zirconia Grinding Disc - 80 Grit	25/box



417-12618
3" Green Zirconia Disc

417-12613
2" Green Zirconia Disc

BACKING PADS FOR SURFACE CONDITIONING DISCS

- Compatible with all twist-to-lock brands of discs
- Rigid rubber pad
- Twist-to-lock attachment
- Use with surface prep, mini grinding, strip-it and mini flap discs

Ascot No.	Mfg. No.	Description
417-39202	13012	Backing Pad for 2" Surface Conditioning Discs
417-39203	13013	Backing Pad for 3" Surface Conditioning Discs

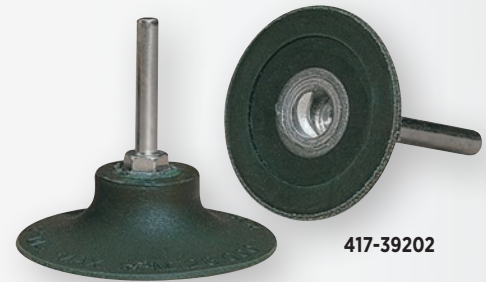

417-39202

CUT-OFF WHEELS

- Reinforced with fiberglass
- Fast cutting abrasive can be used in a variety of applications, including steel cutting
- The fiberglass reinforcement provides greater tensile strength, as well as safety
- **Made in USA**

Ascot No.	Mfg. No.	Description
417-12704	12704	3" Cut Off Wheels (10 Pack)



417-12704
Cut-Off Wheels

MINI ANGLE DIE GRINDER KIT

- **KIT INCLUDES:** (1) 2" backing pad, (2) 2" coarse surface prep pads, (2) 2" medium surface prep pads, (2) 2" fine surface prep pads, (2) 2" 50 grit sanding discs, (2) 2" 36 grit sanding discs, (2) 2" 24 grit sanding discs packed in a heavy duty carrying case
- **MAX RPM:** 22,500

Ascot No.	Mfg. No.	Description
157-01875	CP875K	Mini Angle Die Grinder Kit



157-01875
Mini Angle Die Grinder Kit



SAFETY INFLATION CAGES



KEN-TOOL® SAFETY INFLATION CAGES

- Constructed of heavy gauge steel welded to a steel base
- Guards against blown lock rings, exploding rims and ruptured tire explosions when used properly
- These cages meet OSHA safety requirements (29-CFR Part 1910.177)



Ascot No.	Mfg. No.	Description	Handles Tires	Base Plate	Inside Height	Inside Dimensions	Weight
2-BAR SAFETY INFLATION CAGES							
479-46001	36001	2-Bar Safety Cage	—	7" x 21-1/2"	41"	41" H x 16" W	60 lb.
479-46011	36007	2-Bar Wide Base Safety Cage	—	7" x 27"	43.5"	43.5" H x 20.5" W	72 lb.
3-BAR SAFETY INFLATION CAGES							
479-36003	T103	3-Bar Safety Cage/Light Truck Cage	—	21-1/2" x 22"	30"	30" H x 16" W	80 lb.
479-36004	T104	3-Bar Safety Cage for Off Road	—	30" x 27"	65"	65" H x 24" W	158 lb.
479-46006	36006	3-Bar Tire Inflation Cage	—	31.5" x 26"	43.5"	43.5" H x 20.5" W	146 lb.
4-BAR SAFETY INFLATION CAGES							
479-46002	36002	4-Bar Safety Cage	—	31.5" x 26"	43.5"	43.5 H x 20.5 W	146 lb.
5-BAR SAFETY INFLATION CAGES							
479-46005	36005	5-Bar Safety Cage	—	41" x 26"	43.5"	43.5" H x 20.5" W	182 lb.
479-46010	36010	5-Bar Super Magnum	—	48" x 30"	41.5"	41.5" H x 24" W	248 lb.



Work safely. Always use an inflation cage when inflating tires.
Follow OSHA regulation 29-CFR Part 1910.177 whenever changing tires.

SAFETY INFLATION CAGES



BRANICK SAFETY INFLATION CAGES

• Constructed of heavy gauge steel welded to a steel base • No-mar wheel protection available • Multiple sizes for passenger and commercial locations • Side mesh option provides complete protection • Arch design for maximum energy displacement • These cages meet OSHA safety requirements (29-CFR Part 1910.177)

2-BAR



479-02220

3-BAR



479-02130

4-BAR



479-02240

6-BAR



479-02260



Ascot No.	Mfg. No.	Description	Max. Height x Max. Tire Width	Dimensions	Weight
2-BAR SAFETY INFLATION CAGES					
479-02220	2220	Portable 2-Bar Safety Cage	54" x 21.5"	28" W x 17" D x 60" H	76 lb.
3-BAR SAFETY INFLATION CAGES					
479-02130	2130	3-Bar Passenger/Light Truck Cage	34" x 21.5"	28" W x 20" D x 40" H	120 lb.
4-BAR SAFETY INFLATION CAGES					
479-02240	2240	4-Bar Safety Cage with No Mar Coating	54" x 21.5"	28" W x 28" D x 60" H	170 lb.
6-BAR SAFETY INFLATION CAGES					
479-02260	2260	6-Bar Safety Cage	59" x 29"	35" W x 41" D x 62" H	385 lb.



Work safely. Always use an inflation cage when inflating tires. Follow OSHA regulation 29-CFR Part 1910.177 whenever changing tires.



ASCOT SUPPLY SAFETY INFLATION CAGES

- A safety inflation cage is mandatory in any shop for tubeless and multi-piece rims and Ascot offers a size and design for all your needs
- Constructed of heavy gauge steel welded to a steel base
- Guards against blown lock rings, exploding rims and ruptured tire explosions when used properly
- These cages meet OSHA safety requirements (29-CFR Part 1910.177)



HEAVY GAUGE STEEL

VARIOUS SIZES AND DESIGNS

Ascot No.	Mfg. No.	Description	Handles Tires	Dimensions	Weight
2-BAR SAFETY INFLATION CAGES					
479-36001	MIC-2	Portable 2-Bar Safety Cage	Up to 48" OD X 13" W	21-1/2" x 16-3/4" x 51"	69 lb.
479-36011	MIC-2WB	Portable 2-Bar Safety Cage (Super Single)	Up to 48" OD X 21" W	29" x 16-3/4" x 52"	78 lb.
479-36201	MIC-2G	Galvanized Portable 2-Bar Safety Cage	Up to 48" OD X 13" W	21-1/2" x 16-3/4" x 51"	69 lb.
479-36211	MIC-2WBG	Galvanized Portable 2-Bar Safety Cage (Super Single)	Up to 48" OD X 21" W	29" x 16-3/4" x 52"	78 lb.
3-BAR SAFETY INFLATION CAGES					
479-36006	MIC-3	3-Bar Safety Cage	Up to 47" OD X 19" W	22-1/4" x 26-1/4" x 57-5/16"	108 lb.
479-36013	MIC-PCR	3-Bar Passenger-SUV Safety Cage	Up to 35" OD X 12.5" W	21" x 28" x 40"	93 lb.
4-BAR SAFETY INFLATION CAGES					
479-36002	MIC-4	4-Bar Safety Cage	Up to 47" OD X 19" W	31-5/8" x 26-1/4" x 57-5/16"	147 lb.
5-BAR SAFETY INFLATION CAGES					
479-36005	MIC-5	5-Bar Safety Cage	Up to 47" OD X 19" W	41" x 26-1/4" x 57-5/16"	182 lb.
479-36015	MIC-OTR	OTR 5-Bar Safety Cage	Up to 62" OD X 33" W	41" x 39-3/8" x 66"	277 lb.



Work safely. Always use an inflation cage when inflating tires. Follow OSHA regulation 29-CFR Part 1910.177 whenever changing tires.

SAFETY INFLATION CAGES



TRUCK TIRE CHANGING STAND

• **APPLICATIONS:** Handles wheels or open rims 16.5" to 24" • Double-slide adjustment with locking device prevents twisting so it stays aligned with the wheel or rim • Ideal height for driving off beads or demounting tire



Ascot No.	Mfg. No.	Description
479-36115	T115	Truck Tire Changing Stand

EZ TIRE ROTATOR FOR INFLATION CAGES

• **APPLICATIONS:** EZ Tire Rotator fits any Ken-Tool 3-Bar, 4-Bar and 5-Bar Inflation Cage, plus many competitive cages • No need to lift or remove rim/wheel assembly from cage when repositioning valve stem for access through the cage tubes • Allows tire tech to easily and quickly rotate rim/wheel assembly inside the safety cage in order to adjust position of valve stem • Reduces handling, back strain and user fatigue; increases safety • Easily installed or moved to another cage - no fastening required • No assembly required; simply place in the center of the cage • Features heavy-duty 2" ball-bearing steel rollers and 1/4" thick steel stock for long service • Boxed and UPS shippable • **MADE IN USA**



ROLLER FOR TIRE INFLATION CAGES

• **Used to roll the tires easily directly into the inflation cage** • Allows an easy access to the tire valve because it is easy to turn the tire to have the valve to any position • For use with all 3-bar, 4-bar & 5-bar inflation cages • Prevent back injuries when handling heavy tires • **WEIGHT:** 12 lbs.



Ascot No.	Mfg. No.	Description
479-36014	T114	EZ Tire Rotator for Inflation Cages

Ascot No.	Mfg. No.	Description
479-36111	MIC-ROLLER	Roller for Tire Inflation Cages

TPMS TOOLS



DILL TRAILER TPMS SYSTEMS

- Dill's aftermarket Trailer TPMS is available in 2-wheel and up to 10-wheel combinations
- 4 optional valve stems that attach to the sensors are available for different wheel styles
- Protect the goods you tow, Increase fuel economy and extend tire life

UP TO
10 WHEEL
COMBOS

INCREASE
FUEL
ECONOMY

EXTEND
TIRE
LIFE



The display on the Dill Trailer TPMS System.



469-04416

Ascot No.	Mfg. No.	Description
469-02453	1502-453	Trailer TPMS Kit, Two (2) Wheels, 0.453" Rim Hole Diam.
469-04416	1504-416	Trailer TPMS Kit, Four (4) Wheels, 0.453" Rim Hole Diam.
469-04572	1504-572	Trailer TPMS Kit, Four (4) Wheels, 0.625" Rim Hole Diam.
469-06453	1506-453	Trailer TPMS Kit, Six (6) Wheels, 0.453" Rim Hole Diam.
469-06572	1506-572	Trailer TPMS Kit, Six (6) Wheels, 0.625" Rim Hole Diam.
469-08453	1508-453	Trailer TPMS Kit, Eight (8) Wheels, 0.453" Rim Hole Diam.
469-08572	1508-572	Trailer TPMS Kit, Eight (8) Wheels, 0.625" Rim Hole Diam.
469-10453	1510-453	Trailer TPMS Kit, Ten (10) Wheels, 0.453" Rim Hole Diam.
469-10572	1510-572	Trailer TPMS Kit, Ten (10) Wheels, 0.625" Rim Hole Diam.

TUBELESS TIRE VALVES (TRUCK)



TRUCK & BUS TUBELESS TIRE VALVES: 570 SERIES

- Used on both demountable and non-demountable rims with standard 5/8" (.625") side hole valve mountings
- Heavy duty rubber grommet forms airtight seal when valve is clamped in rim by tightening the hex nut
- Eight valves cover all truck rim requirements
- Available in custom bends
- Dill or Haltec equivalent available

Ascot No.	TR No.	Effective Length
463-00575	575	1-1/8"
463-00501	501	1-1/2"
463-00500	500	2"
463-00570	570	3-1/8"
463-00571	571	3-3/8"
463-00572	572	3-3/4"
463-00573	573	4-3/8"
463-00574	574	5"



463-00500

REPLACEMENT VALVE COMPONENTS

- Packaged 100 per Box

Ascot No.	Dill No.	Description
468-00103	100-TB	Dill Replacement Core
468-00462	462G	Dill Green High Temp Grommet
468-00765	765	Dill Replacement Dome Cap
468-01462	462-F	Dill Red High Temp Grommet (-50F to 400F)
468-02462	462	Dill Black Rubber Grommet
468-05952	595-2	Replacement Washer
468-05953	595-3	Replacement Grommet
468-05954	595-4	Replacement Hex Nut

TUBELESS VALVES FOR ALUMINUM DISC WHEELS

- For drop-center aluminum disc wheels with 5/8" bottom valve hole

Ascot No.	TR No.	Effective Length
463-00509	509	4-3/4"
463-00510	510	5-1/2"
463-00511	511	4-1/4"
468-05093	509-3	Replacement Rubber Grommet



463-00500

NITROGEN O-RING & SLEEVES

- Fits 540 and 570 Truck Valves
- Nitrogen use in truck tires

Ascot No.	TR No.	Description
468-00307	TS-OR	O-Ring
468-00607	NITSLV	Indicator Sleeves



468-00307 468-00607

ALUMINUM WHEEL TRUCK TUBELESS TIRE VALVES: 540 & 550 SERIES

- Designed for use with 9.7mm (.382") rim hole
- Rubber O-ring forms a seal when valve is clamped to rim by tightening hex nut
- Designed specifically for use in aluminum wheels
- Dill or equivalent available
- 550 Series equipped with rubber grommet

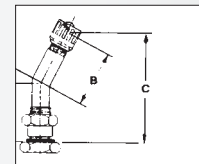

Ascot No.	TR No.	A	B	C
540 SERIES				
463-00542	542	1.25"	—	—
463-00543	543	2.31"	—	—
463-00544	544	2.86"	—	—
463-00545	545	3.50"	—	—
463-00546	546	4.25"	—	—
463-01544	544C	0.86"	1.94"	45°
463-05433	543C	0.93"	1.43"	45°
463-05434	543D	0.98"	1.38"	60°
463-05435	543E	0.98"	1.38"	75°
463-05444	544D	0.98"	1.94"	60°
463-05454	545D	0.98"	2.60"	60°
463-05464	546D	0.98"	3.35"	60°
463-05465	546E	0.98"	3.35"	75°
463-05474	547D	0.98"	3.78"	60°
463-15454	545E	0.98"	2.60"	75°
463-54636	546-36	0.98"	3.35"	36°
468-10060	RG-60	Repl. O-Ring TR-540 Series		



463-01555

Ascot No.	TR No.	A	B	C
550 SERIES				
463-00552	552	1.25"	—	—
463-00553	553	2.31"	—	—
463-01553	553C	0.93"	1.43"	45°
463-02553	553D	0.98"	1.38"	60°
463-03553	553E	0.98"	1.38"	75°
463-03554	554C	.98"	1.94"	45°
463-02554	554D	0.98"	1.94"	60°
463-01555	555D	0.98"	2.60"	60°
463-02555	555E	0.98"	2.60"	75°
468-10070	RG-70	Grommet for 550 Series		

METRIC RIM HOLE VALVES (9.7MM VALVE HOLE)

- Some imported trucks will have steel wheels that incorporate the 9.7mm valve hole (.382")
- Most popular valves for this application
- Other sizes available upon request

Ascot No.	MFG No.	ETRTO	Bend	A	B
462-04100	41 MS-00	V3-20-1	STR	1-3/16"	—
462-06027	60 MS-27	—	27°	1-3/16"	1-3/16"
462-07025	70 MS-27	V3-20-5	27°	1-3/16"	1-9/16"
462-08027	80 MS-27	V3-20-7	27°	1-3/16"	2"
462-09027	90 MS-27	V3-20-4	27°	1-3/16"	2-3/8"
462-11527	115 MS-27	V3-20-6	27°	1-3/16"	3-3/8"
468-00707	70 MS-7	—	7°	—	—



462-09027

468-00707

TRUCK & SPECIALTY VALVES



RADIAL COMMANDER VALVE FOR 15" DISC WHEELS

• **23° bend clamp-down valve for .625" valve hole** • Bend allows clearance of brake drum for tire service • *Cap and core not included*

Ascot No.	Mfg No.	Description
462-01147	VS-1223R	Radial Commander Valve. Made in the USA.
462-01224	VS-1224	Longer Radial Commander Valve for Equal Applications

462-01224

TUBELESS MOTORCYCLE VALVE

• **Has O-ring seal** • Fits .327" valve holes
• **EFFECTIVE LENGTH: 1-13/16"**

Ascot No.	Mfg No.	Description
462-00430	TR-430	Tubeless Motorcycle Valve

462-00430

VALVE FOR 16 X 6KS WITH OVAL HOLE

• **Oval rim slot valve for 16 x 6KS and 16 x 6-1/2LS rim contours** • Allows a positive seal in this special valve hole • *Check the valve hole for metal burrs prior to installation*

Ascot No.	Mfg No.	Description
462-05010	H5010V	Oval Rim Slot Valve

462-05010

ALLOY VALVE

• **Light alloy valve used on racing and light alloy wheels** • Fits .453" valve hole • Has O-ring seal

Ascot No.	Mfg No.	Description
462-00523	H-523MS	Alloy Valve

462-00523

TRUCK/BUS SCREW-ON REPAIR VALVES

• **Replace damaged cured-in or cured-on valves without cutting out old valve base** • 1-1/16" horizontal diameter

Ascot No.	Mfg No.	Effective Length
463-01177	1177A	3-3/4"
463-01175	1175A	4-1/2"
463-01078	1078A	5"

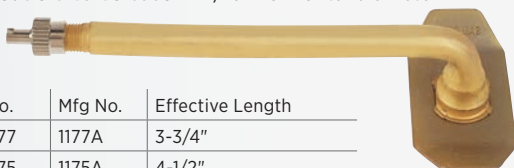
463-01078

SPECIAL CLAMP-IN TIRE VALVE

• **Designed for front wheel drive Toronado ('66-'78) and Eldorado ('67-'78) cars**

Ascot No.	Mfg No.	Description
462-00417	417	Special Clamp-In Tire Valve

462-00417

FORD "F" SERIES TRUCK VALVE



• **Ford F-Series Trucks with inner dual wheels** • Sealing metal cap • 0.453" valve hole • Torque 25-45 inch/lbs.

Ascot No.	Mfg No.	Description
462-00962	VS-962C	Ford "F" Series Truck Valve

462-00962

TRACTOR FRONT WHEEL VALVES

• **Low profile valve offers minimum protrusion above the rim** • 9/16" effective length with chrome finish • Fits .453" or .625" valve holes

Ascot No.	Mfg No.	Description
462-06008	TV-6008C	Tractor Front Wheel Valve With Chrome Finish
462-16008	TV-6008	Tractor Front Wheel Valve With Brass Finish

462-06008

FORD "F" SERIES TRUCK VALVE



• **Ford "F" series with dual wheels** • Accuride steel 16" x 16"
• Front and rear wheels • Nickel finish • *Includes dual seal cap*

Ascot No.	Mfg No.	Description
462-02416	TV-416MC	Ford "F" Series Valve

462-02416



FORD "F" SERIES TRUCK VALVE

- Ford "F" series with dual wheels • Alcoa aluminum 16"
- Front and rear wheels • Chrome finish • Includes dual seal cap

Ascot No.	Mfg No.	Description
462-01600	N-1600	Ford "F" Series Truck Valve



462-01600

FORD "F" SERIES VALVE

- Ford "F" series with dual wheels • Accuride steel 19.5"
- Front and rear wheels • Nickel finish • Includes dual seal cap

Ascot No.	Mfg No.	Description
462-03416	TV-416/DS-1	Ford "F" Series Valve



462-03416

FORD "CUT-AWAY" SERIES VALVE

- Ford "cut-away" series with dual wheels • Accuride steel 16" x 16"
- Front and rear wheels • Nickel finish • Includes dual seal cap

Ascot No.	Mfg No.	Description
462-01416	TV-416LF	Ford "F" Series Valve



462-01416

FORD "CUT-AWAY" AND CARGO VAN SERIES VALVE

- Ford "cut-away" and Cargo van series with single rear wheels
- Accuride steel 16" x 7" wheels • Front and rear wheels • Chrome Finish

Ascot No.	Mfg No.	Description
462-01575	TV-575HP/DS-1	Ford "Cut-Away" & Cargo Van Series



462-01575

TRUCK & SPECIALTY VALVES



O-RING SEAL SILICONE TRUCK VALVES

- Handles any type of high temp application • Operating temperature from -67° F to 500° F • Seals between the rim and valve more effectively • **REPLACEMENT O-RINGS AVAILABLE: RG-150 (468-30015)**



469-02572

463-01572

Ascot No.	Mfg. No.	Description
463-01571	VS-571-EQ	O-Ring Silicone Truck Valve for TR571
463-01572	VS-572-EQ	O-Ring Silicone Truck Valve for TR572
463-01573	VS-573-EQ	O-Ring Silicone Truck Valve for TR573
469-02570	VS-570EQ	O-Ring Silicone Truck Valve for TR570
469-02572	VS-572EQ-13	O-Ring Silicone Truck Valve for TR572 - 13° Bend
469-02573	VS-573EQ-13	O-Ring Silicone Truck Valve for TR573 - 13° Bend

STANDARD O-RINGS FOR TUBELESS RIMS

- Made of high quality polysoprene rubber • Packaged 2 per poly bag, 24 O-rings per case • Manufactured to major OEM specifications • **Made In USA**



Ascot No.	Mfg. No.	Rod Diam.	Size
471-80008	OR-25-T	0.26"	EM 25"
471-80007	OR-224-TG	0.26"	Grader 24"
471-80012	OR-33-T	0.385"	EM 33"
471-80010	OR-325-T	0.385"	EM 25"



NUT SPLITTER

- Removes brass tire valves from truck rims
- Available in manual and pneumatic



Ascot No.	Mfg. No.	Description
469-00580	NS58B	Manual Nut Splitter
469-00590	NS59B	Pneumatic Nut Splitter. Attaches To Pneumatic Hammer



VALVE BREAKER

- Removes valves quickly
- Slide hammer with an internal spring absorbs the shock of impact
- Easy to use
- Designed to shear the bottom flange off the valve with one or two blows



Ascot No.	Mfg No.	Description
469-35934	35934	27" Valve Breaker
469-32011	35936	45" Valve Breaker
469-32012	35935	Valve Breaker Parts Kit

VALVE BLASTER TRUCK VALVE STEM REMOVAL TOOL

- Removes valves quickly
- Slide hammer with an internal spring absorbs the shock of impact
- Easy to use
- Designed to shear the bottom flange off the valve with one or two blows
- OAL - 63"



Ascot No.	Mfg. No.	Description
469-22011	VB	Valve Blaster Truck Valve Stem Removal Tool
469-22012	RE	Replaceable End for Valve Blaster Truck Stem Removal Tool



VALVE STEM WRENCH KIT

- Kit includes 9/16" & 5/8" valve stem wrenches in durable pouch



Ascot No.	Mfg. No.	Description
469-01820	VSW-1820-KIT	Valve Stem Wrench Kit
469-00018	VSW18	Valve Stem Wrench
469-00020	VSW20	Valve Stem Wrench

TRUCK & SPECIALTY VALVES



SLIMLINE VALVE NUT TORQUE WRENCH

- **OPERATING RANGE:** 40-180 in./lbs. (4-20 Nm)
- **ACCURACY:** +/- 4%
- The SLO Torque Wrench is the smallest wrench in our 'Slimline' range
- Perfect for TPMS applications
- Traceable calibration certificate supplied to satisfy ISO 9000 quality systems
- High quality 72-tooth ratchet allows use in confined spaces
- Production 'P' Type versions designed to discourage unauthorized alteration
- Wide variety of end fittings available, to suit most applications
- Unmistakable signal when set torque is reached
- *Ends sold separately and not included with 11126 Torque Wrench*



168-11126



The 16mm Spigot Adjustment on Norbar's Slimline Valve Nut Torque Wrench.

The ends shown are sold separately and are not included with the 11126 Torque Wrench



VALVE NUT TORQUE WRENCHES

- **Wrench flexes when proper torque setting is reached**
- Prevents overtightening of the valve grommet
- Cushioned handle
- Sizes and preset torque settings laser etched on shaft
- 9/16" for TR570 series valve hex nuts
- 5/8" for TR540-550 series valve hex nuts
- +/- 4% accuracy



168-00916

168-00058

Ascot No.	MFG. No.	Description
168-11126	11126	Slimline Valve Nut Torque Wrench

AVAILABLE ENDS FOR SLIMLINE VALVE NUT TORQUE WRENCH

168-29706	29706	9/16" Open End
168-29731	29731	9/16" Ring End
168-29756	29756	9/16" Flare End
168-29707	29707	5/8" Open End
168-29732	29732	5/8" Ring End
168-29757	29757	5/8" Flare End



Ascot No.	Mfg. No.	Description
168-00916	NSPTW916	9/16" Preset Valve Torque Wrench - 42 in./lb.
168-00058	NSPTW58	5/8" Preset Valve Torque Wrench - 100 in./lb.

DILL TRUCK VALVE TOOL KIT

- **Tool Kit for alloy and steel truck wheels**
- Allows you to accurately inspect, gauge and install truck valves with pre-set torque tools
- Follows industry guidelines and valve hole measurements
- Included industry-recognized truck valve stem installation procedures poster is 34" x 22" in size and is printed on heavy poster paper with gloss

PARTS INCLUDED:

540G & 570G Go/No-Go Gauges
T-540 & T-570 Preset Torque Wrenches

572G-6 T-Handle Hex Tool to hold base of stems
Industry-Recognized Truck Valve Stem Installation Procedures Poster



469-05700

FOR ALLOY
& STEEL
TRUCK
WHEELS

PRE-SET
TORQUE
TOOLS



469-15720

INDUSTRY-
RECOGNIZED
TRUCK
VALVE STEM
INSTALLATION
PROCEDURES



469-05720

Ascot No.	Mfg. No.	Description
469-05700	5700	Dill Truck Valve Tool Kit w/ 2 Open-End Torque Tools
469-05720	5720	Dill Truck Valve Tool Kit w/ 1 Open-End and 1 Straight Torque Tool
469-15720	5720-Poster	Wall Poster of Accurate Truck Valve Installation and Inspection Processes



VALVE CAPS, CORES & EXTENSIONS



TRUCK VALVE CAPS



468-00102



468-00632



468-00765

Ascot No.	Mfg. No.	Description	TR No.	Sealing Washer Material	Operating Pressure	Operating Temp Range (F)	Pack Size	Finish
468-00765	765	Dill Dome Cap	VC3	Nitrile	0-200 PSI	-40° To +165°F	100	Nickel Plated
468-00632	632	Dill High Temp Dome Cap	VC3	Plastic	100 PSI	-40° To +250°F	100	Nickel Plated
468-00102	6300V	All Purpose Cap With Screwdriver Top For Removing/ Inserting Valve Cores	VC2	Nitrile	0-200 PSI	-40° To +165°F	100	Nickel Plated

DOUBLE SEALING VALVE CAPS

- Light weight design uses both high temperature and low temperature resistant airtight seals at extension tip and valve mouth
- External grooves accommodate all industry standard air chucks and gauges
- Knurled surface for easy hand installation
- Nickel plated for better appearance and improved corrosion protection
- Brass or plated, grooved or knurled
- Increases productivity
- **MADE & TESTED IN THE USA**



468-26541



468-16541



Ascot No.	Mfg. No.	Description	Qty./Box
468-06541	6541N	Double Seal Valve Cap	50
468-16541	6541N	Double Seal Valve Cap	250
468-26541	6541N2	Double Seal Cap for Nitrogen	250



DUAL WHEEL EXTENSIONS

- For convenient air service access to inner rear dual wheels
- Fit standard valve cap threads and include a clip to secure the extension to the wheel cutout
- Can be used on campers, recreational vehicles and light trucks



468-10012

Ascot No.	Mfg. No.	Eff. Length
468-10017	9059-7	7"
468-10019	9059-9	9"
468-10011	9059-11	11"
468-10012	9059-12	12"



DOUBLE SEAL CAP

- A time, money and labor saving alternative to common valve caps
- Reduce pressure check time by 65%
- Designed for high pressure truck tire service
- Inflate, deflate or gauge directly thru the DS-1 saving time during inflation and pressure checks
- Automatic inflation systems lock right onto the DS-1
- Seals like a high pressure cap, yet offers the convenience of an inflate thru extension
- Performs like a check valve, the seal becomes tighter in the event of a core failure
- Heat resistant grommets provide additional protection for extended high temperature running
- Features tough all metal housing, precision fit brass components and durable self-sealing O-Ring



468-04191

Ascot No.	Mfg. No.	Description
468-04191	DS-1	Double Seal Cap



ALLIGATOR V2B DUAL SEAL CAP

- Made in Germany by Alligator
- Increased tire life
- Lower fuel consumption
- Safety for driver and vehicle



468-02222

Ascot No.	Mfg. No.	Description	Qty./Box
468-02222	V2B-50	Alligator V2B Dual Seal Cap	50
468-12222	V2B-250	Alligator V2B Dual Seal Cap	250

DILL TRUCK VALVE EXTENSIONS

• Extensions screw onto the standard .305" valve cap threads of the valve stem and make valve mouth accessible for air service • Available in various lengths

Ascot No.	Mfg. No.	Eff. Length
STRAIGHT METAL EXTENSIONS		
468-00330	330	4-1/8"
468-00331	331	3-1/8"
468-00341	341	4-7/16"
468-00346	346	1"
468-00347	347	3-1/16"
468-00348	348	5-1/16"
468-00349	349	6-1/16"
468-00350	350	2-7/32"
468-00356	356	1-13/32"

Ascot No.	Mfg. No.	Bend Angle	Eff. Length
BENT METAL EXTENSIONS			
468-08028	8028	45°	1-3/8"



468-00347

DILL LIGHTWEIGHT TRUCK VALVE EXTENSIONS

• Made from nickel plated brass • Provide the additional length necessary to inflate, deflate or gauge tires with valves hidden by decorative wheel covers • Lightweight

Ascot No.	Mfg. No.	Collar Type	Eff. Length
468-01032	1032	Short 3/8"	2"
468-01033	1033	Short 3/8"	2.93"
468-01034	1034	Short 3/8"	3.93"
468-01035	1035	Short 3/8"	5.12"
468-01037	1037	Long 1"	2.93"
468-01038	1038	Long 1"	5.12"
468-01039	1039	Long 1"	6"



468-01038



468-01039

HALTEC ALUMINUM EXTENSIONS

• Extremely lightweight
• Made from aluminum



Ascot No.	Mfg. No.	Collar Type	Eff. Length
468-01390	HE-390A	Long	2"
468-01391	HE-391A	Long	2-15/16"
468-01392	HE-392A	Long	5-1/8"
468-01393	HE-393A	Long	6"



468-01390

DUAL WHEEL FLEXIBLE VALVE EXTENSIONS

• Provide easy access to the inner dual tire found on campers, recreational vehicles and light trucks • Fit standard valve cap threads • Come with clamp to secure extension to wheel cutout • 2 extensions per pack and available in steel braided hose



468-30007

468-40007

Ascot No.	Mfg. No.	Description	Eff. Length
468-30007	FE-300-7	Flexible Extension	7"
468-30010	FE-300-9	Flexible Extension	9"
468-40007	SFE-400-7	Steel Braided Extension	7"
468-40010	SFE-400-10	Steel Braided Extension	10"
468-90597	9059-7	Reinforced Rubber Hose	7"
468-90599	9059-9	Reinforced Rubber Hose	9"
468-95911	9059-11	Reinforced Rubber Hose	11"

VALVE ACCESSORIES

Ascot No.	TR. No.	Fits Thread	For Uses On
HEX NUTS			
468-10013	HN-13	.406"-28	TR570 Series
468-10004	HN-4	.406"-28	TR416
468-10117	HN-17	.406"-28	TR509, 510
468-00808	RW-8	.406"-28	TV500 & TV570 Series
GROMMETS			
468-10015	RG-15	.625"	TR570 Series
468-11700	G-170S	.625"	Heat Resistant for TV570
468-10046	RG-46	.625"	TR509, 510
468-10039	RG-39	.625"	TR416
468-10054	RG-54	.453"	TR416
O-RING			
468-10060	RG-60	.328"	TR540 Series



468-10015



468-10046



468-10060

SPECIAL APPLICATION PRODUCTS



HALTEC TRUCK VALVE EXTENSIONS

- **HE-370 SERIES:** Lightweight Extensions have the short collar for use on tube-type valves or tubeless lightweight valves. Has a double seal feature to assure positive seal
- **HE-390 SERIES:** Lightweight Extensions are the same as the HE-370 series except with a long collar
- **HE-380 SERIES:** Standard Style Extensions screw on the standard valve stem (.305"-32" cap thread) and make valve mouth accessible
- *Extensions & stabilizers available for Alcoa wheels*

Ascot No.	Mfg. No.	Collar Type	Eff. Length
468-00370	HE-370	Short 3/8"	2"
468-00371	HE-371	Short 3/8"	2-15/16"
468-00372	HE-372	Short 3/8"	3-15/16"
468-00373	HE-373	Short 3/8"	5-1/8"
468-00389	HE-389	Long 1"	1-1/16"
468-00390	HE-390	Long 1"	2"
468-00391	HE-391	Long 1"	2-15/16"
468-00392	HE-392	Long 1"	5-1/8"
468-00393	HE-393	Long 1"	6"
468-00394	HE-394	Long 1"	8"
468-00395	HE-395	Long 1"	10"
468-00396	HE-396	Long 1"	12"
468-00397	HE-397	Long 1"	14"
STANDARD STYLE			
468-00381	HE-381	Long 1"	3-1/16"
468-00382	HE-382	Long 1"	5-1/16"
468-00383	HE-383	Long 1"	6-1/16"

468-00370



468-00390

468-00382



468-13530



468-13531

BLACK POLYMER VALVE EXTENSIONS

- **Light-weight truck extensions are made of a durable, tough plastic able to withstand the conditions tire valve extensions are exposed to**
- They are designed for use where vibration and weight is a concern for valve stem breakage

Ascot No.	Mfg. No.	Cap	Eff. Length
468-13500	HE-350	VC-3	2.04"
468-13501	HE-350D	DS-1	2.63"
468-13510	HE-351	VC-3	3.82"
468-13511	HE-351D	DS-1	4.41"
468-13520	HE-352	VC-3	5.21"
468-13521	HE-352D	DS-1	5.80"
468-13530	HE-353	VC-3	5.94"
468-13531	HE-353D	DS-1	6.53"



CROSSFIRE DUAL™ TIRE PRESSURE EQUALIZATION SYSTEM

HOW CROSSFIRE WORKS: Crossfire is a pressure equalizing and monitoring valve that is mounted between dual tires. It bolts easily to the lug, hub cap, or drive axle end. Properly mounted, air freely flows from one tire to the other, maintaining equal tire pressure and load distribution.

- **Maximizes tire life**
- Decreases rolling resistance for increased fuel mileage
- Cuts maintenance time due to single-point inflation and the visual pressure gauge
- Improves stability, braking and overall safety
- Installs in minutes and requires little maintenance
- Pays for itself in less than a year
- **American-made and guaranteed for two years**



Under-inflation
20% under-inflation can cause a minimum 30% loss of tire life expectancy



Over-inflation
20% over-inflation can cause a minimum 10% loss of tire life expectancy



Proper-inflation
Mounted correctly, Crossfire's yellow indicator verifies that air is flowing freely from one tire to the other, equalizing the load

Mfg. No.	Description
CF-PSI-RH	Crossfire Rubber Hoses
CF-PSI-HD	Crossfire Heavy Duty Hoses
CF-PSI-ST	Crossfire Stainless Steel Hoses
SS-PSI-RH	Super Single Rubber Hoses
SS-PSI-ST	Super Single Steel Hoses



Crossfire valves are available for desired air pressures of 50 to 150 PSI in 5 PSI increments.

Example: **CF-100-ST** = Crossfire valve, 100 PSI air pressure, stainless steel hose with AT & BH brackets.



VALVE HARDWARE TOOLS



VALVE INSERTION AND REMOVAL TOOLS



Ascot No.	Mfg. No.	Description
469-00014	VT-014	Valve Installation Tool with Rubber Block
469-00040	00040R	Valve Stem Puller with Rubber Boot
469-00992	992	Tubeless Tire And Tire Valve Inserting And Removing Tool. For All Sizes Of Snap-In Passenger Car Tire Valves
469-01124	VT-1124	Tubeless Tire Valve Service Tool. Pull-A-Stem Tool Pulls Old Valves Or Inserts New Valves. Tool Fits All Sizes Or Lengths
469-03333	VT-03P	Plastic Valve Puller with Metal Rod Insert

VALVE CORE INSERTION AND REMOVAL TOOLS



Ascot No.	Mfg. No.	Description
469-00001	CT-1	Pocket-Size Valve Core Remover
469-00003	CT-3	Heavy Duty Standard Valve Core Remover
469-00005	CT-5	For Both Standard and Large Bore Valves
469-00607	607	Has Plastic Screwdriver Handle For Better Grip And Leverage, Made in USA
469-01638	1638A	Heavy Duty Professional Plastic Valve Puller. Steel Tube Reinforced Handle Provides Extreme Rigidity. Safety Orange Color For Easy Visibility. Protects Wheels From Damage During Installation/Removal Of Snap-In Valve Stems
469-15407	15407	Angled Tubeless Tire Valve Inserting And Removing Tool

STANDARD BORE VALVE TOOLS



Ascot No.	Mfg. No.	Description
469-00612	TL-612	Standard Bore Core Tool. With An Overall Length Of 8" And Oversized Handle
469-00625	TL-625	Standard Bore Core Tool. With Recessed Probe. Fits In Pocket
469-00630	TL-630	Hex Nut Driver. For 500 Series Truck. For Tubeless Clamp-In Metal Valves. For All Lengths of Tubeless Truck Valves
469-00632	TL-632	Truck Extension Service Tool. Tightens Both Metric European And Domestic Type Extensions. Broached To Engage The Metric Hex At The Extension Top and Will Reach The Hex On A 7" U.S.A. Type Extension
469-00633	TL-633	Valve Cap Tool. Easy To Remove And Install Valve Caps On Inside Dual Wheels. For Aluminum Wheels
469-00006	CT6-10	<ul style="list-style-type: none"> • STANDARD BORE VALVE CORE TOOL • Has a plastic screwdriver handle for better grip and leverage • 10 Pack



SUR-LOCK VALVE TOOLS

• **Special design allows the valve core to stay attached to the tool after it is removed from the valve** • Great tool to keep the valve core from getting dropped or lost

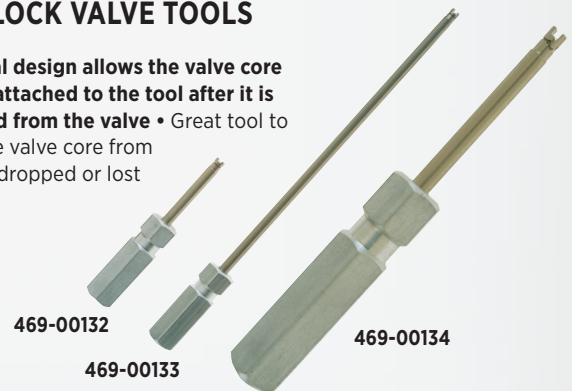

Ascot No.	Mfg. No.	Description
469-00131	TL-131	For Bicycles
469-00132	TL-132	For Cars. 1-3/4" Length
469-00133	TL-133	For Trucks. 8-1/4" Length
469-00134	TL-134	For Large Bore Cores. 10-1/2" Length



VALVE HARDWARE TOOLS



VALVE AND CORE TOOLS

Ascot No.	Mfg. No.	Description
469-00002	CT-2	Black Heat Treated Heavy Duty Tire Valve Repair Tool. 4-in-1 Standard Valve Tool Repairs Cap Threads, Repairs Core Threads. Easy-Out Feature For Removing Damaged Cores & Removing Standard Caps
469-00004	CT-4	Economy Standard Bore 4-Way Tool
469-00011	VT-11	Cable Valve Fishing Tool. Valve Core Wrench And Deflating Pin With Flexible Cable For Fishing Valve Through Rim Hole
469-00018	VSW18	Valve Stem Ratchet. For TR570 Series Valves
469-00020	VSW20	Valve Stem Ratchet. For TR540 Series Valves
469-00021	VT-21	Double-Use Tool. Removes Valve Cores. Screws On Valve Mouth To Open Core
469-00081	TVT-81	Heavy Duty 4-Way Valve Core Tool
469-00567	567A	Core Removing Tool. Screwdriver Grip. Easy Out For Removing Broken Cores
469-00609	TL-609	Chain Valve Fishing Tool. Guides Valve Smoothly Through Rim Hole While Mounting Tire & Tube
469-01115	VT-1115	Valve Core Tool. For Inserting And Removing. Valve Cores. Long Hex Body For Easy Access
469-05262	5262	Tube Deflating Aspirator. Screwing Aspirator Onto Valve Mouth And Applying Air Chuck To Threaded Inlet Creates Vacuum That Siphons Air From Tube
469-11115	VT-1115I	Recessed Valve Core Tool. Core Tool Is Recessed Into The Handle. Design Eliminates The Possibility Of The Tool Poking Through A Shirt Pocket. Easily Fits Into A Shirt Pocket. Includes Clip
469-23430	VG8	Tube Deflator. Removes Air Completely, Quickly After The Valve Core Is Moved. Fits On Every Type Of Standard Bore Valve
469-32850	3285D	Lock-On Screwdriver Core Tool. 5" Effective Length. Allows The Valve Core To Stay Attached To The Tool After It Is Removed From The Valve. Protects The Valve Core From Loss. Aluminum Handles Provide A Sturdy Grip For Inserting And Removing Valve Cores
469-32851	3285E	Lock-On Screwdriver Core Tool. 6.5" Effective Length. Allows The Valve Core To Stay Attached To The Tool After It Is Removed From The Valve. Protects The Valve Core From Loss. Aluminum Handles Provide A Sturdy Grip For Inserting And Removing Valve Cores
469-52000	S-2	Valve Capper Inner Dual Valve Core/Cap Tool
469-00673	673-D	Screwdriver/Core Tool. Lock-On Feature For The Valve Core. Metal Pocket Clip. Flat-Head Screwdriver Tip



469-00002



469-00004



469-00021

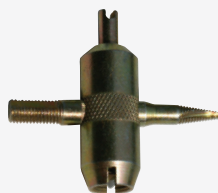

469-00081



469-05262



469-23430



469-00011

469-00018/
469-00020

469-00567



469-00609



469-00673

469-01115



469-11115



469-32850

469-32851



469-52000

TIRE GAUGES



BRAKE LINING THICKNESS GAUGE

- Made of durable metal • Each blade features both SAE and Metric measurements • Clear and accurate depth readings for a quick and easy reading • Color coded brake gauge provides effective identification • THE SET IS DIVIDED INTO 3 COLORS: Red, Yellow and Green • Red 2 mm (.787") Brakes must be serviced • Yellow 4 mm (.1575") Brakes must be serviced • Made in Taiwan



411-97840



411-65201

Ascot No.	Mfg. No.	Description
411-97840	BG-97840	3-Piece Brake Lining Thickness Gauge
411-65201	B650201	8-Piece Brake Lining Thickness Gauge

TRUCK SERVICE GAUGES

- Wide variety of service gauges to accommodate the numerous tire and wheel configurations encountered by tire service personnel
- Available in chrome plated or protective black epoxy finish as indicated • Calibrated from 10-150 PSI in 2-pound increments • Nylon or metal indicator bars

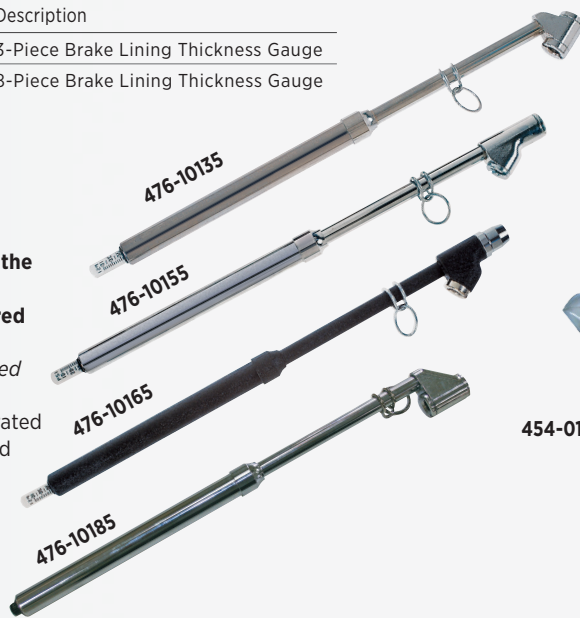

Ascot No.	Mfg. No.	Description
476-10480	1048T	Dual Chuck Service Gauge, Straight-On/ Angled With Metal Bar, Black Epoxy Finish
476-10135	GA-135	Angle Chuck With Nylon Bar
476-11135	GA-135S	Same As Above, Angle Chuck With Metal Bar
476-10155	GA-155	Straight-On With 30° Reverse Chuck
476-10165	GA-165	Same As Above, Straight-On With 30° Reverse Chuck, Black Epoxy Finish
476-11148	1048S	Dual Straight Service Gauge, Short Length
476-11155	GA-155S	Same As Above, Straight-On With 30° Reverse Chuck, Metal Bar
476-11048	1048-ADJ	Internal Adjustable Field Service Gauge
476-10185	GA-185	Dual Foot Service Gauge With Nylon Bar, 180° Chuck, Chrome Plated
476-11185	GA-185S	Same As Above, Dual Foot Service Gauge With Metal Bar

TIRE TREAD DEPTH GAUGES



454-00190

454-00599

454-00712



454-01420

454-01599

454-05127

Ascot No.	Mfg. No.	Description
454-00190	HT-190L	3-Color All-Metal Tread Depth Gauge
454-00599	595	Tire Tread Depth Gauge. Used To Measure Tire Tread Depth In 1/32" Increments: 0-1"
454-00712	NS712	All Metal Tread Depth Gauge
454-01420	HT-1420	Truck Tire Depth Gauge. Calibrated In mm and 1/32nd of Inch. Measures Shoulder Wear and Tread Depth. Durable Metal Construction
454-01599	599-C	3-Color Tread Depth Gauge
454-05127	5127	Red-Yellow-Green Metal indicator bar with black numbers 0-32In 32NDS



TIRE GAUGES



DIGITAL TREAD DEPTH GAUGE

- Made from strong carbon fiber composite
- Zero setting in any position
- Metric, decimal inch and fraction inch toggle
- Large LCD display



454-00209



The Digital Tread Depth Gauge in use.

Ascot No.	Mfg. No.	Description
454-00209	NS209S	Digital Tread Depth Gauge

DIGITAL TRUCK TIRE GAUGE

- OPERATING RANGE: 0-180 PSI
- RESOLUTION: 0.5 PSI • ACCURACY: +/- 1% + 0.5 PSI at 100 PSI
- Calibration in BAR, KG/CM 2, KPA and PSI
- Auto power off, simple operation
- Built-in backlight with clear, large LCD display
- Replaceable LED battery
- POWER SOURCE: Lithium & LR 44 Alkaline



478-03238

Ascot No.	Mfg. No.	Description
478-03238	N/A	Digital Truck Tire Gauge

DIGITAL POCKET GAUGE

- RANGE: 0-150 PSI in .5 PSI increments
- ACCURACY: ±1% PSI accuracy
- Large LCD display
- Red backlight
- Angled chuck head



476-32380

Ascot No.	Mfg. No.	Description
476-32380	3238P	Digital Pocket Gauge w/ Angle Chuck - 1-150 PSI



DIAL GAUGE

- Calibrated 0 to 160 PSI in 5 PSI units and 150 to 1100 in kPa metric scale
- 14" flexible hose
- Holds pressure readout until released



476-00274

Ascot No.	Mfg. No.	Description
476-00274	GA-274	Dial Gauge. 0 -160 PSI

DILL ADJUSTABLE TRUCK TIRE GAUGES

Ascot No.	Mfg. No.	Description
476-07125	7125H	Straight and 30 Degree Reverse, Chrome, White Nylon Bar
476-07233	7233	360 Deg. Swivel for Standard and Large Bore
476-07262	7262	Straight and 30 Degree Reverse, Black, Black Metal Bar
476-07275	7275RB	Adjustable Truck Service Gauge with 25 Degree Offset Angle Chuck (Internally Adjustable)
476-07285	7285R	Dual Foot Service Gauge With Reverse Angle Chuck (Internally Adjustable)
476-17275	7275RBE	Adjustable Truck Service Gauge with 25 Degree Offset Angle Chuck (Externally Adjustable)
476-17285	7285E	External Adjustable Truck Service Gauge
476-27275	7275	Dual Angle, Chrome, Black Metal Bar
476-37285	7285	Straight and 30 Degree Reverse, Chrome, Black Metal Bar



476-07275

476-17285

ADJUSTABLE FIELD SERVICE GAUGES

- **Field adjustable truck service gauges** • External Adjustment Screw makes calibration quick & easy • Adjustable Calibration
- Plated finish provides corrosion protection and great looks • 4-sided metal indicator bar is durable and easy to read • Hang-up ring provides a convenient method of storage • Flat-head screwdriver required for calibration

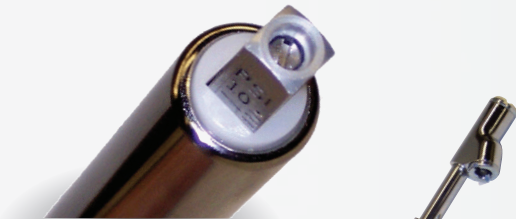

The External Adjustment Screw makes calibration quick & easy.

476-01046

476-11048



MASTER TEST GAUGE

- **For checking accuracy of service and pencil gauges** • Has dual foot chuck and a retaining valve to hold pressure reading after gauge is removed from valve to within +/- 2% of total dial reading • Includes protective case • **MADE IN THE USA**



Shown in included protective case



476-08860

Ascot No.	Mfg. No.	Description	Range
476-08860	8860C	Master Test Gauge	0 - 160 PSI

Ascot No.	Mfg. No.	Description
476-00135	135S-RCL	Adjustable Dual Foot Service Gauge
476-00165	165S-RCL	Adjustable Dual Foot Service Gauge
476-00185	185S-RCL	Adjustable Dual Foot Service Gauge -180 Degree Reverse Chuck
476-00250	250S-RCL	Adjustable Large Bore Pencil Gauge
476-00255	255S-RCL	Adjustable Large Bore Swivel Gauge
476-01046	1046-ADJ	Screwdriver Adjustable Calibration Gauge
476-11048	1048-ADJ	Internal Adjustable Metal Bar Gauge

CHECKING STATIONS



MASTER AIR GAUGE CHECKING STATIONS

- **INFLATION RANGE:** 0-200 PSI • **ACCURATE TO:** ±1 PSI • Designed to allow users to quickly and accurately check their air gauges and inflator gauges • **THREE CHECKING POINTS:** standard valve port, large bore valve port & female coupler port • Most accurate checking station on the market • Equipped with a regulator and filter for proper air and water filtration • CARB Certified • Back-lit readout for ease of use • Can be mounted to a bench or a wall



MOST ACCURATE CHECKING STATION

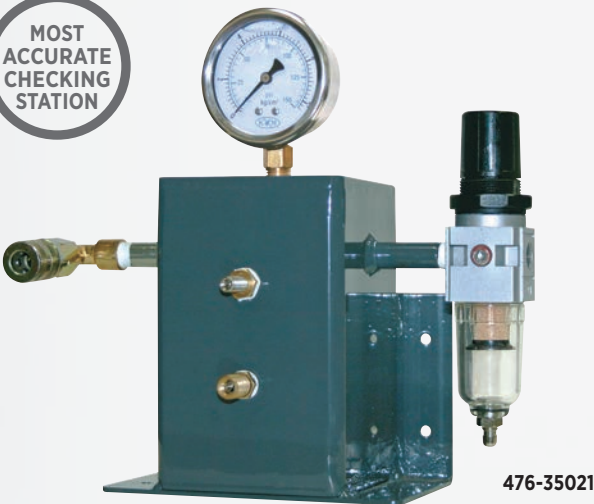

DILL AIR GAUGE CHECKING STATIONS

- A quick accurate way for tire dealers to check the accuracy of air gauges - a must for facilities that need to comply with California standards • 0-160 psi liquid filled gauge • Access valve mounted on a pressure reservoir • 1/4 inch NPT filter/regulator to remove contaminants from compressed air • A certificate of accuracy for ISO records • Designed to easily bolt to a wall or table • **MADE, TESTED & CERTIFIED IN THE USA**



EASILY BOLT TO WALL OR TABLE



QUICK & ACCURATE

Ascot No.	Mfg. No.	Description
476-35020	TS3502A	Digital Gauge Checking Station
476-35021	TS3502AL	Air/Liquid Gauge Checking Station

Ascot No.	Mfg. No.	Description
476-03502	3502	Replacement Digital Air Gauge
476-08500	8500	Dill Air Gauge Checking Station
476-08501	8500D	Dill Digital Air Gauge Checking Station
476-08900	8900	Replacement Dial Air Gauge (Fully Calibrated)



DILL USA GAUGES & CHUCKS

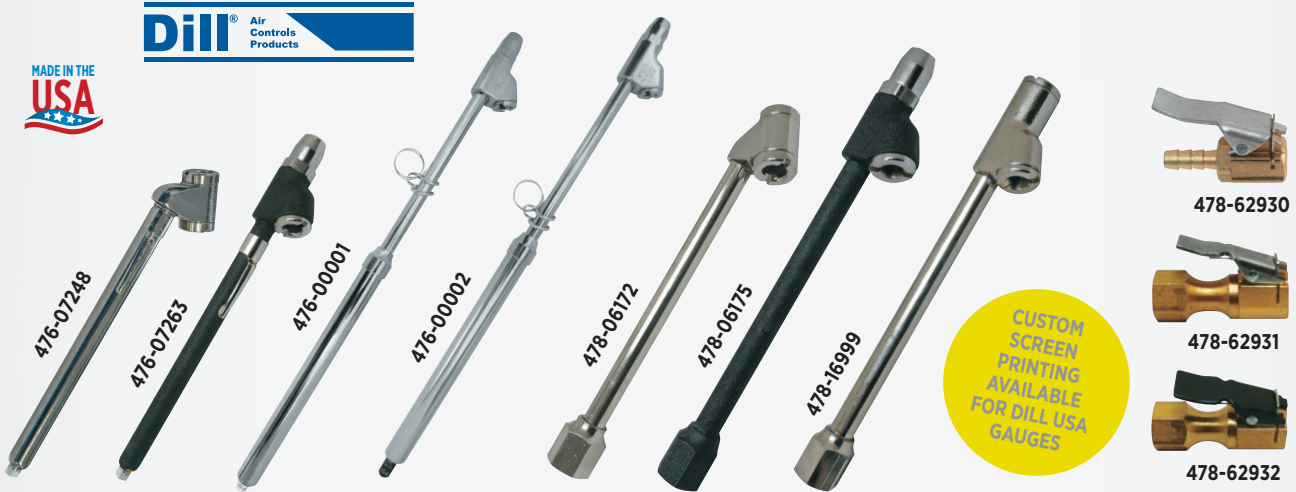

DILL USA DUAL FOOT TRUCK GAUGES

Ascot No.	Mfg. No.	Range	Description	Finish	Qty./Pack
476-07248	7248-USA*	20-120 PSI	Dual Angle Foot Chuck	Chrome	10
476-07263	7263-USA*	20-120 PSI	Straight-On 30° Reverse Chuck	Black Powder	10
476-07278	7278-USA*	20-120 PSI	Straight-On 30° Reverse Chuck	Chrome	10

DILL USA TRUCK SERVICE GAUGES

Ascot No.	Mfg. No.	Range	Description	Finish	Qty./Pack
476-00001	SG1	10-150 PSI	Dual Foot Head; Chrome Body with Black Markings on a White Bar	Chrome	1
476-00002	SG2	10-150 PSI	Dual Foot Head; Chrome Body with White Markings on a Black Bar - Adjustable	Chrome	1
476-00003	SG3	10-150 PSI	Dual Foot Head; Black Powder Coated Body with White Marking on a Black Bar - Adjustable	Chrome	1

* Denotes gauges meet the proposed California Regulation for Under Inflated Vehicle Tires No. 95550.

DILL USA AIR CHUCKS

Ascot No.	Mfg. No.	Length	Description	Finish	Qty./Pack
478-06172	6172-USA	6"	Angle Chuck for Inner Dual Wheels with Tilted Valves	Chrome	10
478-06173	6173-USA	6"	Lock Feature Straight-On 180° Degree Reverse Angle Chuck	Chrome	10
478-06174	6174-USA	14"	Extra Long Length Lock Feature Straight and 30° Reverse Angle Chuck	Chrome	10
478-16174	6174-BLK-USA	14"	Extra Long Length Lock Feature Straight and 30° Reverse Angle Chuck	Black Poly	10
478-06175	6175-USA	6"	Lock Feature Straight-On 30° Reverse Angle Chuck	Black Poly	10
478-06176	6176-USA	6"	For Standard Air Line Service	Chrome	10
478-06999	6999-USA	6"	Straight with 30° Reverse Angle Chuck	Chrome	10
478-16999	6999L-USA	6"	Same as 6999-USA Except for Lock-On	Chrome	10

DILL USA CLIP-ON AIR CHUCKS

Ascot No.	Mfg. No.	Connection	Description	Finish	Qty./Pack
478-62930	6293C-USA	5/16" Barbed Fitting	Straight Clip Chuck for European Type Tire Changer, Normally Open	Silver Clip	10
478-62931	6293D-USA	1/4" NPT Female	Straight Clip Chuck for European Type Tire Changer, Normally Open	Silver Clip	10
478-62932	6293E-USA	1/4" NPT Female	Straight Clip Chuck for European Type Tire Changer, Flow Through	Black Clip	10
478-62933	6293	1/4" NPT Female	Ball Foot Chuck, Normally Closed	Silver Clip	10
478-62934	6293A	1/4" NPT Female	Clip Only for 6293 & 6293B Clip-On Chuck	Silver Clip	10
478-62935	6293B	1/4" NPT Female	Ball Foot Chuck, Normally Open	Black Clip	10



AIR CHUCKS



DUAL FOOT AIR CHUCKS



Ascot No.	Mfg. No.	Description
478-00335	CH-335	Angled Chuck. Plated Finish (Normally Closed)
478-01330	6568-FT	Dual Foot Chuck. 1/4" FPT, 6" Long, Lock-On Threads (Normally Open)
478-01335	CH-335-OP	Angled Chuck. Plated Finish (Normally Open)
478-01350	CH-350-LO	Straight-On/Angled Chuck. Protective Black Epoxy Finish (Normally Closed)
478-01351	6568T-FT	Straight-On/Angled Chuck. Black Epoxy Finish (Normally Open)
478-03300	CH-330-LO	Straight-On/Angled Chuck. With Lock-On Threads (Normally Closed)
478-03301	CH-330	Straight-On/Angled Chuck (Normally Closed)
478-03330	CH-333-LO	Straight-On/Angled Chuck. 14" Long (Normally Closed)
478-03370	CH-370-LO	Straight-On/180° Chuck. 1/4" NPT (Normally Closed)
478-06585	6585LB	Large and Standard Bore Chuck. 1/4" NPT (Normally Closed)

ANGLE HEAD AIR CHUCKS

Ascot No.	Mfg. No.	Description
478-03238	3238P-C	Angle Head Air Chuck - Chrome Finish



BALL FOOT CHUCKS

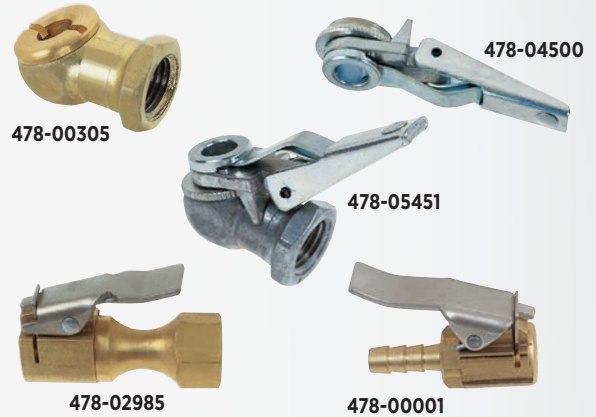

Ascot No.	Mfg. No.	Description
478-00305	CH-305	Ball Foot Chuck. 1/4" Female Thread (Normally Closed)
478-00315	CH-315	Ball Foot Chuck With Lock-on Clip. 1/4" Female Thread (Normally Closed)
478-00325	CH-325	Ball Foot Chuck With Lock-on Clip. 1/4" Female Thread (Normally Open)
478-05451	—	Ball Foot Chuck With Lock-on Clip. 1/4" Female Thread (Normally Closed - Alligator)
478-00707	—	Replacement Washer. For 478-05451 Ball Foot Chuck
478-04500	—	Air Chuck Clip. For All Ball Foot Chucks
478-04501	—	Economy Clip for Clip-On Ball Foot Air Chuck

EUROPEAN-STYLE CLIP-ON CHUCKS



Ascot No.	Mfg. No.	Description
478-00001	N-1200	European-Style Clip-On Chuck. Serrated Shank for 1/4" I.D. Hose. Silver (Normally Open)
478-02985	CH-360	European-Style Clip-On Chuck. 1/4" Female Fitting. Silver Clip (Normally Closed)
478-02995	CH-360-OP	European-Style Clip-On Chuck. 1/4" Female Fitting. Black Clip (Normally Open)
478-06293	6293-S	European-Style Clip-On Chuck. 1/4" Barbed Fitting. Straight Clip Chuck. Small Head Design. Silver Clip (Normally Open)

LOCK-ON AIR CHUCKS

Ascot No.	Mfg. No.	Description
478-00340	CH-340	Lock-On Air Chuck. 1/4" NPT Female Thread. Securely Locks Onto Valve When Sleeve Is Pushed Forward
478-01340	CH-340-OP	Lock-On Air Chuck. Available For Use With Tire Changers
478-05265	H-5265	Lock-On Air Chuck. Specially Designed To Lock Onto The Cap Of A Standard Bore Valve Stem When The Sliding Sleeve Is Pushed To Forward Position





REVERSE ANGLE LOCK-ON AIR CHUCK

- Reverse angle lock-on chuck allows easy access to outer dual valve



478-00345



Ascot No.	Mfg. No.	Description
478-00345	CH-345	Reverse Angle Lock-On Air Chuck (Normally Closed)
478-01345	CH-345-OP	Reverse Angle Lock-On Air Chuck (Normally Open)



TRUCK LOCK-ON EXTENSION CHUCK

- Extended reach for dual wheels
- Easy on/off application
- Steel pins for increased service life
- Automatic locking design
- Improves seal on flow through caps
- 22" overall length



478-00346



LONG REACH STRAIGHT LOCK-ON CHUCK

Ascot No.	Mfg. No.	Description
478-00346	CH-346	Long Reach Straight Lock-On Chuck (Normally Closed)
478-01346	CH-346-OP	Long Reach Straight Lock-On Chuck (Normally Open)



478-32072

EUROPEAN-STYLE CLIP-ON CHUCK

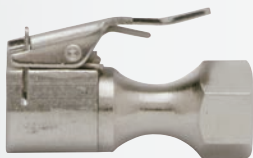

478-02975

Ascot No.	Mfg. No.	Description
478-02975	CH-360S	European-Style Clip-On Chuck. 1/4" Female Fitting - With Spring Loaded Deflector Pin

Ascot No.	Mfg. No.	Description
478-32072	32071-L2	Truck Lock-On Extension Chuck

AIR CHUCKS



LARGE BORE GAUGES



LARGE BORE AIR CHUCKS



Ascot No.	Mfg. No.	Description
454-01410	N-1410	Off-Highway Tire Tread Depth Gauge. Calibrated With 32nds And MM. Magnified Sight Glass For Easy Readability
454-05131	5131	Large Bore Tread Depth Gauge
454-05300	5300	Tire Tread Depth Gauge w/ Magnifying Lens - Calibrated with 32nds & MM
476-02555	GA255S-RCL	Recalibrateable Large Bore Swivel Gauge. Nickel Plated Brass. Metal Slide Bar. Calibrated 10-150 PSI in 2 lb. Units. Swivels 360° for Those Hard-to-Reach Valves
476-07233	7233	Dill Swivel Gauge
476-10240	GA-240	Straight-On Gauge. 20 - 120 PSI
476-10250	GA-250S	Swivel Gauge. Nickel Plated Brass. Plastic Bar. Calibrated 10 - 150 PSI In 2 lb. Units. Swivels 360° For Those Hard-To-Reach Valves
476-10255	GA-255S	Swivel Gauge. Nickel Plated Brass. Metal Slide Bar. Calibrated 10 - 150 PSI In 2 lb. Units. Swivels 360° For Those Hard-To-Reach Valves

Ascot No.	Mfg. No.	Description
478-00322	322	Large Bore Dual Foot Air Chuck. 45° Chuck For Easy Access To Valve. 1/4" NPT Female Thread
478-00326	326	Screw-On Air Chuck. .458"-26 Internal Thread. 1/2" NPT External Thread. Full Flow For Seating Of Tire Beads
478-00328	AC-B10	Short Lock-On Air Chuck. Locks On Valve When Cocked On Threads. Greater Air Flow And Seat Cannot Be Blown Out If Seal Fails. 1/4" NPT Thread
478-00377	AC-B11	Long Lock-On Air Chuck
478-04660	AC-B12	Clip-On Air Chuck. Locks Onto Valve When Sleeve Is Pushed Forward, Releases When Sleeve Is Pulled Back. 1/4" NPT Female Thread
478-06190	6190	Quick Connection Inflation Gauge. For Use With 6185 Check Valve. Sliding Sleeve Locks Chuck Onto Check Valve. Permits Unrestricted Air Flow
478-10013	10013	Large Bore Screw-On Chuck. Fits 3/8" ID Air Hose

INFLATOR GAUGES



RPG DIGITAL INFLATOR

- Auto on/off operation • **MAX INFLATION:** 174 PSI • Accuracy exceeds EC Standards • Multi-scale gauge • Serial/batch numbered • Backlit digital display • Wire sheathed hose eliminates kinking • Impact absorbing bumpers • Rubber grip on chuck
- Tough die cast aluminium body • 20" hose with hold-on chuck
- Quick and easy to use • *Includes certificate of calibration*



MULTI-GAUGE SCALE:

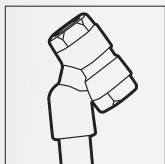

Dual Angle Chuck

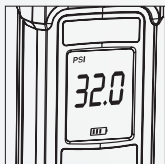

Multi-Scale Gauge

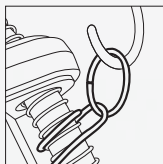

Hang Point

Ascot No.	Mfg. No.	Description
477-10312	10.3012RPG	Digital Inflator w/ 20" Hose and Hold-On Air Chuck



AUTOMATIC INFLATOR

- All the features of a wall mounted inflator in a portable hand held unit
- **BUILT-IN OVERPRESSURE SETTING FUNCTION:** OPS function that allows the tire to be inflated to a certain pressure then deflates automatically to a normal operating pressure, used to seat tires to rims
- Auto on/off operation • **MAX INFLATION:** 174 PSI • Accuracy exceeds EC Standards • Multi-scale gauge • Serial/batch numbered • Backlit digital display • Wire sheathed hose eliminates kinking • Tough poly carbonate/ABS body • Two programmable pre-set preset buttons • Fast and safe 5' hose with lock-on chuck • Built-in rechargeable lithium-ion battery • Up to 15 hours of continuous use • *Includes AC adapter for charging*
- *Includes certificate of calibration*



Ascot No.	Mfg. No.	Description
477-11612	11.0612NA	Automatic Inflator - 5' Hose w/ Clip-On Air Chuck



RPG DIGITAL TIRE INFLATORS

- **INFLATION RANGE:** 0-174 PSI • **ACCURATE TO:** ± 1.2 psi
- Auto ON, upon air pressure sensing • Large tilted LCD display with backlight and 90 second auto OFF • Multi-scale gauge • Die-cast aluminum unit with rubber protective sleeve • Lightweight handle and trigger • Wire sheathed hose on flex area of hose to eliminate kinking



Ascot No.	Mfg. No.	Description
477-11235	11.0723ASC5	RPG Digital Inflator: 20" Hose w/ Clip-On Chuck
477-11237	11.0723ASC7	RPG Digital Inflator: 6' Hose w/ Clip-On Chuck
477-11239	—	Replacement 6' Hose w/ Clip-On Chuck for Digital Inflators
477-11240	—	Replacement 20" Hose w/ Clip-On Chuck for Digital Inflators

INFLATOR GAUGES



PRO DIGITAL TIRE INFLATOR

- **ACCURATE:** Measures in PSI (0-255), kPa (0-1800), kg/cm² (0-18), and Bar (0-18). Meets ANSI/ASME B40.1 standards
- **GAUGE SWIVELS:** Reads at any angle, lays flat in your toolbox. Gauge protected by rubber boot
- **BACKLIT DISPLAY:** Auto-on when tire pressure is detected; Auto-off after inactivity to save battery
- **EASY HANDLING:** Durable/ergonomic grip. Quick fine tuning in case you exceed the target pressure
- **6" STRAIGHT FOOT CHUCK:** Full swivel and hose w/threaded lock-on design, enabling hands-free inflation

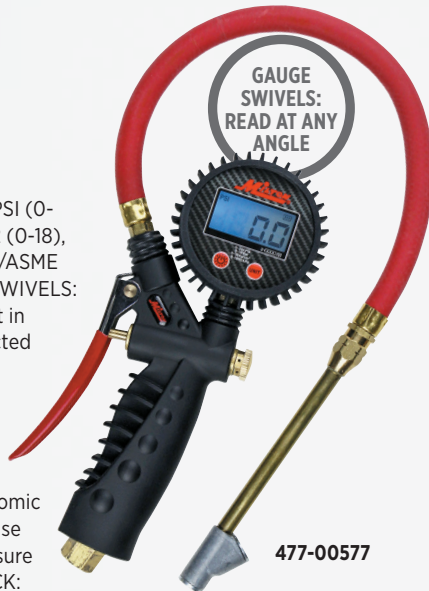

477-00577

Ascot No.	Mfg. No.	Description
477-00577	S-577D	Pro Digital Tire Inflator - 15" Hose w/ Lock-On Threads



DIGITAL HAND-HELD TIRE INFLATOR*

- **INFLATION RANGE:** 0 - 174 PSI
- **ACCURACY:** +/- .2 PSI
- **6' Hose** • Lightweight shock-resistant design
- High specification ceramic sensor • Long life, easily replaceable battery
- Available in custom hose lengths and chuck styles
- Valve has provisions for checking air pressure during inflation
- Threaded for 1/4" male NPT hose fittings



477-10001

Ascot No.	Mfg. No.	Description
477-10001	Accura 1	Digital Hand-Held Tire Inflator

* This gauge provides more accurate air pressure readings which is essential with TPMS.



DILL DIGITAL INFLATORS W/ STAINLESS STEEL HOSE

- **Two-foot, kink-resistant, stainless steel hose**
- Large backlit display
- Auto on/off feature
- Dual foot or Clip-on
- Made in the USA air chuck
- **Assembled and tested in the USA**

477-76263



Ascot No.	Mfg. No.	Description
477-72623	7260-S2-6293E	Digital Inflator - 2 Ft. Stainless Steel Hose - USA-Made Clip-On Chuck
477-72629	7260-S2-6999FT	Digital Inflator - 2 Ft. Stainless Steel Hose - USA-Made Dual Foot Chuck

MK4 HEAVY DUTY HAND-HELD INFLATOR

- **NEW VIEWING WINDOW:** Larger window gives 20% greater field of viewing
- **LIGHTER WEIGHT:** Gauge body weighs 2.035lbs, less work strain and easier for repetitive use
- **BIOMORPHIC SHAPE:** Ergonomic, easier to use and less prone to damage when dropped
- **NEW VALVE MECHANISM:** Simplified 2-stage mechanism design prevents user having to "push" against full line pressure on deflate preventing fatigue
- **NEW PISTON & SEAL DESIGN:** New design, less drag, reduced friction & less movement inertia means no internal corrosion, no sticking and no skewing of accuracy
- **NEW CLEAR LITHOGRAPHIC DESIGN:** Fast and accurate reading of results
- **MAXIMUM INFLATION PRESSURE:** 160 PSI



477-10004

Ascot No.	Mfg. No.	Description
477-10004	MK4	MK4 Heavy Duty Hand-Held Inflator



WARNING: Never inflate a tire on a multi-piece rim (a rim made up of 2 or more separate pieces) unless the tire and rim are mounted in OSHA regulation 29-CFR Part 1910.177 or D.O.T. approved tire inflation cage. OSHA Regulations require that an inflator gauge must be equipped with a lock-on chuck and have a hose extension sufficiently long for the operator to stand clear of the possible trajectory of a multi-piece rim.



WARNING: For more information go to www.P65Warnings.ca.gov.



DILL DIGITAL TIRE INFLATOR GAUGE

- Digital backlight readout • 0-170 PSI range • 2 or 6ft. hose • Clip-on or dual-foot chuck
- ASSEMBLED AND TESTED IN THE USA



477-76063

Ascot No.	Mfg. No.	Description
477-76023	7260-2-6293E	Digital Inflator - 2 Ft. Hose - Clip-On Chuck
477-76029	7260-2-6999FT	Digital Inflator - 2 Ft. Hose - Straight Chuck
477-76063	7260-6-6293E	Digital Inflator - 6 Ft. Hose - Clip-On Chuck
477-76069	7260-6-6999FT	Digital Inflator - 6 Ft. Hose - Straight Chuck



HEAVY DUTY HOSE INFLATOR

- Has two separate clip-on chucks with five-foot hoses • One chuck, CH-360, fits standard bore valves and the other, H-4660A, large bore valves • Has springloaded, hand-operated valve and has provisions for checking air pressure during inflation
- Threaded for 1/4" male NPT hose fittings



477-00404

Ascot No.	Mfg. No.	Description
477-00404	I-404	Heavy Duty Hose Inflator

DILL DIGITAL INFLATORS W/ STAINLESS STEEL HOSE

- Two-foot, kink-resistant, stainless steel hose • Large backlit display
- Auto on/off feature • Dual foot or Clip-on Made in the USA air chuck
- Assembled and tested in the USA



477-76263



Ascot No.	Mfg. No.	Description
477-76263	7260-S2-6293E	Digital Inflator - 2 Ft. Stainless Steel Hose - USA-Made Clip-On Chuck
477-76269	7260-S2-6999FT	Digital Inflator - 2 Ft. Stainless Steel Hose - USA-Made Dual Foot Chuck

PRECISION DIGITAL TIRE INFLATOR

- Most accurate pressure gauge on the market (0-160 PSI), Extreme ± 0.05% Accuracy
- EASY-TO-READ DIGITAL DISPLAY: Large articulating easy to read digital display that is easy to read in any light condition, at any angle, display automatically adjusts for left or right handed use, or vertical portrait mode • High contrast electrophonic screen • AUTO



477-00587

ON/OFF FEATURE: Powers on when air pressure is detected, power off after 120 seconds of inactivity

- Deflation button • Job site work light, valve cap holder, integrated hand socket for storage

477-00587	S-580e-KIT	Precision Digital Tire Inflator - Dual Foot Chuck
-----------	------------	---



INFLATOR GAUGES



AIR LINE INFLATORS

- Ideal for gauging and inflating dual tires on trucks and buses as well as passenger cars and light trucks
- Solid brass indicator bar
- Allows operator to stand away while inflating and deflating tires
- Bleeder valve allows user to adjust tire pressure without touching either the tire or valve stem



Standard #	Hand Held #	Digital Body #	Description
AIR LINE INFLATOR GAUGE			
477-00001	477-20001	477-30001	12" Hose w/ Dual Foot Chuck
477-00011	N/A	477-30011	12" Hose w/ Tapered Chuck
477-00111	477-20111	477-30111	12" Hose w/ Lock-On Chuck
477-01111	477-21111	477-31111	12" Hose w/ No Chuck
477-11111	N/A	N/A	12" Hose w/ Lock-On Chuck & Bleeder Valve
SAFETY INFLATOR GAUGE			
477-00002	477-20002	477-30002	3' Hose w/ Ball Foot (Clip-On) Chuck
477-00003	477-20003	477-30003	3' Hose w/ Straight Lock-On Chuck
477-00004	477-20004	477-30004	6' Hose w/ Ball Foot (Clip-On) Chuck
477-00005	477-20005	477-30005	6' Hose w/ Straight Lock-On Chuck
477-00008	477-20008	477-30008	9' Hose w/ Ball Foot (Clip-On) Chuck
477-00009	477-20009	477-30009	9' Hose w/ Straight Lock-On Chuck
477-00010	477-20010	477-30010	12' Hose w/ Ball Foot (Clip-On) Chuck
477-00012	477-20012	477-30012	12' Hose w/ Straight Lock-On Chuck
477-00014	477-20014	477-30014	6' Hose w/ No Chuck
477-00015	477-20015	477-30015	15' Hose w/ Straight Lock-On Chuck
477-00020	477-20020	477-30020	20' Hose w/ Straight Lock-On Chuck
477-00033	477-20033	477-30033	3' Hose w/ Euro-Style Chuck
477-00066	477-20066	477-30066	6' Hose w/ Euro-Style Chuck
477-00099	477-20099	477-30099	9' Hose w/ Euro-Style Chuck
477-00112	477-20112	477-30112	3' Hose w/ No Chuck
477-00113	477-20113	477-30113	3' Hose w/ Sleeve Chuck
477-00115	477-20115	477-30115	6' Hose w/ Black Epoxy Lock-On Chuck
477-00118	477-20118	477-30118	9' Hose w/ No Chuck
477-00144	477-20144	477-30144	12' Hose w/ Euro-Style Chuck
477-01112	477-21112	477-31112	12' Hose w/ No Chuck

LARGE BORE AIR LINE INFLATOR GAUGES

- Large Bore inflation unit with in-line gauge • Equipped with AC-B12 large bore chuck • Gauge is calibrated 10-140 PSI in 2 lb. increments • Available in hose lengths of 6', 9' & 12' • 477-01006 Similar to Haltec I-409



Ascot No.	Description
477-01006	6' Hose with AC-B12 Large Bore Chuck
477-01009	9' Hose with AC-B12 Large Bore Chuck
477-01012	12' Hose with AC-B12 Large Bore Chuck
477-00409	6' Hose with Large Bore Inflation Gauge

HEAVY DUTY TIRE CHANGERS



CEMB^{USA}

CM27T HEAVY DUTY TRUCK TIRE CHANGER

- For tube and tubeless type tires used on over-the-road Class 8 commercial trucks and some off-road tractor tires and rims
- The pivoting four-jaw clamping chuck aids as a wheel lift and prevents liabilities of manual truck tire changing by allowing the machine to perform all the heavy lifting and service work
- Mobile cable control unit
- Bi-directional rotation
- Self centering universal wheel chuck
- Rim pliers and rim lever standard

MOBILE CABLE CONTROL UNIT

RIM PLIERS AND RIM LEVER



446-00027

SM56T HEAVY DUTY TIRE CHANGER

- For tube and tubeless tires used on heavier off-road farm and commercial use tractors
- Mobile cable control unit
- Two speed hydraulic pump motor
- Bi-directional rotation
- Self centering universal wheel chuck
- Self-centering four jaw clamping jaw drive system which doubles as a wheel lift
- Rim pliers and rim lever standard



446-00056

2-SPEED HYDRAULIC PUMP MOTOR

MOBILE CABLE CONTROL UNIT

RIM PLIERS AND RIM LEVER

CEMB HEAVY DUTY TIRE CHANGER SPECIFICATIONS

Ascot No.	Mfg. No.	Power Supply	Rim Clamping Range	Max Tire Outside	Max Tire Width	Max Tire Weight	Bead Breaker Force	Shipping Weight
446-00027	CM27T	220 VAC	13" - 27"	63"	30"	3300 lbs.	4100 lbs.	1415 lbs.
446-00056	SM56T	220 VAC	14" - 46"	90.5"	42"	3300 lbs.	6000 lbs.	2000 lbs.



HEAVY DUTY TIRE CHANGERS



HD700 HEAVY DUTY TIRE CHANGER

- For demounting and mounting inner tube and tubeless type tires for trucks, buses and industrial vehicles with annular groove or elastic ring type rims
- Can be used to work easily on any rim size up to 26"

HD1300 HEAVY DUTY TIRE CHANGER

- Extremely compact dimensions for working with complete peace of mind on truck, agricultural machine and earth moving machine wheels • Features a sturdy and robust operated tool arm

HD1300R HEAVY DUTY TIRE CHANGER (WIRELESS)

- Extremely compact dimensions for working with complete peace of mind on truck, agricultural machine and earth moving machine wheels • Features a sturdy and robust operated tool arm

FOR INNER TUBE & TUBELESS TYPE TIRES

ANY RIM SIZE UP TO 26"

COMPACT IN SIZE

WIRELESS

COMPACT IN SIZE



443-03504



443-01804



443-03514

CORGI TIRE CHANGER SPECIFICATIONS

Ascot No.	Mfg. No.	Power Supply	Max Tire Outside	Max Rim Width	Gross Shipping Weight
443-01804	HD700	208 vac +/-10%,3 ph., 30 amp circuit	63"	26"	1500 lb.
443-03504	HD1300	208 vac +/-10%,3 ph., 30 amp circuit	86"	56"	2450 lb.
443-03514	HD1300R	208 vac +/-10%,3 ph., 30 amp circuit	86"	56"	2450 lb.



HD1400 HEAVY DUTY TIRE CHANGER

- **Semi-automatic tire changer**
- Capable of handling tire widths of up to 58" and a maximum wheel weight of 4189 lb.
- Electric-hydraulic operation
- Features the START & STOP function, guaranteeing notable energy savings while the machine is not being used

MONSTERAGTT HEAVY DUTY TIRE CHANGER

- **Significant reduction in strain**
- High protection of rims and tires
- High performance
- Maximum safety
- Reliable universal application

HD1800 HEAVY DUTY TIRE CHANGER

- **Works on mining, forestry and agricultural wheels and tires up to 118" and 6,600 lb.**
- Cordless remote control
- Automatic tool head



443-01504

START & STOP FUNCTION

ELECTRIC-HYDRAULIC OPERATION

HEAVY DUTY

MAXIMUM SAFETY

RIM & TIRE PROTECTION

RIM & TIRE PROTECTION

HEAVY DUTY

CORDLESS REMOTE



443-00409



443-04002

CORCHI TIRE CHANGER SPECIFICATIONS

Ascot No.	Mfg. No.	Power Supply	Max Tire Outside	Max Rim Width	Gross Shipping Weight
443-00409	HD1400	208 vac +/-10%, 3 ph., 30 amp circuit	98.5"	58"	2960 lb.
443-04002	HD1800	208 vac +/-10%, 3 ph., 30 amp circuit	118"	50"	5350 lb.
443-01504	MonsterAGTT	208 vac +/-10%, 3 ph., 30 amp circuit	98"	58"	3500 lb.

WHEEL BALANCERS



CEMB^{USA}

C212 MOTORIZED DIGITAL TRUCK WHEEL BALANCER WITH PNEUMATIC LIFT

- C212 balances steel & light alloy wheels of cars, light & heavy commercial trucks and bus thanks to a 40mm shaft and a large assortment of adaptors and cones standard
- Pneumatic stationary brake useful during wheel mounting and counterweight application
- Pedal operated pneumatic lift (soft type) enables excellent centering accuracy of the wheel on the shaft
- Automatic Distance & Diameter Entry (2D)
- Fully Automatic Cycle with Breaking
- 51" wheel guard
- Self-Diagnosis and Self-Calibration
- **MENUS FOR QUICK SELECTION OF THE FOLLOWING:** Inches to millimeters, unbalanced thresholds 0.1 or 0.25 ounces (1 or 5g)
- Direct selection ounces/grams
- Optimization program for compensation of rim and tire unbalance
- "Static" program—plus 4 ALU programs for PAX, light alloy or special shaped rims
- One Button Split & Hidden Weight Program
- Direct weight location program (no repositioning of stick-on weights)

PNEUMATIC
STATIONARY
BRAKE

FULLY
AUTOMATIC
CYCLE

481-00212



Ascot No.	Mfg. No.	Description
481-00212	C212	Motorized Digital Truck Wheel Balancer with Pneumatic Lift

C206 MOBILE HAND SPIN TRUCK WHEEL BALANCER

- **Mobile Hand Spin Truck Wheel Balancer for cars and light & commercial trucks**
- C206 balances HD truck and bus tires as well as light truck and car tires
- Portable for mobile service when 12VDC available
- Automatic Distance & Diameter Entry (2D)
- Standard lightweight battery pack for use when power not available
- Self-Diagnosis and Self-Calibration
- **MENUS FOR QUICK SELECTION OF THE FOLLOWING:** Inches to millimeters, unbalanced thresholds 0.1 or 0.25 ounces (1 or 5g)
- Direct selection ounces/grams
- Optimization program for compensation of rim and tire unbalance
- "Static" program—plus 4 ALU programs for PAX, light alloy or special shaped rims
- One Button Split & Hidden Weight Program
- Direct weight location program (no repositioning of stick-on weights)

PORTABLE
FOR MOBILE
SERVICE

481-00206



Ascot No.	Mfg. No.	Description
481-00206	C206	Mobile Hand Spin Truck Wheel Balancer

CORGHI

ET66 MOTOR DRIVEN BALANCER

- **Precise motor-driven balancer designed for heavy duty wheels and can also accommodate passenger wheels**
- Compact, easy to use and reliable
- LED display provides ease of use, manual data entry and comes with dynamic, static, and alum programs
- Low balancing speed reduces spin times
- User-friendly keyboard

HEAVY
DUTY

COMPACT
& EASY
TO USE

443-90201



Ascot No.	Mfg. No.	Power Supply	Max Tire Outside	Gross Shipping Weight
443-90201	ET66	110V/1ph/60hz	52"	485 lb.

PORTA TRUER

- Fast Accurate and dependable
- Designed to roll up to any vehicle and true the tire without removing the wheel

Ascot No.	Mfg. No.	Description
456-00405	405W	Porta Truer



CLHM-140 AND CLHM-190: HEAVY DUTY MOBILE COLUMN LIFTS

- Challenger’s heavy-duty mobile lifting system are robust, yet easily maneuverable and can be operated on almost any solid surface, indoors or out
- Our heavy-duty mobile lifts are also capable of lifting vehicles of any axle length or wheelbase
- Mobile lifts provide the flexibility and convenience to lift any rubber-tired vehicle, from small passenger cars to large 2-, 3- or 4-axle vehicles up to 152,000 pounds
- Models are available in 14,000 lb. or 19,000 lb. capacity columns



The CHLM locks.



The CHLM lifting system is conveniently wireless for a clutter-free work area.



Ascot No.	Mfg. No.	Description
308-00140	CHLM 140-4	14,000 lb. Capacity Mobile Column Lift
308-00190	CHLM 190-4	19,000 lb. Capacity Mobile Column Lift

TRUCK WHEEL WEIGHTS



“LT1” SERIES - WHEEL WEIGHTS

• For light trucks, 3/4 & 1 ton vehicles with either tube or tubeless rims where such rims are too thick for “P” series weights • For use on heavier trucks with thin rim flanges • Use “P” series weights on 1/2 ton vehicles • Use rim gauge RG2 to verify correct application

NOTE: LT1 = BTS

Ascot No.	Mfg. No.	Weight
“LT1” SERIES		
489-05005	LT1 50	0.5 Oz.
489-05010	LT1 100	1.0 Oz.
489-05015	LT1 150	1.5 Oz.
489-05020	LT1 200	2.0 Oz.
489-05025	LT1 250	2.5 Oz.
489-05030	LT1 300	3.0 Oz.
489-05035	LT1 350	3.5 Oz.
489-05040	LT1 400	4.0 Oz.
489-05045	LT1 450	4.5 Oz.
489-05050	LT1 500	5.0 Oz.
489-05060	LT1 600	6.0 Oz.

QUANTITY: 25 per box



489-05020

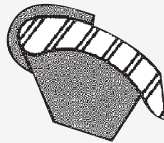

“RC” SERIES - WHEEL WEIGHTS

• Used on heavy duty trucks with Firestone or Accuride, Radial Commander rims • Can be used with new strip steel rims with curved edges • Use rim gauge RG2 to verify correct application

NOTE: RC = BTRC

Ascot No.	Mfg. No.	Weight
“RC” SERIES		
489-09020	RC 020	2.0 Oz.
489-09030	RC 030	3.0 Oz.
489-09040	RC 040	4.0 Oz.
489-09060	RC 060	6.0 Oz.
489-09080	RC 080	8.0 Oz.
489-09100	RC 100	10.0 Oz.
489-09120	RC 120	12.0 Oz.

QUANTITY: 25 pieces per box except 10 and 12 Oz. are 20 per box



489-09040



“CT” SERIES - WHEEL WEIGHTS

• Used on heavy duty trucks with Firestone or Accuride, Budd or Goodyear tubeless rims (except steel rims with curved edges) • Primarily used on rim widths of 6.75", 7.50" and 8.25"

NOTE: CT = BTLT



489-02060

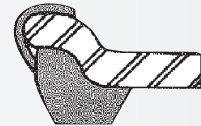

Ascot No.	Mfg. No.	Weight
“CT” SERIES		
489-02020	CT 200	2.0 Oz.
489-02030	CT 300	3.0 Oz.
489-02040	CT 400	4.0 Oz.
489-02060	CT 600	6.0 Oz.
489-02080	CT 800	8.0 Oz.
489-02100	CT 1000	10.0 Oz.
489-02120	CT 1200	12.0 Oz.
489-02140	CT 1400	14.0 Oz.
489-02160	CT 1600	16.0 Oz.

QUANTITY: 25 per box

“TS” SERIES - WHEEL WEIGHTS FOR LIGHT TRUCK ALLOY WHEELS

• All 1997 and newer Ford trucks with alloy and steel wheels use the “TS” series wheel weight • For use on many domestic trucks with decorative steel wheels, Ford truck new alloy wheels • Weights fit new domestic full size trucks equipped with wheels using thicker flanges and chrome or powder coatings • Weights larger and use different clip configurations

NOTE: TS = TN = TTC



489-08100

APPLICATIONS - TS SERIES

CHEVROLET: Full Size Pick Up, Suburban, Yukon, Tahoe from 2000; **FORD:** Expedition from 1997, F-100, F-150 from 1997; **LINCOLN:** Lincoln Navigator with alloy & steel wheels from 1998

Ascot No.	Mfg. No.	Weight
“TS” SERIES		
489-08025	TS 25	0.25 Oz.
489-08050	TS 50	0.50 Oz.
489-08075	TS 75	0.75 Oz.
489-08100	TS 100	1.00 Oz.
489-08125	TS 125	1.25 Oz.
489-08150	TS 150	1.50 Oz.
489-08175	TS 175	1.75 Oz.
489-08200	TS 200	2.0 Oz.
489-08225	TS 225	2.25 Oz.
489-08250	TS 250	2.50 Oz.
489-08275	TS 275	2.75 Oz.
489-08300	TS 300	3.0 Oz.
489-08325	TS 325	3.25 Oz.
489-08350	TS 350	3.50 Oz.
489-08375	TS 375	3.75 Oz.
489-08400	TS 400	4.0 Oz.
489-08425	TS 425	4.25 Oz.
489-08450	TS 450	4.50 Oz.
489-08475	TS 475	4.75 Oz.
489-08500	TS 500	5.0 Oz.

QUANTITY: 25 per box

“I7” SERIES - WHEEL WEIGHTS

• **Most popular weight for the medium duty truck** • Used on most trucks with tube type tires

NOTE: I7 = BTLM + E

Ascot No.	Mfg. No.	Weight
“I7” SERIES		
489-55010	I7100	1.0 Oz.
489-55020	I7200	2.0 Oz.
489-55030	I7300	3.0 Oz.
489-55040	I7400	4.0 Oz.
489-55050	I7500	5.0 Oz.
489-55060	I7600	6.0 Oz.
489-55080	I7800	8.0 Oz.
489-55100	I71000	10.0 Oz.
489-55120	I71200	12.0 Oz.
489-55140	I71400	14.0 Oz.
489-55160	I71600	16.0 Oz.

QUANTITY: 25 pieces per box except 10 & 12 Oz.; 20/box & 14 & 16 Oz.; 10/box



489-55040



CTZ TYPE

• **Used on heavy duty trucks with Firestone or Accuride, Budd or Goodyear tubeless rims (except steel rims with curved edges)** • Primarily used on rim widths of 6.75”, 7.50” and 8.25”

NOTE: CT = BTLT



Ascot No.	Plombco CTZ Series No.	Weight
CT: ZINC		
489-24200	CTZ-2.00	2.0 Oz.
489-24300	CTZ-3.00	3.0 Oz.
489-24400	CTZ-4.00	4.0 Oz.
489-24500	CTZ-5.00	5.0 Oz.
489-24600	CTZ-6.00	6.0 Oz.

QUANTITY: 25 per box



Plombco

“TAL” SERIES - WHEEL PROTECTORS® WEIGHTS

• **Special weight for all Alcoa and Accuride (from 1983) aluminum tubeless heavy truck wheels; fits both sides of the wheel** • Replace the “OS-TAL” and “DS-TAL” series • Use rim gauge RG2 to verify correct application (either OS-TAL or DS-TAL slot) • Recommend coated weights on all vehicles having alloy wheels

NOTE: TAL = BTCAL

Ascot No.	Mfg. No.	Weight
“TAL” SERIES		
489-10020	TALS-2.00	2.0 Oz.
489-10030	TALS-3.00	3.0 Oz.
489-10040	TALS-4.00	4.0 Oz.
489-10060	TALS-6.00	6.0 Oz.
489-10080	TALS-8.00	8.0 Oz.

QUANTITY: 25 per box



489-10030

I7Z TYPE

• **Most popular weight for the medium duty truck** • Used on most trucks with tube type tires

NOTE: I7 = BTLM + E



Ascot No.	Plombco I-7Z Series No.	HPW I7Z Series No.	Wgt.
I7: ZINC			
489-22100	I7Z-1.00	I7Z-010	1.0 Oz.
489-22150	-	I7Z-015	1.5 Oz.
489-22200	I7Z-2.00	I7Z-020	2.0 Oz.
489-22250	-	I7Z-025	2.5 Oz.
489-22300	I7Z-3.00	I7Z-030	3.0 Oz.
489-22350	-	I7Z-035	3.5 Oz.
489-22400	I7Z-4.00	I7Z-040	4.0 Oz.
489-22500	I7Z-5.00	I7Z-050	5.0 Oz.
489-22600	I7Z-6.00	-	6.0 Oz.
489-22800	I7Z-8.00	-	8.0 Oz.

QUANTITY: 25 per box except 10 & 12 Oz.; 20/box & 14 & 16 Oz.; 10/box



Plombco



HPW

TRUCK WHEEL WEIGHTS



LT1Z TYPE

• For light trucks, 3/4 & 1 ton vehicles with either tube or tubeless rims where such rims are too thick for “P” series weights • For use on heavier trucks with thin rim flanges • Use “P” series weights on 1/2 ton vehicles • Use rim gauge RG2 to verify correct application

NOTE: LT1 = BTS

Ascot No.	Plombco LT1Z Series No.	HPW LT1Z Series No.	Wgt.
LT1: ZINC			
489-21050	LT1Z-0.50	LT1Z-005	.5 Oz.
489-21100	LT1Z-1.00	LT1Z-010	1.0 Oz.
489-21150	LT1Z-1.50	LT1Z-015	1.5 Oz.
489-21200	LT1Z-2.00	LT1Z-020	2.0 Oz.
489-21250	LT1Z-2.50	LT1Z-025	2.5 Oz.
489-21300	LT1Z-3.00	LT1Z-030	3.0 Oz.
489-21350	LT1Z-3.50	LT1Z-035	3.5 Oz.
489-21400	LT1Z-4.00	LT1Z-040	4.0 Oz.
489-21450	-	LT1Z-045	4.5 Oz.
489-21500	-	LT1Z-050	5.0 Oz.

QUANTITY: 25 per box

TALZ TYPE

• Special weight for all Alcoa and Accuride (from 1983) aluminum tubeless heavy truck wheels; fits both sides of the wheel • Replace the “OS-TAL” and “DS-TAL” series • Use rim gauge RG2 to verify correct application (either OS-TAL or DS-TAL slot) • Recommend coated weights on all vehicles having alloy wheels

NOTE: TALS = TAL = BTCAL

Ascot No.	Plombco TALZ-S Series No.	HPW TALZ Series No.	Wgt.
TAL: ZINC			
489-23100	-	TALZ-010	1.0 Oz.
489-23200	TALZS-2.00	TALZ-020	2.0 Oz.
489-23300	TALZS-3.00	TALZ-030	3.0 Oz.
489-23400	TALZS-4.00	TALZ-040	4.0 Oz.
489-23500	TALZS-5.00	TALZ-050	5.0 Oz.
489-23600	TALZS-6.00	TALZ-060	6.0 Oz.

QUANTITY: 25 per box



Plombco



HPW



Plombco



HPW

RCZ TYPE

• Used on heavy duty trucks with Firestone or Accuride, Radial Commander rims • Can be used with new strip steel rims with curved edges • Use rim gauge RG2 to verify correct application

Ascot No.	Plombco RCZ Series No.	Weight
RC: ZINC		
489-64804	RCZ-2.00	2.00 Oz.
489-64806	RCZ-3.00	3.00 Oz.
489-64808	RCZ-4.00	4.00 Oz.
489-64810	RCZ-5.00	5.00 Oz.
489-64812	RCZ-6.00	6.00 Oz.

QUANTITY: 25 per box



Plombco



Truck wheel weights in use.

ADHESIVE WHEEL WEIGHTS



PLOMBCO LEAD ADHESIVE: RUBBER TAPE



312 - Rubber Tape



314 - Rubber Tape



412 - Rubber Tape



612 - Rubber Tape

Ascot No.	MFG. No.	Tape Type	Description
PLOMBCO LEAD ADHESIVE: RUBBER TAPE			
484-31230	312-30	Rubber Tape	30 - 6" Bars - 1/4 Oz. Segments - 3/4" Wide
484-31252	312-52	Rubber Tape	52 - 6" Bars - 1/4 Oz. Segments - 3/4" Wide
484-31430	314-30	Rubber Tape	30 - 6" Bars - 1/4 Oz. Segments - 1/2" Wide
484-41215	412-15	Rubber Tape	15 - 6" Bars - 1/2 Oz. Segments - 3/4" Wide
484-41230	412-30	Rubber Tape	30 - 6" Bars - 1/2 Oz. Segments - 3/4" Wide
484-51215	512-15	Rubber Tape	15 - 6" Bars - 1 Oz. Segments - 3/4" Wide
484-61215	612-15	Rubber Tape	15 - 6" Bars - 2 Oz. Segments - 1-1/4" Wide

PLOMBCO LEAD ADHESIVE: COLD WEATHER TAPE

• Save time and money by eliminating the need to heat the wheel when temperatures are below 40 degrees Fahrenheit



312 - Rubber Tape, Cold Weather Tape



314 - Rubber Tape, Cold Weather Tape



412 - Rubber Tape, Cold Weather Tape



612 - Rubber Tape, Cold Weather Tape

Ascot No.	MFG. No.	Tape Type	Description
PLOMBCO LEAD ADHESIVE: COLD WEATHER TAPE			
484-31231	312-30BCW	Cold Weather	30 - 6" Bars - 1/4 Oz. Segments - 3/4" Wide, Black
484-31233	312-30CW	Cold Weather	30 - 6" Bars - 1/4 Oz. Segments - 3/4" Wide
484-31432	314-30CW	Cold Weather	30 - 6" Bars - 1/4 Oz. Segments - 1/2" Wide
484-33252	312-52CW	Cold Weather	52 - 6" Bars - 1/4 Oz. Segments - 3/4" Wide
484-41232	412-30CW	Cold Weather	30 - 6" Bars - 1/2 Oz. Segments - 3/4" Wide
484-53215	512-15CW	Cold Weather	15 - 6" Bars - 1 Oz. Segments - 3/4" Wide
484-63215	612-15CW	Cold Weather	15 - 6" Bars - 2 Oz. Segments - 1-1/4" Wide

PERFECT QUIKSTIK™ SEGMENTED ADHESIVE STYLE LEAD WHEEL WEIGHTS

• Only pre-cut pre-taped weight • No cutting, no pre-contouring and no waste • Each segment is stamped with the actual weight in ounces and grams • Available in 1/2", 3/4" low profile and 3/4" truck weight design • Wheel weight for racing/off road performance applications



484-11360



484-13360



484-00006



484-30360



484-00112

Ascot No.	MFG. No.	Weight	Description
PERFECT LEAD ADHESIVE			
484-11360	100360	3 Oz.	Pre-Taped Weight 30 Strips of .25 Oz. Segments
484-10720	100720	3 Oz.	Pre-Taped Weight 60 Strips of .25 Oz. Segments
484-00012	200624S	3 Oz.	Pre-Taped Weight 48 Strips of .25 Oz. Segments
484-13360	200624	3 Oz.	Pre-Taped Weight 52 Strips of .25 Oz. Segments
484-30360	300360	6 Oz.	Pre-Taped Truck Weight 30 Strips of 1 Oz. Segments
484-00006	CL6	6 Oz.	Pre-Taped Truck Weight 30 Strips of 1 Oz. Segments
484-00112	CL12	12 Oz.	Pre-Taped Truck Weight 8 Strips of 2 Oz. Segments



ADHESIVE WHEEL WEIGHTS



STEEL SEGMENTED ADHESIVE-STYLE WHEEL WEIGHTS

ALL STEEL

• **Pre-cut weights** • No cutting, no pre-contouring and no waste • Each segment is stamped with the actual weight in ounces • US white “quick” tape



484-16001



484-17026



484-17127



484-27026



484-37026

PERFECT QUIKSTIK™ SEGMENTED ADHESIVE-STYLE STEEL WHEEL WEIGHTS

• **Only pre-cut, pre-taped weight** • No cutting, no pre-contouring and no waste • Each segment is stamped with the actual weight in ounces and grams



484-00300



484-20576



484-30336

Ascot No.	MFG. No.	Description
STEEL SEGMENTED ADHESIVE-STYLE WHEEL WEIGHTS		
484-16001	1184	1 Oz. Steel Adhesive Wheel Weights: 1 Oz. Strips, 4 Segments (18 Strips per Box)
484-17026	14308	1/4 Oz. Steel Adhesive Wheel Weights with Plastic Powder Coating: 1/4 Oz. Strips, 8 Segments (30 Strips per Box)
484-17127	12187	1/2 Oz. Steel Adhesive Wheel Weights: 1/2 Oz. Strips, 7 Segments (18 Strips per Box)
484-27026	14308W	1/4 Oz. White Steel Adhesive Wheel Weights with White Powder Coating: 1/4 Oz. Strips, 8 Segments (30 Strips per Box)
484-37026	14308B	1/4 Oz. Black Steel Adhesive Wheel Weights with Black Powder Coating: 1/4 Oz. Strips, 8 Segments (30 Strips per Box)

Ascot No.	MFG. No.	Description
PERFECT QUIK-STIK SEGMENTED ADHESIVE-STYLE STEEL WHEEL WEIGHTS		
484-00300	SST300N	Pre-Taped Steel Weight - 3 Oz. Segments
484-00060	SSG060N	Pre-Taped Steel Weight - 60 Gram Segments
484-20624	200624ST	Pre-Taped Steel Weight - 3 Oz. Segments
484-20576	200576FE	Pre-Taped Steel Weight - 3 Oz. Segments (No QuikTAB™ feature.)
484-22576	200576FEBLK	Pre-Taped Black Steel Weight - 3 Oz. Segments (No QuikTab Feature)
484-30336	300336FE	Pre-Taped Steel Weight - 6 Oz. Segments
484-31360	300360ST	Pre-Taped Steel Weight - 6 Oz. Segments

PLOMBCO STEEL ADHESIVE WHEEL WEIGHTS

ALL STEEL

Ascot No.	Mfg. No.	Tape Type	Description
PLOMBCO STEEL ADHESIVE WHEEL WEIGHTS			
484-32230	312Fe-30CW	Cold Weather	30 * 6" Bars Precut in .25 Oz. Segments of .75" Wide
484-32252	312Fe-52CW	Cold Weather	52 * 6" Bars Precut in .25 Oz. Segments of .75" Wide
484-41226	412Fe	OE Adhesive	6", Bars Precut in .5 Oz. Segments of .75" Wide
484-30836	308Fe-36	Rubber Base	2 Oz. strips (1/4 Oz.) (36 Strips per Box)
484-28408	408FE-28	Rubber Base	Steel Adhesive Wheel Weight: 4 Oz. (28 Strips per Box)
484-28418	VL408FES-28	Rubber Base	Value Line Steel Adhesive Wheel Weight: 4 Oz. (28 Strips per Box)
484-28428	VL408FEB-28	Rubber Base	Value Line Black Steel Adhesive Wheel Weight: 4 Oz. (28 Strips per Box)
484-31234	312Fe-30	Rubber Base	Steel Adhesive Wheel Weight: 3 Oz. (30 Strips per Box)
484-31500	VL315FEB	Rubber Base	Value Line Black Steel Adhesive Wheel Weight Roll: 15 lb., 1/4 Oz. Segments
484-31501	VL315FES	Rubber Base	Value Line Steel Adhesive Wheel Weight Roll: 15 lb., 1/4 Oz. Segments
484-35320	320Fe	Rubber Base	Steel Adhesive Wheel Weight Roll: 20 lb., .25 Oz. Segments
484-40848	408Fe-48	Rubber Base	408Fe-48 Steel Adhesive Wheel Weight: 4 Oz. (48 Strips/Box)
484-41500	VL415FEB	Rubber Base	Value Line Black Steel Adhesive Wheel Weight Roll: 15 lb., 1/2 Oz. Segments
484-41501	VL415FES	Rubber Base	Value Line Steel Adhesive Wheel Weight Roll: 15 lb., 1/2 Oz. Segments
484-42010	420Fe	Rubber Base	Steel Adhesive Wheel Weight Roll: 20 lb., .50 Oz. Segments
484-48312	VL312FES-48	Rubber Base	Value Line Steel Adhesive Wheel Weight: 3 Oz. (48 Strips per Box)
484-48322	VL312FEB-48	Rubber Base	Value Line Black Steel Adhesive Wheel Weight: 3 Oz. (48 Strips per Box)
484-50615	506Fe-15	Rubber Base	Steel Adhesive Wheel Weight: 6 Oz. (15 Strips per Box)
484-52001	520Fe	Rubber Base	Steel Adhesive Wheel Weight Roll: 20 lb., 1 Oz. Segments
484-52312	312FE-52	Rubber Base	Steel Adhesive Wheel Weight: 3 Oz. (52 Strips per Box)



Enjoy the benefits and comfort of balancing your wheels by using adhesive wheel weights. The use of these products reduces maintenance costs and prolongs the life of your tires.



484-28408



484-28418



484-28428



484-31234



484-41226



484-48312



484-48322



484-50615

ADHESIVE WHEEL WEIGHTS



BLACK STEEL ADHESIVE WHEEL WEIGHTS



484-10101



484-10201



484-10301

HPW & PERFECT STEEL ADHESIVE WHEEL WEIGHT ROLLS



- Familiar design: Features all of the same standard steel QuikStik characteristics
- Only use the amount of weight you need each time you balance
- Simply pull and rip
- No cutting and no measuring
- MADE IN THE USA



Ascot No.	Mfg. No.	Description
BLACK STEEL ADHESIVE WHEEL WEIGHTS		
484-10101	FSF101B	1/4 Oz. Black Steel Adhesive Wheel Weight: 3 Oz. (48 Strips per Box)
484-10201	FSF102B	1/2 Oz. Black Steel Adhesive Wheel Weight: 3 Oz. (48 Strips per Box)
484-10301	FSF103B	1 Oz. Black Steel Adhesive Wheel Weight: 4 Oz. (36 Strips per Box)
484-67026	24308B	1/2 Oz. Black Steel Adhesive Wheel Weight: 3.5 Oz. Strip (18 Strips per Box)
484-77026	34308B	1 Oz. Black Steel Adhesive Wheel Weight: 4 Oz. Strip (18 Strips per Box)



484-21576



484-32360

Patented QuikTAB™ feature.

Please contact us for further details regarding WHEEL WEIGHTS.

Ascot No.	Mfg. No.	Description
PERFECT STEEL ROLLS		
484-03200	SST32000N	.25 Oz. (1280 Segments)
484-07500	SSG7500N	5G (1500 Segments)
484-21576	200576FER	0.25 Oz. (704 Segments)
484-21624	200624STR	.25 Oz. (1280 Segments)
484-32360	300360STR	.5 Oz. (640 Segments)

STEEL

**PLOMBCO
STEEL ROLLS**

**RUBBER
BASE TAPE**



484-42010



484-51501
Grey Steel Adhesive
Roll: 1/4 oz. Segments

484-61500
Black Steel Adhesive
Roll: 1/2 oz. Segments

Ascot No.	Mfg. No.	Tape Type	Description
PLOMBCO STEEL ROLLS			
484-35320	320Fe	Rubber Base Tape	20 lb. Roll - 1272 Segments (1/4 Oz.)
484-42010	420Fe	Rubber Base Tape	20 lb. Roll - 640 Segments (1/2 Oz.)
484-52001	520Fe	Rubber Base Tape	20 lb. Roll - 320 Segments, (1 Oz.)

ADHESIVE WHEEL WEIGHT ROLLS

STEEL
ZINC

- **Simply use the amount of weight you need each time you balance** • Convenient pull and rip design
- No cutting and no measuring • Rolled weights are more efficient and help reduce waste • Plastic coated • US white "quick" tape



484-47026

Eliminate wasted tape by using rolls!

ADHESIVE WHEEL WEIGHT ROLLS

- Oversized white paper tape
- **Easy to peel**
- Easy to tear by hand
- Available in grey steel or black steel
- 3 rolls per case

Ascot No.	Mfg. No.	Description
484-51500	AVL315FeB	Black Steel Adhesive Roll: 1/4 oz. Segments (960/roll)
484-51501	AVL315FeS	Grey Steel Adhesive Roll: 1/4 oz. Segments (960/roll)
484-61500	AVL414FeB	Black Steel Adhesive Roll: 1/2 oz. Segments (480/roll)
484-61501	AVL415FeS	Grey Steel Adhesive Roll: 1/2 oz. Segments (480/roll)
484-51502	AVL315FeB-CW	Black Steel Adhesive Roll: 1/4 oz. Segments (960/roll) Cold Weather
484-51503	AVL315FeS-CW	Grey Steel Adhesive Roll: 1/4 oz. Segments (960/roll) Cold Weather
484-61502	AVL415FeB-CW	Black Steel Adhesive Roll: 1/2 oz. Segments (480/roll) Cold Weather
484-61503	AVL415FeS-CW	Grey Steel Adhesive Roll: 1/2 oz. Segments (480/roll) Cold Weather

Ascot No.	Mfg. No.	Description
ADHESIVE WHEEL WEIGHT ROLLS		
484-47026	145KG	5 kg Steel Adhesive Wheel Weight Roll: 1/4 Oz. Segments (700 Segments per Roll)
484-57026	245KG	5 kg Zinc Adhesive Wheel Weight Roll: 5G Segments (1000 Segments per Roll)



WHEEL WEIGHT DISPLAYS



METAL WHEEL WEIGHT RACK

- All-metal construction • 8 shelves • Includes dividers • 64 weight locations • Square tube to support the rack



486-31280

ADHESIVE WHEEL WEIGHT ROLL STANDS

- All-metal construction • Accommodates three rolls • Floor mount • Easy to assemble

ALL-METAL DESIGN

EASY TO ASSEMBLE

NEW



486-31282

486-31281

Ascot No.	Mfg. No.	Description
486-31280	MFR	Metal Wheel Weight Rack

Ascot No.	Mfg. No.	Description
486-31281	WWR-3	Adhesive Wheel Weight Roll Stand (3)
486-31282	WWR-4	Adhesive Wheel Weight Roll Stand (4) *For Smaller Rolls

WHEEL WEIGHT TOOLS



PREMIUM HEAVY DUTY PROFESSIONAL WHEEL WEIGHT HAMMER

- Heavy duty construction • Black coated handles with red highlight
- Designed for use on coated wheel weights • Will not mark alloy wheels • Replaceable plastic head available • Made in Taiwan

Ascot No.	Mfg. No.	Description
486-33580	3358	Premium Heavy Duty Wheel Weight Hammer - Red
486-33581	3358-B	Premium Heavy Duty Professional Wheel Weight Hammer - Black
486-33584	335804	Replacement Head

HEAVY DUTY ADHESIVE WHEEL WEIGHT REMOVAL TOOL

- Light weight and easy to use • Easy and quick to remove stick-on wheel weights without damaging rims • The plastic cover of the jaws can protect the alloy rims from damaging or scratching • Adjustable jaws for different types and sizes of wheel weights • Replacement plastic tips available separately

Ascot No.	Mfg. No.	Description
486-00044	P4	Heavy Duty Adhesive Wheel Weight Removal Tool
486-00144	P4R	Replacement Tips for P4 (2-Pack)

PREMIUM FIBERGLASS WHEEL WEIGHT HAMMER

- Used to easily install and remove all types of steel and zinc clip-on wheel weights • Standard with large replaceable hook for prying • Fiberglass shaft for added durability • The hook is made from cold rolled steel • The striking face has a non-marring, surface protective medium-hard replaceable tip • Slip-resistant, ergonomic grip reduces arm strain & fatigue • MADE IN THE USA

Ascot No.	Mfg. No.	Description
486-11000	P110	Premium Fiberglass Wheel Weight Hammer
486-11002	P110-2	Replacement Small Hook for Premium Wheel Weight Hammer
486-11004	P110-4	Replacement Tip for Premium Wheel Weight Hammer
486-11005	8884254	Replacement Large End for P-110 Wheel Weight Hammer

HEAVY DUTY TRUCK WHEEL WEIGHT HAMMER

- Will handle with ease the removal and attachment of HD truck weights
- Fiberglass shaft for a lifetime of use • New chromalloy hooks designed for large wheels and large weights • Larger 1.75" tip for easier application along with heavier total tool weight require less striking effort • Longer handle provides added reach on larger wheels...comfortable, durable rubber handle • Use on all truck wheels
- New industry standard • 12" total length • WEIGHT: 2 lbs. • MADE IN THE USA

Ascot No.	Mfg. No.	Description
486-11011	P110-T	Heavy Duty Truck Wheel Weight Hammer
486-11005	8884254	Replacement Large End for P-110 Wheel Weight Hammer
486-11006	15156	Replacement Tip for Premium Wheel Weight Hammer

COATED WHEEL WEIGHT HAMMER

- Protects valuable wheels from damage • Features replaceable plastic head

Ascot No.	Mfg. No.	Description
486-00233	P-3B	Soft Head Wheel Weight Hammer
486-00133	P-3H	Replacement Head for P-3B Wheel Weight Hammer



WHEEL WEIGHT TOOLS



SPECIALTY WHEEL WEIGHT HAMMERS

Ascot No.	Mfg. No.	Description
486-07129	51400	Truck Wheel Weight Hammer
486-51480	51480	Deluxe Wheel Weight Hammer (Made of heat strengthened steel, comfortable vinyl handle grips, nylon durable hammer replaceable tip)

PASSENGER CAR WHEEL WEIGHT HAMMER

• The industry standard for passenger car wheel weight tools • Not for use on alloy or chrome wheels

Ascot No.	Mfg. No.	Description
486-00011	P-1	Economy Chrome Wheel Weight Hammer

EURO STYLE WHEEL WEIGHT HAMMER

• Heavy Commercial Duty Design • Coated Handles for Comfort • Nickel Plated Vanadium

Ascot No.	Mfg. No.	Description
486-00222	P-2C	Euro-Style Wheel Weight Hammer

HEAVY DUTY ADHESIVE WHEEL WEIGHT REMOVERS

• For use with stick-on wheel weights: Removes emblems, body side moldings and stick-on wheel weights • Scrape off stickers without scratching paint or glass and gaskets from aluminum parts • One piece composite construction can be hit with a hammer • Knobbed handle to prevent hand from slipping while removing wheel weights • Made of high impact plastic • Resharpen with a file when needed • **Equivalent to ESCO 50146**



Ascot No.	Mfg. No.	Description
486-71510	71510	Red Heavy Duty Adhesive Wheel Weight Scraper
486-71511	71511	Black Heavy Duty Adhesive Wheel Weight Scraper



486-51480

486-07129



486-00011

486-00222

RIM GAUGE

• Convenient and economical gauges that guide you to the correct wheel weight application • Helpful with alloy wheels and thinner high strength steel wheels that have numerous new rim configurations



486-75002

Ascot No.	Mfg. No.	Description
486-75002	RG2	Rim Gauge For HD Trucks

Counteract[®]



The only tire and wheel balancing product on the market proven to improve fuel economy in two separate S.A.E. and TMC Type II tests.

Ever wonder what Counteract does inside the tire? Scan the QR code to see Counteract in action.



Featured New Products



5th Wheel Grease

This fifth wheel grease is packaged in convenient, easy-to-apply pouches.

To use, place one pouch on each side of the fifth wheel plate near the base. The pouches rupture when the plate engages the trailer and disintegrates leaving no environmental waste. It is available in a unit of 57-grams.



Six-Way Socket Sets

Available in 1/2", 3/4", and 1" drives

Works in cases of corrosion, rounded lug heads, thin walls for specialty aluminum wheels, etc.

Works on at least 6 different fastener types: Splines, 6-Point, 12-Point, Star, Square, 50% Rounded Off Heads

Impact rated



BALANCING BEADS



COUNTERACT BALANCING BEADS

- **Perfect balance - perfect wear** • Clean, trouble free balancing micro-beads provide continuous self-adjusting balance • No clumping
- Just open the outside package and throw the inside bag into the tire
- Method allows the use of an air blaster to seat the tire on the rim without contaminating the seating area • Air blaster pressure inside the tire will collapse the bag containing Counteract Balancing Beads or the package will break open and release its contents soon after driving • Available in application sizes from half ton vehicles to heavy trucks • All packaging is color coded to tire size on application chart



ECO BALANCE BALANCING BEADS

- **Eco friendly complete wheel assembly internal balancing agent**
- Increase tire life with even tread wear • Lower tire operating temperatures
- TPMS Compatible • Reduce maintenance with easy installation throw-in-bag • Improve fuel economy by reducing rolling resistance • Easy to use application chart • Remain balanced for the life of the tire



Ascot No.	Mfg. No.	Description	Qty./Case
451-00013	CBB-IP-LG	Injector Pump for Counteract Balancing Beads	N/A
451-00203	3 Oz. BP	3 Oz. Bag in Bag of Counteract Balancing Beads	96
451-00204	4 Oz. B	4 Oz. Bag in Bag of Counteract Balancing Beads	92
451-00205	5 Oz. B	5 Oz. Bag in Bag of Counteract Balancing Beads	76
451-00206	6 Oz. B	6 Oz. Bag in Bag of Counteract Balancing Beads	64
451-00208	8 Oz. B	8 Oz. Bag in Bag of Counteract Balancing Beads	52
451-00210	10 Oz. B	10 Oz. Bag in Bag of Counteract Balancing Beads	40
451-00212	12 Oz. B	12 Oz. Bag in Bag of Counteract Balancing Beads	36
451-00214	14 Oz. B	14 Oz. Bag in Bag of Counteract Balancing Beads	32
451-00216	16 Oz. B	16 Oz. Bag in Bag of Counteract Balancing Beads	28

Ascot No.	Mfg. No.	Description	Qty./Case
451-01203	3 Oz. BP-EB	3 Oz. Bag in Bag of Eco Balance Passenger Balancing Beads	96
451-01204	4 Oz. B-EB	4 Oz. Bag in Bag of Eco Balance Beads	92
451-01206	6 Oz. B-EB	6 Oz. Bag in Bag of Eco Balance Beads	64
451-01208	8 Oz. B-EB	8 Oz. Bag in Bag of Eco Balance Beads	52
451-01210	10 Oz. B-EB	10 Oz. Bag in Bag of Eco Balance Beads	40
451-01212	12 Oz. B-EB	12 Oz. Bag in Bag of Eco Balance Beads	36
451-01214	14 Oz. B-EB	14 Oz. Bag in Bag of Eco Balance Beads	32
451-01216	16 Oz. B-EB	16 Oz. Bag in Bag of Eco Balance Beads	28

BALANCING BEADS



MAGNUM+ BALANCING COMPOUND

• **An advanced technology dry tire balancing compound, with superior tire balancing properties** • Formulated from specially-processed multiple-density materials

• Provides continuous and lasting tire balancing for standard, low-profile and wide-base medium truck tires and heavy duty light truck tires • No more time-consuming and expensive mechanical balancing, perfect self-adjusting balance in all your tires, less vehicle wear and tear, easier maintenance and less driver fatigue



451-00200



Ascot No.	Mfg. No.	Sample Tire Size	Qty./Case
451-00150	LTP150	LT215/75/R15	36
451-00200	LTP200	LT235/85R16	24
451-00250	MTP250	33x12.50R15	24
451-00300	MTP300	245/75R22.5	18
451-00400	MTP400	11R22.5/11R24.5	12
451-00500	MTP500	12R24.5	12
451-06000	DPP600	365/80R22.5	6
451-07000	DPP700	425/65R22.5	6

MAGNUM+ FLEET TUBS

• **Each tub is labeled and packaged for a specific premeasured insert bag** • Bulk discounts apply to each tub size • Tubs are durable and reusable with a resealable lid • Complete with a full color label, tubs look great in retail settings and on delivery trucks

• Eliminates wasted extra packaging and tubs are recyclable



MAGNUM+ microbeads distribute themselves evenly inside the tire due to the centrifugal force. A special antistatic coating preserves the mobility of the microbeads for a long time.



451-72305

Ascot No.	Range	Nom. wt.	Description	Qty./Case
451-10003	LFP100 INSERT™	3 Oz.	MAGNUM+ Fleet Tub - Contains 24 LTP100	24
451-15405	LFP150 INSERT™	4-1/2 Oz.	MAGNUM+ Fleet Tub - Contains 24 LTP150	24
451-20605	LFP200 INSERT™	6-1/2 Oz.	MAGNUM+ Fleet Tub - Contains 24 LTP200	24
451-25805	MFP250 INSERT™	8-1/2 Oz.	MAGNUM+ Fleet Tub - Contains 22 MTP250	22
451-31005	MFP300 INSERT™	10-1/2 Oz.	MAGNUM+ Fleet Tub - Contains 18 MTP300	18
451-40013	MFP400 INSERT™	13 Oz.	MAGNUM+ Fleet Tub - Contains 14 MTP400	14
451-60021	DFP600 INSERT™	21 Oz.	MAGNUM+ Fleet Tub - Contains 6 DPP600	6
451-72305	DFP700 INSERT™	23-1/2 Oz.	MAGNUM+ Fleet Tub - Contains 6 DPP700	6



IMI EQUAL FLEXX is an adaptive, internal wheel-end balancing solution that reduces fuel and tire costs by reducing vibration from the wheel end. Developed in partnership with the foremost experts in vibration analysis and testing, its soft, dry particles are engineered to continuously balance tires, creating a smoother ride and more even tire wear for the life of the tire. FLEXX will never damage the tire casing, wheel, or TPMS units. It does not void tire manufacturer warranties.

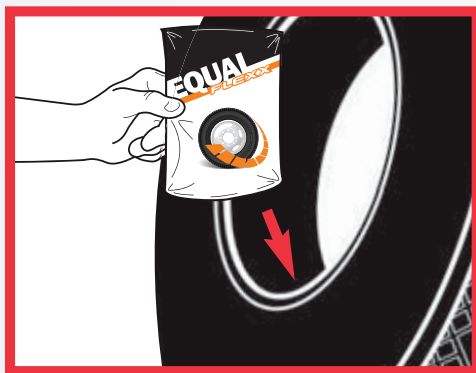

INSTALLATION INSTRUCTIONS

BEFORE INSTALLING FLEXX, READ THE QUANTITY CHART.

1. Simply drop the FLEXX bag into the tire before mounting. Do not tear or open bag.
2. Mount the tire on the wheel, inflate and adjust the air pressure of the tire.
3. Install filtered valve core and identification sleeve.

Avoid over lubricating tire bead or installing FLEXX in tires filled with sealant. Contents are non-toxic, environmentally safe, and non-flammable.



Ascot No.	Mfg. No.	Description
451-32016	EQFXWC32	EQUAL FLEXX Drop In Bag (32) W pkgs. (16 Oz.)
451-40004	EQFXEC40	EQUAL FLEXX Drop In Bag (40) E pkgs. (4 Oz.)
451-40006	EQFXDC40	EQUAL FLEXX Drop In Bag (40) D pkgs. (6 Oz.)
451-40008	EQFXCC40	EQUAL FLEXX Drop In Bag (40) C pkgs. (8 Oz.)
451-40010	EQFXBC40	EQUAL FLEXX Drop In Bag (40) B pkgs. (10 Oz.)
451-40012	EQFXAC40	EQUAL FLEXX Drop In Bag (40) A pkgs. (12 Oz.)
451-40016	EQFXFC40	EQUAL FLEXX Drop In Bag (40) F pkgs. (3 Oz.)



GO BEYOND BALANCE



FUEL COST



TIRE WEAR



PRODUCTIVITY



SMOOTHER RIDE

FLEXX™ is the most scientifically refined internal wheel-end balancer available. It installs in seconds, and keeps fleets running smoothly year after year.

2X MORE VIBRATION ABSORPTION POWER

UP TO 15% BETTER PERFORMANCE

LOWEST ROLLING RESISTANCE, MORE EVEN TIRE WEAR AND THE SMOOTHEST RIDE

EASIEST TO USE



FLEXX
MORE MILES. LESS FUEL



COMMERCIAL TIRE APPLICATION CHART

• Shown below is the Commercial Truck Tire Application Chart. The full Application Quantity Chart, which includes Commercial Light Truck Tires and Light Truck Mudders, can be viewed at www.imiproducts.com/flexx-quantity-chart.

TIRE SIZE	WHEEL POSITION	
	SINGLE	DUAL
TRUCK TIRES		
7.50	R18	E-4 Oz.
8.00	R19.5	D-6 Oz.
9.00	R19.5	D-6 Oz.
18.00	R19.5	W-16 Oz.
225/70	R19.5	D-6 Oz.
245/70	R19.5	D-6 Oz.
265/70	R19.5	D-6 Oz.
275/70	R19.5	C-8 Oz.
285/70	R19.5	C-8 Oz.
295/70	R19.5	C-8 Oz.
305/70	R19.5	B-10 Oz.
280/75	R19.5	C-8 Oz.
445/65	R19.5	W-16 Oz.
525/65	R20.5	B+C+C=26 Oz.
615/65	R20.5	A+A+B=34 Oz.
7.50	R20	C-8 Oz.
8.25	R20	C-8 Oz.
9.00	R20	B-10 Oz.
10.0	R20	B-10 Oz.
11.00	R20	A-12 Oz.
12.00	R20	A-12 Oz.
12.50	R20	A-12 Oz.
13/80	R20	A-12 Oz.
14/80	R20	B+E=14 Oz.
14.00	R20	W-16 Oz.
16.00	R20	B+B=20 Oz.
10.00	R22	B-10 Oz.
11.00	R22	A-12 Oz.
9.00	R22.5	C-8 Oz.
10.00	R22.5	B-10 Oz.
11.00	R22.5	B-10 Oz.
12.00	R22.5	A-12 Oz.
275/50	R22.5	B-10 Oz.
235/70	R22.5	D-6 Oz.
255/70	R22.5	C-8 Oz.
11/70	R22.5	B-10 Oz.
265/70	R22.5	C-8 Oz.
295/60	R22.5	B-10 Oz.
275/70	R22.5	B-10 Oz.

TIRE SIZE	WHEEL POSITION	
	SINGLE	DUAL
TRUCK TIRES		
305/70	R22.5	B-10 Oz.
365/70	R22.5	B+E=14 Oz.
315/70	R22.5	B-10 Oz.
245/75	R22.5	C-8 Oz.
265/75	R22.5	C-8 Oz.
285/75	R22.5	B-10 Oz.
295/75	R22.5	B-10 Oz.
315/75	R22.5	A-12 Oz.
345/75	R22.5	A-12 Oz.
350/75	R22.5	B+E=14 Oz.
235/80	R22.5	D-6 Oz.
255/80	R22.5	C-8 Oz.
275/80	R22.5	B-10 Oz.
295/80	R22.5	A-12 Oz.
305/85	R22.5	A-12 Oz.
315/80	R22.5	A-12 Oz.
365/80	R22.5	B+E=14 Oz.
445/50	R22.5	W-16 Oz.
455/50	R22.5	W-16 Oz.
385/65	R22.5	A-12 Oz. hwy
425/65	R22.5	W-16 Oz.
435/45	R22.5	B+E=14 Oz.
445/55	R22.5	W-16 Oz.
445/65	R22.5	W-16 Oz.
495/45	R22.5	W-16 Oz.
15.00	R22.5	A-12 Oz. hwy
16.50	R22.5	W-16 Oz.
18.00	R22.5	W-16 Oz.
11.00	24	A-12 Oz.
12.00	24	B+E=14 Oz.
14.00	24	W-16 Oz.
285/75	R24.5	B-10 Oz.
305/75	R24.5	A-12 Oz.
315/75	R24.5	A-12 Oz.
275/80	R24.5	B-10 Oz.
295/80	R24.5	B-10 Oz.
11.00	R24.5	B-10 Oz.
12.00	R24.5	A-12 Oz.



FLEXX
MORE MILES. LESS FUEL

CAMBER/CASTER TOOLS



HEAVY DUTY TRUCK ALIGNMENT SHIMS

• 1990 & newer Freightliner single slot adjustment shim • **INCLUDES:** 12 pieces per package

Ascot No.	Mfg. No.	Description
246-43415	43-415	1/32"
246-43416	43-416	1/16"
246-43417	43-417	1/8"



246-43415

IHC TORQUE ARM ADJUSTMENT SHIMS

• **INCLUDES:** 12 pieces per package

Ascot No.	Mfg. No.	Description
246-43441	43-441	1/32"
246-43442	43-442	1/16"
246-43443	43-443	1/8"

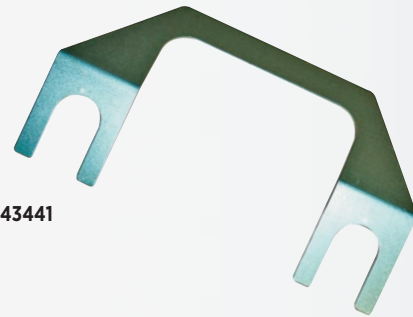

246-43441

HENDRICKSON ADJUSTABLE WALKING BEAM SHIM KIT

• **INCLUDES:** 2x 5-Piece Kits • Each kit contains 2 of 1/8", 1 of 1/16" & 2 of 1/32"

Ascot No.	Mfg. No.	Description
246-43447	43-447	Hendrickson Adjustable Walking Beam Shim Kit



246-43447

HEAVY DUTY TRUCK ALIGNMENT SHIMS

• Kenworth air glide 8-bagger adjustment spacers • **INCLUDES:** 6 shims per package

Ascot No.	Mfg. No.	Description
246-43548	43-548	1/32"
246-43549	43-549	1/16"
246-43550	43-550	1/8"
246-43551	43-551	1/4"
246-43552	43-552	1/2"
246-43553	43-553	3/4"
246-43554	43-554	1"

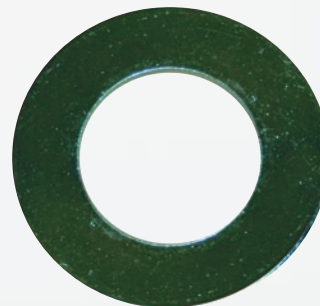

246-43548



HEAVY DUTY ALIGNMENT



TRUCK AXLE SHIMS (HEAVY DUTY ZINC ALLOY)

- **Twice the coverage with half the inventory, these truck axle shims fit a variety of 2WD and 4WD vehicles with solid axles from full size Blazers to school buses** • Measure the spring pad, break the shim off at the correct width and insert between the spring and axle • Available in 1/2° changes up to a 4° caster change, either positive or negative • **Packaged six per box** • Any solid axle 2 or 4 wheel drive vehicle



243-00891

Ascot No.	Mfg. No.	Width	Degree Taper
243-00891	89199	3"-3-1/2"-4"	1/2°
243-00892	89299	3"-3-1/2"-4"	1°
243-00893	89399	3"-3-1/2"-4"	1-1/2°
243-00894	89499	3"-3-1/2"-4"	2°
243-00895	89599	3"-3-1/2"-4"	2-1/2°
243-00896	89699	3"-3-1/2"-4"	3°
243-00897	89799	3"-3-1/2"-4"	3-1/2°
243-00898	89899	3"-3-1/2"-4"	4°

TRUCK AXLE SHIMS (HEAVY DUTY ZINC ALLOY)

- **One part number gives you six shims in a box**

243-00841



Ascot No.	Mfg. No.	Width	Degree Tapaer	Box Wt.
243-00841	84199	2-1/4"- 2-1/2"	1/2°	1-1/2 Lbs.
243-00842	84299	2-1/4"- 2-1/2"	1°	1-1/2 Lbs
243-00843	84399	2-1/4"- 2-1/2"	1-1/2°	2 Lbs.
243-00844	84499	2-1/4"- 2-1/2"	2°	2-1/4 Lbs.
243-00845	84599	2-1/4"- 2-1/2"	2-1/2°	2-3/4 Lbs.
243-00846	84699	2-1/4"- 2-1/2"	3°	2-3/4 Lbs.
243-00847	84799	2-1/4"- 2-1/2"	3-1/2°	3-1/4 Lbs.
243-00848	84899	2-1/4"- 2-1/2"	4°	3-1/4 Lbs.

KENWORTH AIR GLIDE SPACER FOR EIGHT BAGGERS

Ascot No.	Mfg. No.	Thickness	Qty.
241-35001	35001	1/32"	6
241-35002	35002	1/16"	6
241-35003	35003	1/8"	6
241-35004	35004	1/4"	6
241-35005	35005	1/2"	6
241-35006	35006	3/4"	6
241-35007	35007	1"	6



TANDEM ALIGNMENT SET

- **GREAT STARTER KIT!** • These alignment angle shims are now available in a heavy duty metal box to help you organize all of your shims • Packaged with a large variety of shims and an organization chart inside the lid to make reordering and organization of shims quick and easy



246-36000

Ascot No.	Mfg. No.	Description
246-36000	36000	Tandem Alignment Set

TRUCK AXLE SHIMS

- **Packaged six per box**
- Spring pad length and width is needed when placing orders
- **Installation time: .5 hr./side**

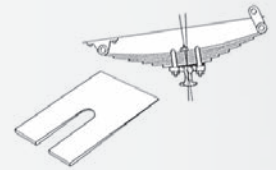

Ascot No. Bronze	Mfg. No. Bronze	Ascot No. Aluminum	Mfg. No. Aluminum	Width	Degree	Length
241-04050	10404	241-04051	10405	2-1/2"	1/2°	5"
241-10410	10414	241-10411	10412	2-1/2"	1°	5"
241-10420	10424	241-10421	10422	2-1/2"	1-1/2°	5"
241-10430	10434	241-10431	10432	2-1/2"	2°	5"
241-10440	10444	241-10441	10442	2-1/2"	2-1/2°	5"
241-10450	10454	241-10451	10452	2-1/2"	3°	5"
241-10460	10464	241-10461	10462	2-1/2"	3-1/2°	5"
241-10470	10474	241-10471	10472	2-1/2"	4°	5"
241-05050	10504	241-05051	10505	3"	1/2°	6"
241-10510	10514	241-10511	10512	3"	1°	6"
241-10520	10524	241-10521	10522	3"	1-1/2°	6"
241-10530	10534	241-10531	10232	3"	2°	6"
241-10540	10544	241-10541	10542	3"	2-1/2°	6"
241-10550	10554	241-10551	10552	3"	3°	6"
241-10560	10564	241-10561	10562	3"	3-1/2°	6"
241-10570	10574	241-10571	10572	3"	4°	6"
241-06050	10604	241-06051	10605	3-1/2"	1/2°	6-1/4"
241-10610	10614	241-10611	10612	3-1/2"	1°	6-1/4"
241-10620	10624	241-10621	10622	3-1/2"	1-1/2°	6-1/4"
241-10630	10634	241-10631	10632	3-1/2"	2°	6-1/4"
241-10640	10644	241-10641	10642	3-1/2"	2-1/2°	6-1/4"
241-10650	10654	241-10651	10652	3-1/2"	3°	6-1/4"
241-10660	10664	241-10661	10662	3-1/2"	3-1/2°	6-1/4"
241-10670	10674	241-10671	10672	3-1/2"	4°	6-1/4"
241-07050	10704	241-07051	10705	4"	1/2°	6-1/2"
241-10710	10714	241-10711	10712	4"	1°	6-1/2"
241-10720	10724	241-10721	10722	4"	1-1/2°	6-1/2"
241-10730	10734	241-10731	10732	4"	2°	6-1/2"
241-10740	10744	241-10741	10742	4"	2-1/2°	6-1/2"
241-10750	10754	241-10751	10752	4"	3°	6-1/2"
241-10760	10764	241-10761	10 762	4"	3-1/2°	6-1/2"
241-10770	10774	241-10771	10772	4"	4°	6-1/2"
-	-	241-10781	10782	4"	5°	6-1/2"



HEAVY DUTY ALIGNMENT



PETERBILT AIR LEAF ADJUSTING SHIM

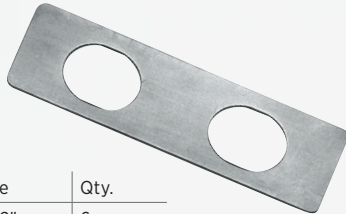

Ascot No.	Mfg. No.	Size	Qty.
246-35010	35010	1/32"	6
246-35011	35011	1/16"	6
246-35012	35012	1/8"	6

246-35010

FREIGHTLINER ADJUSTING SHIMS

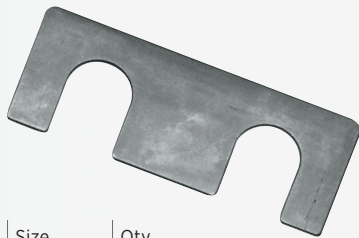

Ascot No.	Mfg. No.	Size	Qty.
246-35020	35020	1/32"	6
246-35021	35021	1/16"	6
246-35022	35022	1/8"	6

246-35020

VOLVO/WHITE TANDEM SHIMS

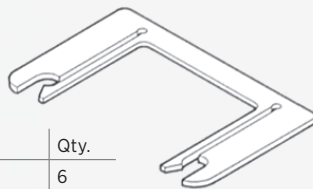

Ascot No.	Mfg. No.	Size	Qty.
246-35030	35030	1/32"	6
246-35031	35031	1/16"	6
246-35032	35032	1/8"	6

246-35030

I.H.C. TORQUE ARM SHIMS

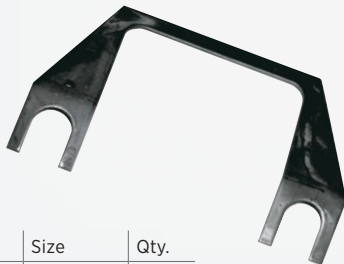

Ascot No.	Mfg. No.	Size	Qty.
246-35040	35040	1/32"	6
246-35041	35041	1/16"	6
246-35042	35042	1/8"	6

246-35040

SINGLE SLOT TANDEM TRUCK SHIMS



• Universal shims are installed at the ends of torque rod to change toe and/or thrust angles on Freightliner, Hendrickson and Navistar heavy duty tandem trucks and trailers

Ascot No.	Mfg. No.	Size	Qty.
246-35060	35060	1/32"	6
246-35061	35061	1/16"	6
246-35062	35062	1/8"	6

246-35060

FREIGHTLINER SHIMS FOR AIR GLIDE SUSPENSION



• Over-the-road heavy duty adjusters for fast and accurate means to align front or rear axles of popular tandem trailers and trucks • Reliable means to complete total heavy duty truck alignments

Ascot No.	Mfg. No.	Size	Qty.
246-35070	35070	1/32"	6
246-35071	35071	1/16"	6
246-35072	35072	1/8"	6

246-35070

PETERBILT/KENWORTH FLEX AIR SUSPENSION SHIMS



• Adjust thrust angle and toe by shimming the torque arms

Ascot No.	Mfg. No.	Size	Qty.
246-36010	36010	1/32"	6
246-36011	36011	1/16"	6
246-36012	36012	1/8"	6

246-36010



HENDRICKSON WALKING BEAM SHIMS

- O.E. style shims recommended by Hendrickson
- Offers three adjustments of 0, 3/16" and 3/8"



Ascot No.	Mfg. No.	Qty.
241-36080	36080	2
241-36085	36085	2

HENDRICKSON HD SHIMS

- Shim kit will adjust the thrust angle on Hendrickson's "walking beam" rear tandem axle suspension • Improves tire wear and handling by adjusting thrust angle from 0" to 3/8" in precise 1/32" increments • **INCLUDES:** 2 (two)-five piece kits • Requires one set per wheel

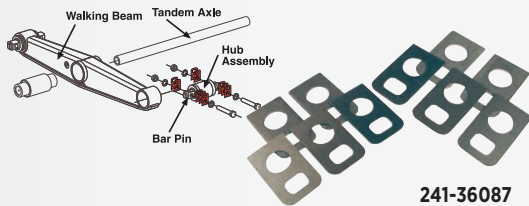

241-36087

Ascot No.	Mfg. No.	Description
241-36087	36087	Hendrickson HD Shims

TIRE MATING SQUARE

- Checks for variance in dual tire mating
- Compare tire size by placing long arm against the side wall and short arm against tread



247-18440

Ascot No.	Mfg. No.	Description
247-18440	91844	LENGTH: Long Arm 48", Short Arm 26"

TOE BAR WITH SCRIBE

- Gives toe readings (in 1/32 of an inch increments) by measuring distances between marks scribed at the center of the tire treads • **INCLUDES:** 8 ft. bar, 17 in. pointers, 5 in. stands and #WA516 scribe • Reliable means to complete total heavy duty truck alignments



246-51100

Ascot No.	Mfg. No.	Description
246-51100	99511	For Cars and Light Trucks
247-51200	99512	For Trucks, Buses, RVs, Vans

TRUCK FRONT SLIP PLATE SET (PAIR)

- Used in conjunction with the WA515 toe gauge
- **Steel slip plates allow the tire to move freely while the technician sets the toe**



247-18410

Ascot No.	Mfg. No.	Description
247-18410	91841	16" x 24" x 3/8"

TRAILER TANDEM TRACKER

- Used to aid in measuring the tracking of tandem axles in relationship to the kingpin suspensions and the front and rear axles on the tandem • Establishes a measuring point from the center of the wheel



246-18880

Ascot No.	Mfg. No.	Description
246-18880	91888	Trailer Tandem Tracker Set (Pair)

TANDEM AXLE CALIPER

- Used to check the spacing between the axles of tractors or trailers for alignment and tracking
- Easy to read scale in both metric and inches, with a range of 72"

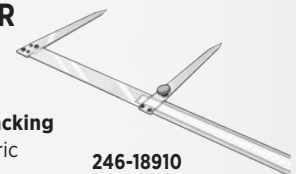

246-18910

Ascot No.	Mfg. No.	Description
246-18910	91891	Tandem Axle Caliper



HEAVY DUTY ALIGNMENT



LO PROFILE EXTENDER BARS

• The 91887 Lo Profile Extender Bar is designed to lower the measuring point of the tandems from the hub so that measuring the tracing of low profile trailers, such as car carriers and moving vans can be easily done • Can be used with either the 91888 or the 91890 • Sold in pairs

Ascot No.	Mfg. No.	Description
247-91877	91877	Lo Profile Extender Bars



TANDEM ALIGNMENT SYSTEMS - STEEL WHEELS

• This is a simple method for tracking the rear dual tandems on trucks and tractors • INCLUDES: The 91896 "U" Bolt Extensions, a pair of Lo Profile Extension Bars (91877) and a pair of 91888 Tandem Trailer Trackers • With this system the technician can easily check the A and D distances along with the B and C distances to see if the tandems are tracking correctly



Ascot No.	Mfg. No.	Description
247-91988	91988	Tandem Alignment Systems - Steel Wheels

S-CAM BUSHING EXTRACTOR

• Great tool for any Heavy Duty shop that works on low boys, reefers, log trucks and more
 • Now you can remove and replace the S-Cam bushing on air brake equipped trailers without removing the wheel hub or replacing the wheel seal • Save time and money yourself and for your customer with this innovative durable tool
 • Offer S-Cam replacement with every brake job!



Ascot No.	Mfg. No.	Description
247-91860	91860	S-Cam Bushing Extractor

TANDEM ALIGNMENT SYSTEMS - ALUMINUM WHEELS

• The 91990 is a simple method for tracking the rear dual tandems on trucks and tractors • INCLUDES: The 91896 "U" Bolt Extensions, a pair of Lo Profile Extension Bars (91877) and a pair of 91890 Tandem Tracker Set for Aluminum Wheels • With this system the technician can easily check the A and D distances along with the B and C distances to see if the tandems are tracking correctly

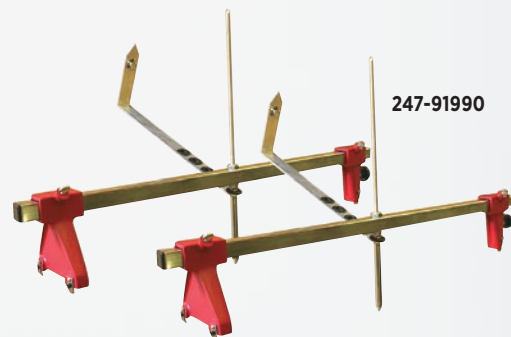

Ascot No.	Mfg. No.	Description
247-91990	91990	Tandem Alignment Systems - Aluminum Wheels

"U" BOLT EXTENSIONS

• This extension set is used to measure the tandem axles on tractors in relationship to the front spring "U" bolts • The extenders establish a measuring point on the front axles so you can make accurate measurements to the rear axle • Measurements "A" and "D" should be equal as well as measurements "B" and "C" if the vehicle is tracking correctly on the front axle • Includes four extenders - two with 3/4" threads and two with 7/8" threads • Use with 91877 or 91889 and 91888 or 91890



Ascot No.	Mfg. No.	Description
247-91896	91896	"U" bolt Extensions (4)



HEAVY DUTY & OTR TOE BAR SET

• **INCLUDES:** 10" extra-high stands, two standard 11" pointers, two long 17" pointers, an 8 ft. bar and 99516 scribe



Ascot No.	Mfg. No.	Description
247-99515	99515	Heavy Duty & OTR Toe Bar Set

TOE BAR SET FOR LIGHT TRUCKS

• **INCLUDES:** everything in the 99515 Toe Bar Set plus an additional pair of 5" stands



Ascot No.	Mfg. No.	Description
247-99517	99517	Toe Bar Set for Light Trucks

AIR BLADDER CAMBER ADJUSTING TOOL

• **Air-assisted, multiple camber adjustment tool makes camber adjustment on many GM and Chrysler vehicles easier** • Simply loosen the strut mount bolts, place the adjuster between the tire and strut, and inflate • To adjust camber slowly release the air until the wheel retracts to the specified alignment setting, tighten bolts and the alignment is done • **INCLUDES:** A specially designed, puncture resistant air bladder, 2' air hose, a low pressure pop-off valve to prevent overinflating and an air control valve for inflating and controlled deflating



228-61400

Ascot No.	Mfg. No.	Description
228-61400	DOWTC614	Air Bladder Camber Adjusting Tool

H/D STEEL WHEEL RIM STRAIGHTENING TOOL

• **For quick and easy removal of indentations on wheel flanges and rims of most vehicles** • Allows proper tire seating, giving greater tire protection and durability • Powder coated for added durability



247-08130

Ascot No.	Mfg. No.	Description
247-08130	81309	H/D Steel Wheel Rim Straightening Tool

RADIAL RUNOUT GAUGE

Radial runout is an out of round condition in which the radius of the wheel or tire is not consistent from the wheel center to any point on the rim or the tread. Tire and wheel radial runout are often factors in troubleshooting ride and handling and in maintaining correct wheel balancing to reduce vibration.

• **Measures vehicle vibration sensitivity** • Measures out of round condition • **EASY TO USE:** only 2 adjustments • Pinpoints high or low spots in the tire • Determines accurate centering of tire and wheel mounting



247-33173

Ascot No.	Mfg. No.	Description
247-33173	64250	Radial Runout Gauge



BATTERY CHARGERS & TESTERS



PROSERIES 12V 2200 PEAK AMP JUMP STARTER WITH USB AND DC POWER

• **POWERFUL PERFORMANCE: 525 CA, 350 CCA** • High output AGM battery • 2A external automatic charger • 2.1A USB port • 12V DC outlet • Digital display • ON/OFF switch • Reverse connection warning • Schu Eco Energy: Meets the highest industry standards



341-00114

Ascot No.	Mfg. No.	Description
341-00114	DSR114	ProSeries 12V 2200 Peak Amp Jump Starter with USB and DC Power

6/2/40/20/250/125A 12/24V AUTOMATIC BATTERY CHARGER/ENGINE STARTER

• **250A/12V AND 125A/24V ENGINE START:** Powerful enough for SUVs, trucks and large engines • **40A OR 20A BOOST MODE:** Quickly brings deeply discharged batteries back to life • **MULTI-FUNCTION BATTERY TESTER:** For battery status and charging system analysis • **MICROPROCESSOR-CONTROLLED:** Automatically adjusts amperage rate, to charge and maintain • **MULTI-STAGE CHARGING:** For added precision, safety and battery life • **FLOAT MODE MONITORING:** Maintains optimum battery charge • Auto voltage detection • Reverse hook-up protection • **SCROLLING DIGITAL DISPLAY:** Gives step-by-step instructions to properly charge your battery • LED indicators and push-button controls • **4-GAUGE OUTPUT CABLES:** Stay flexible in cold weather • Clamps and cords on front of unit • Convenient clamp rest in handle • Compact wheels for easy storage • **SCHU ECO ENERGY:** Meets the highest industry standards

PROSERIES 1800 PEAK AMP JUMP STARTER

Jump Starter + 12V DC power source

• **OUTPUT CURRENT (PEAK): 1800A** • **DIMENSIONS:** 8.25" x 12.38" x 12" • **WEIGHT:** 19.59 lb. • **WARRANTY PERIOD:** 1 year • **800 PEAK AMPS:** Power for jump starting vehicles in emergencies • **BUILT-IN CHARGER:** For automatic charging of internal battery • **LED INDICATORS:** For charging and status of internal battery • Maintenance-free, sealed lead-acid AGM battery • 12V DC power outlet with overload and short-circuit protection • Heavy-duty clamps fit both top- and side-mount batteries • 4-gauge, 28" flex performance cable • Compact, durable and corrosion-proof polypropylene case • **SCHU ECO ENERGY:** Meets the highest industry standards



341-00119

Ascot No.	Mfg. No.	Description
341-00119	DSR119	ProSeries 1800 Peak Amp Jump Starter



341-01352

Ascot No.	Mfg. No.	Description
341-01352	SC1352	6/2/40/20/250/125A 12/24V Automatic Battery Charger/Engine Starter



BENCH GRINDERS & SHOP VISES



6" SWIVEL BASE BENCH VISE

- Heavy duty 30,000 PSI castings for long life and added strength • Swivel bar rotates 360° and has double lockdowns ensuring maximum stability • Powder coat paint resists scratches and provides a tough durable finish
- Replaceable hardened steel top and pipe jaws



311-21500

Ascot No.	Mfg. No.	Jaw Width	Throat Depth	Pipe Cap.	Wt.
311-21500	21500	6"	4-1/8"	1/4 - 3-1/2"	69.35 lb.

TRADESMAN VISES

- Fully sealed one-piece spindle nut assembly for a lifetime of smooth operation
- Precision machined slide bar to eliminate movement in front jaw regardless of opened position
- 60,000 PSI ductile iron body, jaw & base
- Machined steel serrated jaws with black phosphate coating for increased durability and corrosion resistance • Lifetime Warranty



311-28806

Ascot No.	Mfg. No.	Jaw Width	Opening Capacity Max.	Throat Depth	Pipe Jaw Capacity	Weight
311-28805	28805	4-1/2"	3-1/2"	3-1/2"	1/4" - 3-1/2"	42 lb.
311-28806	28806	5-1/2"	5"	3-5/8"	3/8" - 3-1/2"	42 lb.
311-28807	28807	6-1/2"	6"	4-1/4"	3/8" - 4"	42 lb.
311-28808	28808	8"	6-3/4"	5"	3/8" - 4-1/2"	111 lb.

MECHANICS PRO VISES

- Enclosed Spindle for smooth operation • Precision machined slide bar to eliminate movement in front jaw regardless of opened position • Needle roller thrust bearing to easily apply and release clamping force • 60,000 PSI Jaw and Base • Lifetime Warranty



311-28811



Ascot No.	Mfg. No.	Jaw Width	Opening Capacity Max.	Throat Depth	Pipe Jaw Capacity	Weight
311-28810	28810	4-1/2"	4"	3-1/2"	1/4" - 3"	31 lb.
311-28811	28811	5-1/2"	5"	3-5/8"	1/4" - 3"	38 lb.
311-28812	28812	6-1/2"	6"	4-3/8"	1/4" - 4"	56 lb.
311-28813	28813	8"	8-1/2"	4-1/2"	1/2" - 4"	83 lb.
311-28814	28814	10"	12"	5-1/4"	1/2" - 5"	115 lb.

PROFESSIONAL SHOP VISES

- Cast iron jaw with heavy internal ribs for added strength. Pipe jaws are permanently cast in for greater channel strength
- Cast iron back jaw designed for exceptional alignment with the front jaw • "V" notched, replaceable/reversible jaws made of carbon steel and heat treated for extra strength
- Specially designed spring loaded handle and screw guarantees quick jaw response
- Front jaw beam covers and protects screws • Steel handle balls forged from handle stock
- Lifetime Casting Warranty



311-64055

Ascot No.	Mfg. No.	Jaw Width	Jaw Opening	Throat Depth	Pipe Jaw Capacity	Weight
311-64055	64055	5-1/2"	6-1/2"	3-3/16"	1/8"	30 lb.
311-64065	64065	6-1/2"	7-1/2"	3-3/4"	1/8"-2-1/2"	41 lb.
311-64650	64650	6-1/2"	7"-10"	3-3/16"	1/8"-2-1/2"	50 lb.
311-64800	64800	8"	8"-11"	3-3/4"	1/8"-3"	74 lb.



PLIERS & SCREWDRIVERS



7" CUTTING PLIER WITH END CUTTER

- Perfectly mated cutter, heat treated to hold its edge • Polished high carbon drop forged steel • CHANNELLOCK BLUE® comfort grips



319-00357

Ascot No.	Mfg. No.	Description
319-00357	357	7" Cutting Plier with End Cutter

6" DIAGONAL CUTTING PLIER, BOX JOINT

- Perfectly mated cutter, heat treated to hold its edge • Polished, high carbon drop forged steel • Distinctive CHANNELLOCK BLUE® comfort grips



319-00436

Ascot No.	Mfg. No.	Description
319-00436	436	6" Diagonal Cutting Plier, Box Joint

5" CUTTING PLIER, BOX JOINT

- Perfectly mated cutters, scientifically heat treated to hold their edge • Precision made of fine polished, high carbon drop forged steel • Distinctive CHANNELLOCK BLUE® comfort grips



319-00435

Ascot No.	Mfg. No.	Description
319-00435	435	5" Cutting Plier, Box Joint

6" SLIP JOINT PLIER, WIRE CUTTING SHEAR

- Thick Nose Pliers • Shear-type wire cutter • Precision made of fine polished, high carbon drop forged steel • Patented PermaLock® fastener eliminates nut and bolt failures • CHANNELLOCK BLUE® comfort grip



319-00526

Ascot No.	Mfg. No.	Description
319-00526	526	6" Slip Joint Plier, Wire Cutting Shear

CHANNELLOCK PLIERS

- 100% MADE IN USA
- LASER heat-treated cutting edges perform better and last longer
- FORGED high carbon U.S. steel for maximum strength and durability is specially coated for ultimate rust prevention
- CHANNELLOCK BLUE® grips for comfort



319-00358

Ascot No.	Mfg. No.	Description
319-00358	358	8" End Cutting Plier

8-PIECE PROFESSIONAL SCREWDRIVER SET

- Includes 5 flat tip drivers and 3 Phillips tip drivers: SLOTTED: 3/8" x 8", 5/16" x 6", 1/4" x 4", 3/16" x 3", 1/4" x 1-1/2" • PHILLIPS: #2 Phillips x 4", #1 Phillips 3", #2 Phillips x 1-1/2" • Black handles • Hardened chrome vanadium shafts • Vapor blasted magnetic tips • Packaged in molded plastic tray for storage • Hex bolsters for extra turning power



319-19800

Ascot No.	Mfg. No.	Description
319-19800	19800	8-Piece Professional Screwdriver Set

SHOP CLEANERS & BRUSHES



PREMIUM HAND WIPES

Winntec's premium hand wipes are the perfect way to keep clean in any workshop.

- **Powerful cleaning**
- Moisturizing • Great for hands and surfaces • Water saving • 336 wipes per box



395-83039

Ascot No.	Mfg. No.	Description
395-83039	G083039	Premium Hand Wipes



SURFACE PREP & CLEANING WIPES

- **Wheel cleaner compatible with adhesive wheel weights** • Safe for all clear coated wheels
- Fast acting, No rinse required
- **Ideal for use as a multi-purpose cleaner on car interior & exterior** • Professional strength performance removes dirt, grease and brake fluid from wheels, windows, tools, shop equipment, floors & many other surfaces
- **300 wipes per bucket, 6 buckets per case**



Ascot No.	Mfg. No.	Description
486-21638	21638-5426300	Surface Prep & Cleaning Wipes (For Adhesive Wheel Weights)

FLOOR SQUEEGEES

- **Black neoprene rubber blade designed for rough, heavy use** • Handle not included, order separately



395-45507

PALMYRA FILL GARAGE BRUSHES/ BROOMS

- **Excellent for heavy duty sweeping of concrete, sidewalks and garage floors** • Can be used for wet or dry sweeping



395-42023

Ascot No.	Mfg. No.	Description	Ascot No.	Mfg. No.	Description
395-45507	45507	24" Straight Squeegee	395-42023	42023	24" Garage Brush- Palmyra
395-44020	44020	Handle			

PLASTIC HANDLED BRASS SIDEWALL BRUSH

- **Densely packed brass bristles** • Great for cleaning white sidewall tires • **BRISTLE LENGTH: 3/4"** • **OVERALL LENGTH: 8-1/4"** • Plastic handle fits comfortably in the hand



395-13124

Ascot No.	Mfg. No.	Description
395-13124	VT-932	Plastic Handled Brass Sidewall Brush

WOODEN HANDLED WIRE BRUSH WITH METAL SCRAPER

- **Cleans rust from rims and wheels** • 19 rows of steel bristles • Slightly curved wooden handle • *Metal scraper included* • **BRISTLE LENGTH: 1"** • **OVERALL LENGTH: 14-1/4"**



535-00150

Ascot No.	Mfg. No.	Description
535-00150	VT-931	Wooden Handled Wire Brush with Metal Scraper

SHOP CLEANERS & BRUSHES



GOJO® SUPRO MAX™ HAND CLEANER

- Effective on oil, grease, paint, and adhesives
- Unique blend of cleaners and skin conditioners help leave skin feeling healthy
- Non-drying formula



395-72724

395-72722

GOJO® NATURAL* ORANGE™ PUMICE HAND CLEANER

- Effective on dirt, oil and grease
- Quick-acting, lotion hand cleaner with pumice scrubbers

*Natural citrus ingredient



395-72554

395-72552

Ascot No.	Mfg. No.	Description
395-72722	7272-D2	PRO™ TDX™ 2000 Starter Kit (1 Dispenser, 1 Refill)
395-72724	7272-04	2000 mL Refill (4 per case)

Ascot No.	Mfg. No.	Description
395-72552	7255-D2	PRO™ TDX™ 2000 Starter Kit (1 Dispenser, 1 Refill)
395-72554	7255-04	2000 mL Refill (4 per case)
395-09552	0955-02	2x 1-Gallon Pump Bottles



FULL BORE HAND CLEANER

- Rids hands of dirt and grease while leaving the skin soft and chap free
- Solvent free
- Economical
- Contains skin moisturizers
- Clean fragrance
- Never irritates or burns open wounds
- Rinses clean
- Keeps your sink clean
- Keeps your pipes clean
- Will not separate during hot months
- Long shelf life
- Neutral pH
- MEETS AMERICAN CLEAN WATERS ACT



395-40000

395-00101

395-00102

395-00103

395-00400

395-06400

395-06401

395-00126

395-00104

Ascot No.	Mfg. No.	Description
ULTRA FLOW		
395-00101	TS1GAL	Ultra Flow, 1 Gallon
395-00102	TS1GAL-FT	Ultra Flow, 1 Gallon Flat Top
395-00103	TS1GAL-16OZ	Ultra Flow, 16 oz. **
ULTRA FLOW DISPENSERS		
395-00104	Plastic Pump	Plastic Pump
395-00300	TS300-D	Stainless Steel Screw On Dispenser **
395-00125	TS125-D	Stainless Steel Wall Mount Dispenser
395-00126	TS125-FT-D	Stainless Steel Wall Mount Dispenser (Fits Flat Top)
SUPER GRIT		
395-40000	TS4000	Super Grit, 4 Gallon **
395-06400	TS6400	Super Grit, 64 oz.
EXTREME GREEN		
395-00400	MG-HS-4GAL	Extreme Green, 4 Gallon **
395-06401	MG-HS-64OZ	Extreme Green, 64 oz.

SERVICE STICKERS



STATIC CLING PRINTER

• Full feature Reminder Sticker Solution takes professionalism to a new level • Godex Printer pre-programmed to work out of the box • 1 year parts and labor warranty (6 months on print head) • Includes 1 ribbon



399-11111

Ascot No.	Mfg. No.	Description
399-11111	FK-GX001-05	Static Cling Printer

STATIC CLING REMINDER STICKERS

• Excellent item to promote repeat business • Keeps your name, the service to be done and the time to do it in constant view of the customer • More effective than a door jam sticker • Static cling vinyl will cling to almost any smooth surface • No adhesive residue and they can be removed for cleaning and replacing • Silk screen printing process for a high quality image and a writing strip that won't allow the ink to fade • Generic design stickers as well as personalized stickers



399-00101



399-00102



399-00103

Ascot No.	Description
399-00101	Air Pressure/Tire Rotation Static Cling Sticker
399-00102	Oil Change Static Cling Sticker
399-00103	Service Reminder Static Cling Sticker



INTERIOR PROTECTION PRODUCTS



The Slip-N-Grip® protection system provides total protection for the customer's car while being serviced:

- Covers hold fast to the upholstery: A patented process laminates two distinctly different plastics together - the top layer allows a person to easily slide into and out of the vehicle and the bottom, or gripping layer, keeps the seat cover in place
- Unique process eliminates static electric clinging and wrinkling.

A complete line of vehicle interior protection products are available along with a service center roll dispenser.



399-99302

PARTS RETURN BAG

- **Heavy plastic bag for holding old removed parts you've replaced** • Keeps customer's vehicle and hands clean

Ascot No.	Mfg. No.	Description	Size
399-60098	FB-P9943-56	Parts Return Bag	14" x 22"

WORK TICKET HOLDER

- **Heavy-duty sewn nylon fabric handle ensures durability even in harsh conditions** • Durable brass grommet increases strength

Ascot No.	Mfg. No.	Description	Size	Qty.
399-99302	FB-P9933-02	Work Ticket Holder	10.5" x 14.5"	25/box

PAPER KEY TAG

- **Cost-effective, convenient solution for key control** • Metal ring

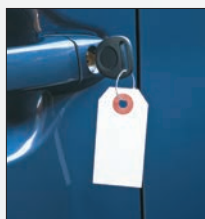

399-98313



Ascot No.	Mfg. No.	Description	Size	Qty.
399-98313	FB-P9833-13	Paper Key Tag with Metal Rings	1.5" x 2.75"	1,000/box

PLASTIC FLOOR MAT

- **Slip-N-Grip® two-layer construction ensures plastic floor mat stays in place**
- Impervious to water, oil, grease and most shop chemicals

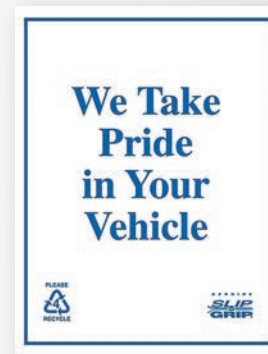

399-99432

Ascot No.	Mfg. No.	Description	Qty.
399-99432	FG-P9943-02	Plastic Floor Mat	500/roll

PLASTIC KEY TAG

- **Self-locking design holds keys secure** • Large writing surface; holes are fully punched out eliminating "chads"
- Perfect for quickly tagging keys in a busy service area



399-99323

Ascot No.	Mfg. No.	Description	Qty.
399-99323	FB-P9933-23	White Plastic Key Tag - 4.5" x .75"	1000/package

GENERIC ADHESIVE TIRE LABEL

- **Features sure-grip adhesive** • Proper used tire labeling sells tires • These labels will catch your customer's eye and promote sales

Ascot No.	Mfg. No.	Description	Qty.
399-99479	FB-P9943-79	Generic Adhesive Tire Label - 3" x 6"	500/roll

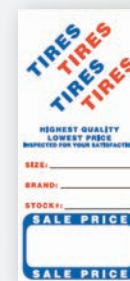

399-99479



PERSONALIZED PAPER FLOOR MATS

- Either insert your logo where the footprints are or totally design a new layout
- The stock is a high bulk 60 pound white sheet, size 17" x 22", with a one color imprint
- Minimum order of 3,000
- Camera ready art must be supplied for all logos
- one time artwork charge



399-00005

Ascot No.	Description
399-00005	Personalized Paper Floor Mats

PRIME HEAVY DUTY PAPER FLOOR MATS

- Treated/coated mats, made from premium prime/virgin paper
- Keeps dirt, grease, oil, spills, leaks and other shop fluids out of your customer's vehicle during service
- Prime paper is suitable for all weather climates and heavy foot traffic
- Prime paper directly from paper mill provides same consistent quality every time
- Printed with UV ink
- Bright white paper produces vibrant, full color prints
- Recyclable
- **SIZE:** 17" x 19"
- **QUANTITY:** 500 per box



399-74980



Prime Heavy Duty Paper Floor Mat in use.

Ascot No.	Mfg. No.	Description
399-74980	M3273PP2280A	Prime Heavy Duty Paper Floor Mats - 17" x 19"

PLASTIC ARROW KEY TAG

- Unique one piece key tag that attaches easily to the key ring with a hole for hanging on a board
- Packaged 40 perforated sheets with 25 tags each
- 1000 per pack

Ascot No.	Description
399-00011	Plastic Arrow Key Tag

TIRE LABELS

- 2-1/2" x 6" label for easy identification of new, used and retreaded tires
- Packed 500 per roll



601-00101

Ascot No.	Mfg. No.	Description
601-00101	TL-101	Tire Labels New-Used-Retread

STEERING WHEEL COVER

- Keeps grease, dirt and other shop chemicals off of one of the most noticeable and expensive parts of the car
- Reusable/disposable steering wheel covers are made of clear polyethylene with stretch elastic grip feature
- Elastic design is easier to apply and remove than stretch wrap covers
- Unique double-band steering wheel covers stays in place while allowing access to airbags



399-99433

Ascot No.	Mfg. No.	Description
399-99433	M-FB-P9943-33	Standard Size Double Band Steering Wheel Cover: <ul style="list-style-type: none"> • Size: 5" wide • Fits up to 24" Steering Wheel up to 15.2" in diameter • Covers virtually all passenger cars and light trucks • Quantity: 500 per box

TIRE DISPLAYS, RACKS & CARTS



FLOOR-RACK START-UP KIT

• Promotes your professional image by displaying your complete line of car interior protection products where your customers can see you putting them in their car • Convenient roll dispenser work station provides organized storage, helps save employee time and shows your customers you care about their car

FLOOR DISPENSER RACK

• Industry-leading dispenser system keeps products organized and within reach • Presents "We Care" image and promotes cleanliness • Retention straps prevent free-rolling and locking casters keep dispenser in place • Top tray holds paper floor mats and other service items while lower tray provides extra storage



399-60000



399-98893

Ascot No.	Mfg. No.	Description
399-60000	FK-P9943-76	Product Dispenser System (Includes Product)

Ascot No.	Mfg. No.	Description
399-98893	FB-P9833-89	Floor Dispenser Rack



DRAINS & PUMPS



BALCRANK PUMPLESS SELF-EVACUATING DRAINS - ROUGHNECK II

Self-evacuating pumpless drain; no pump required!

- Drain used motor oil or antifreeze into a 23-gallon steel reservoir, then connect to an air supply to evacuate used motor oil or antifreeze into any approved used bulk fluid storage container
- **DURABLE POWDER COAT FINISH:** Black for motor oil and green for antifreeze



322-41122

322-41123

Ascot No.	Mfg. No.	Capacity	Description
322-41122	4110-022	23-Gallon	Roughneck II Drain for Used Motor Oil
322-41123	4110-023	23-Gallon	Roughneck II Drain for Used Antifreeze

BALCRANK SPILLGUARD USED FLUID EVACUATION DRAINS

Spillguard series drains capture used fluid and allow for easy transfer to any bulk storage container using a cam-lock kit and evacuation pump system.

- **Standard 3" caster set mounted on wide-track dolly**
- **DURABLE POWDER COAT FINISH:** Black for motor oil or green for antifreeze
- **MADE IN THE USA**



322-41126

322-41127

Ascot No.	Mfg. No.	Capacity	Description
322-41126	4110-026	16-Gallon	Spillguard Used Motor Oil Drain
322-41127	4110-028	16-Gallon	Spillguard Used Antifreeze Drain

BALCRANK USED FLUID EVACUATION DRAINS

Premium series drains capture used fluid and allow for easy transfer to any bulk storage container using a cam-lock kit and evacuation pump system.

- **DURABLE POWDER COAT FINISH:** Black for motor oil or green for antifreeze
- **MADE IN THE USA**



322-41124

322-41125

Ascot No.	Mfg. No.	Capacity	Description
322-41124	4110-024	23-Gallon	Premium Duty Used Oil Drain
322-41125	4110-025	23-Gallon	Premium Duty Used Antifreeze Drain

BALCRANK ROLLING VACUUM EVACUATION DRAIN

Balcrank Used Fluid Evacuators are used for engine types that require top motor oil evacuation.

- **These units use vacuum to remove fluid from top port of engine or through the dip stick**
- *Optional clear Bowl attachment can be added or ordered to make measuring fluid removed faster and easier*



324-41456

Ascot No.	Mfg. No.	Capacity	Description
324-41456	4140-056	5.2-Gallon	Truck Drain for Antifreeze
324-41457	4140-057	5.2-Gallon	Truck Drain for Antifreeze w/ Clear Dome



DRAINS & PUMPS



18-GALLON POLYETHYLENE WASTE OIL DRAIN

- 18 gallon capacity
- Plastic drain container
- Comes with 16.5" funnel
- Extends from 40" to 73"
- Metal trolley comes with 4 casters and pull handle for safe and easier movement around the shop
- Oil can be drained either by pour gravity, integrated drain valve or using integrated bung hole rotary barrel pump (not included)
- SHIP WEIGHT: 24 lbs.

Ascot No.	Mfg. No.	Description
329-08874	8874	18-Gal Polyethylene Waste Oil Drain

18-GALLON LOW PROFILE WASTE OIL DRAIN

- Low profile drain height of 7.75"
- Large 18 gallon baffled tank reduces "slosh" during transport
- Large metal screen provides extra draining area and keeps out debris
- Convenient rotary hand pump for fast evacuation
- Long steel handle provides easy mobility to drain area
- SHIP WEIGHT: 47 lbs.

Ascot No.	Mfg. No.	Description
329-08878	8878	18-Gal Low Profile Waste Oil Drain



24-GALLON WASTE OIL DRAIN

- Large 24 gallon steel recovery tank with 6' drain hose
- Tank-mounted oil-level sight gauge and convenient tool tray
- Standard 15-3/4" drain funnel and wide 24" funnel adapter (shown) with drain tube that extends from 54" to 79"
- Pressure regulator
- Heavy duty wheels and casters
- SHIP WEIGHT: 82 lbs.

Ascot No.	Mfg. No.	Description
329-08890	8890	24-Gal Waste Oil Drain with Pressurized Evacuation

24-GALLON WASTE OIL DRAIN WITH PROBE KIT

- 18 gallon suction capacity
- 100 PSI shop air connected to vacuum gauge quickly creates suction
- Large 16" collection funnel (4-7/8 gallon capacity)
- Suction extraction at 1/2 gallon per minute
- 78" suction and drain hoses
- Pressurized evacuation of tank makes emptying easy
- 70.8" maximum height
- Six flexible evacuation probes and VW, Mercedes and BMW adapters
- Two air ports: 1 for pressure, 1 for vacuum
- SHIP WEIGHT: 93 lbs.

Ascot No.	Mfg. No.	Description
329-08895	8895	24-Gal Waste Oil Drain/Evacuator with Probe Kit



Balcrank

Fluid Dispensing Systems

HAND-OPERATED LEVER ACTION PUMP

• Suitable for dispensing lubricants and 100% anti-freeze • **PUMP INCLUDES:** 3/4" gooseneck spout, 3/4" telescoping suction tube, 1-1/2" and 2" combination bung-adapter



FITS 16-55 GAL. CONTAINERS

323-13001

Ascot No.	Mfg. No.	Description
323-13001	1300-001	Steel Hand Lever Pump

HAND-OPERATED ROTARY ACTION PUMP

• Suitable for dispensing lubricants and 100% anti-freeze • **PUMP INCLUDES:** 1" gooseneck spout, 1" suction tube, and 2" bung adapter



323-13022

FITS 16-55 GAL. CONTAINERS

Ascot No.	Mfg. No.	Description
323-13022	1300-022	Steel Hand Rotary Pump

ROLLING FLOOR TRUCK DRAIN

• Comes pre-assembled allowing for immediate use • Can be used for used motor oil or Antifreeze; decals provided for fluid identification • **FEATURES:** Two fixed wheels and 1 swivel caster, double baffles with upper screen and side splash lip • 3/4" or 1" Coupler kit sold separately



322-41203

Ascot No.	Mfg. No.	Capacity	Description
322-41203	4120-003	5.2-Gallon	Truck Drain for Antifreeze
322-41467	4140-067	—	Cam-Lock Coupler, Adapter and Valve Kit (3/4") for 4120-003 drain
322-41206	4120-006	26-Gallon	Truck Drain for Motor Oil
322-41461	4140-061	—	Cam-Lock Coupler, Adapter and Valve Kit (1") for 4120-003 drain

HAND-OPERATED LEVER PUMP

• Suitable for dispensing water based media, detergents, soaps, anti-freeze, windshield wash, and lubricants • **PUMP INCLUDES:** Built-In 2" bung adaptor with a lock nut incorporated in the pump body for pump positioning, telescoping suction tube and a 3/4" outlet equipped with an air vent cap, when loosened, breaks the siphon action of pump



FITS 16-55 GAL. CONTAINERS

323-13019

Ascot No.	Mfg. No.	Description
323-13019	1300-019	Poly Hand Lever Pump

HAND-OPERATED ROTARY PUMP

• Suitable for dispensing water based media, detergents, soaps, anti-freeze, windshield wash, lubricants • **PUMP INCLUDES:** 1" gooseneck spout, 1" telescoping suction tube, and 2" bung adapter



323-13133

FITS 16-55 GAL. CONTAINERS

Ascot No.	Mfg. No.	Description
323-13133	1300-0133	Poly Rotary Pump

LOW PROFILE TRUCK OIL DRAIN WITH LID

• Holds 60 quarts • Equipped with 4 rollers and a handle for transport and positioning under trucks • Cover and curved side design help keep fluids from spilling during movement • Convenient handles and pour spout facilitate fluid evacuation • Rolls under most cab over axles so oil can be changed without jacks or jack stands • **OVERALL HEIGHT: 7-1/2", WIDTH: 32-1/4", LENGTH: 49"**



322-19202

Ascot No.	Mfg. No.	Description
322-19202	19202	Low Profile Truck Oil Drain with Lid

DRAINS & PUMPS



TRANSMISSION DRAIN FUNNEL

- 22" by 23" heavy duty plastic lift drain funnel
- Extends the catch area of any lift drain
- Funnel catches any loose parts
- Prevents parts from falling through drain



322-17892

Ascot No.	Mfg. No.	Description
322-17892	17892	Transmission Drain Funnel

TRUCK & TRAILER WHEEL PAN

- Prevents oil mess during wheel repair
- The pan fits rims with 13 3/4" ID and larger
- Handle compartments hold hub nuts out of the oil
- Made of polypropylene for durability
- Will not warp if oil is warm
- **CAPACITY:** 88 ounces



322-19852

Ascot No.	Mfg. No.	Description
329-19852	19852	Truck & Trailer Wheel Pan



LOW BOY OIL DRAIN

- Rolls under trucks or buses to drain oil or antifreeze with ease
- Constructed of heavy duty polyethylene that will resist rust, dents, automotive fluids and other chemicals
- Gravity drain valve is recessed to protect it from damage and a wire screen in the pan prevents foreign matter from entering into the reservoir



322-24037

Ascot No.	Mfg. No.	Capacity	Description
322-24034	2400-34	17-Gallon	Low Boy Oil Drain
322-24037	2400-37	17-Gallon	Low Boy Oil Drain w/115V Evac



18-GALLON OIL LIFT DRAIN

- Translucent jug holds 18 gallons and will not warp with hot oil
- Rolls easily with four heavy-duty 2 1/2" wheels
- Metal tubes extend working area from 36-1/2" to 77"
- Drains from the bottom with a brass drain valve
- Large 15" funnel has a built in strainer to catch drain plugs



Ascot No.	Mfg. No.	Description
322-17432	17432	18-Gallon Oil Lift Drain



30-GALLON OIL DRAIN W/ CASTERS

- Four heavy duty 4" casters (2 fixed and 2 swivel)
- Heavy duty polyethylene construction
- 3/4" evacuation valve
- Rugged 18" black polyethylene funnel with a 2" non-corrosive adjustable tube
- Height adjusts from 55" to 78"
- Oval shape ideal for easy movement in a garage or shop environment
- Orange heavy duty polyethylene body is translucent for easy viewing of oil level
- **DIMENSIONS:** 18"D x 24"W x 55"H



329-24068

Ascot No.	Mfg. No.	Description
329-24068	2400-68	30-Gallon Oil Drain w/ Casters

OIL ACCESSORIES



OIL FILTER CRUSHER

- Crushes up to 4 filters at a time in the 9"x16" crush chamber
- 38,000 lbs of crushing force
- A door safety switch is standard for fleet maintenance facilities where EPA and recycling policies are in effect



Ascot No.	Mfg. No.	Description
322-00015	TC-15	Oil Filter Crusher

RADIATOR FILLERS

- Long curved spout, balanced shape and handle positions
- Weather resistant plastic
- 12-quart capacity



329-00505

Ascot No.	Mfg. No.	Description	Capacity
329-00505	6110-010	Black Plastic Radiator Filler	12 Quarts



6-QT. OIL DISPENSER

- Translucent white (see-through) polyethylene material enables the user to read the liquid level on the container
- Marked in both quarts and liters
- The flexible 8" pouring spout enables easy transfer of liquid
- The spout is white



329-19732

Ascot No.	Mfg. No.	Description
329-19732	19732	6-Quart Oil Dispenser

8-QT. OIL DISPENSER WITH LID & CAP

- 8-Quart Dispenser with a spout cap and lid to keep out dirt, dust and other contaminants
- Many large SUVs and trucks now require more oil — works great to transport bulk oil
- Translucent white polyethylene material enables the user to read the oil level on the container up to 8 quarts and is marked in both quarts and liters
- Flexible, removable 8" pouring spout enables easy transfer of liquid



329-19702

Ascot No.	Mfg. No.	Description
329-19702	19702	8-Quart Oil Dispenser with Lid & Cap



WATER/ANTI-FREEZE BIBB

- Durable, full volume dispense nozzle for water, windshield wash and antifreeze
- 1/4" NPT female inlet



329-18685

Ascot No.	Mfg. No.	Description
329-18685	3340-014	Water/Anti-Freeze Bib

SAFETY PRODUCTS



FACE SHIELDS

Ascot No.	Mfg. No.	Description
396-14955	14955	170-SB Crown and Window Kit
396-14200	14200	MAXVIEW™ Premium Face Shield - Clear Window
396-21000	21000	GPL500 Premium Goggle with Flip-Up Detachable Shield - Clear Lens, Anti-Fog

396-14955



396-14200



396-21000



NEW

SAFETY GLASSES-SMOKE LENS/CLEAR LENS

- 12 pcs. per inner box • 300 pcs. per case • Smoke lens • Anti-scratch & anti-fog coating • Lightweight, unisex protective eyewear • High wraparound coverage • Comfortable, contoured fit • Designed for indoor or outdoor use • Polycarbonate lenses absorb 99.9% UVA and UVB • ANSI Z87.1 CE EN 166

Ascot No.	Mfg. No.	Description
396-00902	SG-2 SMOKE	Safety Glasses-Smoke Lens
396-00901	SG-1 CLEAR	Safety Glasses-Clear Lens

396-00901



NEW

396-00902



SAFETY GLASSES

- **Lightweight, stylish, comfortable and very affordable** • High impact optically correct wrap style unitary PC lens offers superior coverage
- Soft, flexible temple tips & soft nose piece offers all day comfort
- Temples are curved inwards to ensure comfortable, slip-resistant fit
- Temple tips are curved outwards for gentle placement and removal • Meets ANSI Z87.1-2015 and tested to U.S. Military Standard MIL-PRF-31013
- Available in clear/black, amber/black and smoke/black styles

Ascot No.	Mfg. No.	Description
396-73601	S73601	Sellstrom XM330 Safety Glasses - Clear/Black
396-73611	S73611	Sellstrom XM330 Safety Glasses - Amber/Black
396-73621	S73621	Sellstrom XM330 Safety Glasses - Smoke/Black

396-73601



396-73611



396-73621



HEARING PROTECTION

Ascot No.	Mfg. No.	Description	Features
396-20773	20773	Jackson H70 Vibe Earmuffs - Orange	Highly padded ear cups for all day comfort, Dielectric, durable thermoplastic material retains shape and pressure, Great for environments such as lawn mowers, industrial work, traffic noise, etc.
396-23412	S23412	Sellstrom Disposable Ear Plugs - FOAM Bullet Shape, Corded, Hi-Viz Green (100 pairs per box)	Gently but quickly expand to fit ear canal, Soft non-irritating PU foam for max comfort, Independently tested/certified to NRR 32 (ANSI S3.19), CSA Class AL.
396-23421	S23421	Sellstrom Reusable Ear Plugs - Tapered, Corded, Blue/Hi-Viz Green (100 pairs per box)	Ensure optimum ear canal coverage, Firm push/pull post for easy insertion/removal, Reusable - Can be washed and reused, Non-allergenic polymer materials
396-23430	S23430	Sellstrom Banded Ear Plugs - Tapered, Hi-Viz Green (1 per bag)	Wear around the neck when not in use, Regular and intermittent applications - Easily removed, Band shape curves at the plug end to keep pods up and clean when not in use



396-20773



396-23430



396-23421



TEAR AWAY MESH SAFETY VESTS

• Meets visibility standards and requirements for medium risk traffic control and public safety workers, including school crossing guards, survey crews and more • COOLING COMFORT - Polyester mesh is breathable, durable and keeps you cool on the job • HI-VIS - Includes StarTech reflective tape for excellent visibility • Features 5 point tear-away and D-ring access slot



396-30561

396-30551

Ascot No.	Mfg. No.	Description
396-30551	V1030550U-S/M	Safety Vest - Hi-Vis Orange, Size S/M
396-30552	V1030550U-L/XL	Safety Vest - Hi-Vis Orange, Size L/XL
396-30553	V1030550U-2/3XL	Safety Vest - Hi-Vis Orange, Size 2XL/3XL
396-30554	V1030550U-4/5XL	Safety Vest - Hi-Vis Orange, Size 4XL/5XL
396-30561	V1030560U-S/M	Safety Vest - Hi-Vis Yel/Green, Size S/M
396-30562	V1030560U-L/XL	Safety Vest - Hi-Vis Yel/Green, Size L/XL
396-30563	V1030560U-2/3XL	Safety Vest - Hi-Vis Yel/Green, Size 2XL/3XL
396-30564	V1030560U-4/5XL	Safety Vest - Hi-Vis Yel/Green, Size 4XL/5XL



DRIVEWAY SIGNAL AND HOSE

• Know when you have a customer at the pumps with this 6" diameter driveway signal bell • Completely self-contained unit makes installation easy • Each signal is manufactured to give you a signal that will perform under prolonged use



392-00805

Ascot No.	Mfg. No.	Description
392-00805	805	Driveway Signal - 110V 6" Dia. Bell
392-00838	838	50' Coil of Driveway Signal Hose
392-00839	839	300' Coil of Driveway Signal Hose

KNEE PADS - ULTRA FLEX III

• Articulating hinge ensures proper placement all day • Soft elastic and wide straps are well placed and above the knee - No velcro • Strong & flexible plastic outer shells • Pads offer 5/8" closed cell foam pad. Sweat will not penetrate • Built for years of hard work and heavy use



396-96110

Ascot No.	Mfg. No.	Description
396-96110	S96110	KneePro Ultra Flex III Knee Pads - Grey/Orange

EYE WASH STATIONS

• The ideal first response solution when continuous water supply is unavailable • Quickly flushes contaminants from eyes using a sterile, buffered & preserved solution • Can be wall-mounted or placed on flat surfaces • Highly visible green backboard • Available in 6 gallon personal station or 32 oz. bottle station



396-90333

396-90306

Ascot No.	Mfg. No.	Description
396-90306	S90306	Sellstrom 6-Gallon Grav-It Portable Eyewash Station
396-90333	S90333	Sellstrom 32 oz. Double Rapid-Clear Eyewash Bottle Station



DOT CONSPICUITY TAPE

• Meets all Federal and State certifications • Micro prismatic technology • Thin and flexible • 10-year durability



396-62150

Ascot No.	Mfg. No.	Description
396-62150	CT6R6W2150	2" x 150' (6" Red, 6" Silver)
396-72182	CT11R7W2X18	2" x 18" Strip (11" Red, 7" Silver)
396-72150	CT11R7W2150	2" x 150' (11" Red, 7" Silver)
396-82150	CTR2150	2" x 150' Solid Red
396-92150	CTW 2150	2" x 150' Solid Silver
396-93150	CTY2150	2" x 150' Solid Yellow

WHEEL CHOCKS



RUBBER WHEEL CHOCK

- Durable rubber construction
- Features an eye bolt for chain or rope attachment
- Ribbed pyramid design
- Either side of wheel chock can be positioned against the tire
- Sold individually
- **WEIGHT:** 10 lb. (4.5kg)

396-15300



Ascot No.	Mfg. No.	Description
396-15300	15300	Rubber Wheel Chock

OTR WHEEL CHOCK

- **DIMENSIONS:** 12" x 10" x 12"
- Designed for heavy duty truck and mining equipment
- 20" rope attached for convenience
- **NET WEIGHT:** 27.5 lb.

396-00102



Ascot No.	Mfg. No.	Description
396-00102	TS102	OTR Wheel Chock

POLYURETHANE WHEEL CHOCKS

- Rugged yet lightweight, weather-resistant Polyurethane wheel chocks
- Safety yellow for high-visibility and meets OSHA/MSHA standards
- Built-in carrying handle & holes for installation of ropes, chains and/or mounting brackets



396-12594

396-12590

396-12593

396-12596



Ascot No.	Mfg. No.	Tire Size	Size (L x W x H)	Weight
396-12590	12590	Up to 27 in.	8" x 7" x 6"	2
396-12593	12593	46" to 65"	12.125" x 15.25" x 10.75"	16
396-12594	12594	Up to 65 in.	16.25" x 14.5" x 13.25"	20
396-12596	12596	Up to 165 in.	24.5" x 14.25" x 16"	34

URETHANE WHEEL CHOCKS

- **SOLID LIGHTWEIGHT CONSTRUCTION** • High impact urethane material
- Non-conductive, no threat to puncture the tire
- Durable, lightweight and easy to use
- Extensively field tested



396-15336

396-15337

396-15338

396-15339

396-15342



396-15353

Ascot No.	Mfg. No.	Tire Size	Dimensions (LxWxH)	Weight
396-15336	15336	35" to 55" (90 cm to 140 cm)	13.3" x 8.6" x 7.8" (34 cm x 22 cm x 20 cm)	7.7 lb. (3.5 kg)
396-15337	15337	47" to 86" (120 cm to 220 cm)	18" x 12" x 9" (47.5 cm x 30.5 cm x 22.5 cm)	13 lb. (6 kg)
396-15338	15338	70" to 118" (180 cm to 300 cm)	22.5" x 13" x 14" (57 cm x 34 cm x 35.5 cm)	19.8 lb. (9 kg)
396-15339	15339	110" to 165" (280 cm to 420 cm)	26.7" x 13" x 14" (68 cm x 33.7 cm x 35.5 cm)	30.86 lb. (14 kg)
396-15342	15342	86" to 137.8" (220 cm to 350 cm)	24" x 13.5" x 12" (62.1 cm x 34.3 cm x 32.3 cm)	24.3 lb. (11 kg)
396-15353	15353	47" to 70" (120 cm to 180 cm)	13.38" x 9.84" x 7.8" (34 cm x 25 cm x 22.5 cm)	13.66 lb. (6.2 kg)

NEW

INDUCTION HEATERS



INDUCTION HEATERS & ACCESSORIES

The professional's choice hand held flameless torch. The flameless solution for releasing corroded or frozen hardware and other metallic components from corrosion and threadlock compounds – all without the collateral damage normally associated with torches. Heats nuts red hot in seconds! Available in a variety of models for all applications.

319-00787
Mini Ductor
Venom HP



319-00777
Mini Ductor
Venom



319-00555
Mini Ductor
Attachment Kit



319-20311
Inductor
Glass Blaster Kit



319-02011
Inductor Max HS

Ascot No.	Mfg. No.	Description	Kit Contains
319-00555	U-555	Attachment Kit for Mini Ductor	<ul style="list-style-type: none"> • 3 Basic Coils: (MD99-601) 7/8" Pre-Formed Coil, (MD99-602) U-Form Coil, (MD99-603) 41" Bearing Buddy Coil
319-00777	MDV-777	Mini Ductor® Venom® - 110V	<ul style="list-style-type: none"> • 3 Basic Coils: (1) 7/8" Pre-Formed Coil, (1) 23" U-Form Coil, (1) 41" Bearing Buddy Coil • Rugged Plastic Carrying Case • Operator Manual • 2-year Manufacturer's Warranty
319-00787	MDV-787	Mini Ductor® Venom® HP - 120V	<ul style="list-style-type: none"> • 3 Basic Coils: (1) 7/8" Pre-Formed Coil, (1) 23" U-Form Coil, (1) 41" Bearing Buddy Coil • Rugged Plastic Carrying Case • Operator Manual • 2-year Manufacturer's Warranty
319-02011	IM-IND2011	Inductor Max HS	<ul style="list-style-type: none"> • U-Series Concentrator® (U-411): instantly heats nuts, bolts and all types of hardware red-hot in seconds and removes body caulking, seam sealers and hail dents • U-Series Glass Blaster® (U-311): removes bonded glass, SMC panels, metal bond adhesives and spray-on bedliners • U-Series Fast-Off® Pad (U-211): removes stripes, vinyl graphics, body side moldings, sound pads, vapor barriers, stress relieving sheet metal repairs and more • Inductor Max Power Supply (MXP1) • (2) L-wedges (L-0810A) • Instruction manual • 1-year warranty
319-20311	GB-20311	Inductor Glass Blaster Kit	<ul style="list-style-type: none"> • Carrying case • (2) L-wedges (L-0810A) • Instruction manual • 1-year warranty
319-99660	MM99-660	Essential Coil Kit for Mini Ductor®	<ul style="list-style-type: none"> • Two 7/8" pre-formed coils (MD99-601: 5"L x 1.25"W) • Two 3/4" pre-formed coils (MD99-611: 4.5"L x 1.25"W) • One 7/8" long pre-formed coil (MD99-605: 9.5"L x 1.25"W) • One 1" pre-formed coil (MD99-610: 8.25"L x 1.75"W) • One 7/8" long pre-formed coil (LCK) (MD99-621: 13.25"L x 1.25"W) • One 1" long pre-formed coil (MD99-622: 13.25"L x 1.75"W)
319-99675	MM99-675	Long Coil Kit for Mini Ductor®	<ul style="list-style-type: none"> • One 3/4" pre-formed coil (Part #MD99-620: 13.25"L x 1.25"W) • Two 7/8" long pre-formed coils (LCK) (MD99-621: 13.25"L x 1.25"W) • Two 1" long pre-formed coils (MD99-622: 13.25"L x 1.75"W) • One 1 1/4" pre-formed coil (Part #MD99-623: 13.25"L x 2"W) • One 1 1/2" pre-formed coil (Part #MD99-624: 13.25"L x 2"W) • One 1 3/4" pre-formed coil (Part #MD99-625: 13.25"L x 2.25"W)



INDUCTION HEATERS



BEARING BUDDY PACK FOR MINI DUCTOR

Kit Contents:

- (1) 41" Bearing Buddy™Coil (MD99-603)
- (1) 96" Bearing Buddy™Coil (MD99-XBB96)
- (1) 6" x 12" Heat Resistant Insulator (MD99-612)
- (1) Compact Storage Tube

Ascot No.	Mfg. No.	Description
319-99643	MD99-643	Bearing Buddy Pack for Mini Ductor®



THIN WALL COIL PACK FOR MINI DUCTOR

Kit Contents:

- (1) 3/4" Thin Wall Coil (MD99-629)
- (1) 13/16" Thin Wall Coil (MD99-631)
- (1) 7/8" Thin Wall Coil (MD99-632)
- (1) 1" Thin Wall Coil (MD99-635)
- (1) Compact Storage Tube

Ascot No.	Mfg. No.	Description
319-99644	MD99-644	Thin Wall Coil Pack for Mini Ductor®



THIN WALL COIL PACK FOR MINI DUCTOR

Kit Contents:

- One 1 3/4" pre-formed coil (MD99-607: 8.75"L x 2.25"W)
- One 1 1/2" pre-formed coil (MD99-608: 8.5"L x 2"W)
- One 1 1/4" pre-formed coil (MD99-609: 8.25"L x 2"W)
- One 1" pre-formed coil (MD99-610: 8.25"L x 1.75"W)
- Two 7/8" pre-formed coils (MD99-601: 5"L x 1.25"W)
- One 3/4" pre-formed coil (MD99-611: 4.5"L x 1.25"W)
- One 7/8" long pre-formed coil (MD99-605: 9.5"L x 1.25"W)

Ascot No.	Mfg. No.	Description
319-99650	MD99-650	Standard Coil Kit for Mini Ductor®



MINI-DUCTOR® REPLACEMENT PARTS

Ascot No.	Mfg. No.	Description
319-99601	MD99-601	Mini-Ductor® 7/8" Pre-Formed Coil
319-99611	MD99-611	Mini-Ductor® 3/4" Pre-Formed Coil
319-99602	MD99-602	Mini-Ductor® 23" U-Form Coil



MECHANIC'S GLOVES



NITRILE GLOVES

- Powder-free disposable nitrile gloves • 4.5 mil
- Suitable for automotive and industrial applications
- QUANTITY: 100 per box, 10 boxes per case



396-00802

Ascot No.	Mfg. No.	Description
396-00802	BLK-M	Black Nitrile Gloves (M)
396-00803	BLK-L	Black Nitrile Gloves (L)
396-00804	BLK-XL	Black Nitrile Gloves (XL)
396-00805	BLK-XXL	Black Nitrile Gloves (XXL)



RPG NITRILE MICRO-DIAMOND GLOVES

- **Textured finish** • For industrial and automotive applications
- Powder-free • **THICKNESS:** 6 mil Not made from natural rubber latex • **QUANTITY:** 100 per box, 10 boxes per case



396-00301

396-00401

Ascot No.	Mfg. No.	Description
396-00301	32806BK240R2	Micro Diamond Black Nitrile Glove (Small)
396-00302	32806BK240R3	Micro Diamond Black Nitrile Glove (Medium)
396-00303	32806BK240R4	Micro Diamond Black Nitrile Glove (Large)
396-00304	32806BK240R5	Micro Diamond Black Nitrile Glove (XL)
396-00305	32806BK240R6	Micro Diamond Black Nitrile Glove (XXL)
396-00401	32806OR240R2	Micro Diamond Orange Nitrile Glove (Small)
396-00402	32806OR240R3	Micro Diamond Orange Nitrile Glove (Medium)
396-00403	32806OR240R4	Micro Diamond Orange Nitrile Glove (Large)
396-00404	32806OR240R5	Micro Diamond Orange Nitrile Glove (XL)
396-00405	32806OR240R6	Micro Diamond Orange Nitrile Glove (XXL)



RPG MECHANIC'S GLOVES

- **Black synthetic leather palm with small patches**
- Features blue spandex on back, neoprene on knuckle, 4cm wide elastic, hook & loop



396-10011

Ascot No.	Description
396-10011	RPG Mechanic's Gloves

HIGH VISIBILITY MECHANICS GLOVES

- **Grey synthetic leather with silicon printing on palm**
- High visibility Spandex back with back of the hand protection • Impact protection • Hook and loop • One size fits most



396-14202

396-14201

Ascot No.	Mfg. No.	Description
396-14201	FGM-420	Green/Black Mechanics Gloves - Pair
396-14202	FOM-420	Orange/Black Mechanics Gloves - Pair

MECHANIC'S GLOVES



WORK GLOVES

Gaither's Work Gloves are designed to provide the best possible protection while still delivering the grip and flexibility required for performing intricate and complex tasks.

- Perfect for tire maintenance and general shop use
- Machine washable
- Impact protection
- Double Stitched
- Industrial grade hook and loop
- Slip-free silicone grip



Ascot No.	Mfg. No.	Description
396-49101	G49110S	Small Work Gloves
396-49102	G49110M	Medium Work Gloves
396-49103	G49110L	Large Work Gloves
396-49104	G49110XL	Xtra Large Work Gloves

COLORED LEATHER DOUBLE PALM WORK GLOVES

- Split leather double palm
- Colored fabric on the back of the hand
- Half fleece lining
- 12 pairs per package



396-55221

396-55222

Ascot No.	Mfg. No.	Description
396-55221	AB-R	Red Leather Double Palm Work Gloves
396-55222	AB-G	Green Leather Double Palm Work Gloves

MISCELLANEOUS HAND PROTECTIVE GLOVES



396-06780



396-40317



396-55220

Ascot No.	Description
396-06780	Wet Grip Neoprene Glove. Protects Against Acids, Caustics, Oils, Greases And Many Solvents. 5-Piece Flannel Liner
396-40317	Power Grip with Latex Premium Grip
396-55220	Leather Palm Glove with Safety Cuff, Elastic

HIGH VISIBILITY DUAL COLOR LEATHER DOUBLE PALM GLOVES

- Split leather double palm
- High visibility green and orange colors
- Half fleece lining
- 12 pairs per package



396-55223

Ascot No.	Mfg. No.	Description
396-55223	AB-HVDC	High Visibility Dual Color Leather Double Palm Gloves

HEAVY DUTY DIAGNOSTIC TOOLS



ATS100 CV TURN ASSIST RADAR SYSTEM

- Radar-based turn-assist system for Commercial vehicles
- Active warning with OE-level radar technology
- Active warning in low speed situation, turn assist
- Active warning for vehicle in high speed situation, lane change assist
- Plug and Play installation, requires power supply
- Includes radar sensor and needed installation hardware
- Includes display unit with audible warnings
- 120 feet (37 Meter) Warning distance
- 180 Degree Field of View (FOV) coverage



356-00100

Ascot No.	Mfg. No.	Description
356-00100	ATS100	ATS100 CV Turn Assist Radar System

MAXISYS ULTRA ADVANCED DIAGNOSTIC TABLET

- Large 12.9" Touchscreen (2732 x 2048) / Android 7.0
- 2.3GHz + 1.7GHz Octa-core Processor / 256GB Memory
- Advanced VCI 5-In-1 Device: VCI, Oscilloscope, Multimeter, Waveform Generator, CAN BUS Check
- Oscilloscope Preset Guided & Component Tests / Waveform Library
- New VCI Protocols: D-PDU, DoIP/CAN FD, Mega CAN
- Split Screen Multi-Application Function / Dual Wi-Fi Connection
- Topology Module Mapping: Color Coded All System Status Screen (on supported vehicles)
- Relevant Cases: DTC Troubleshooting / Repair Tips Video Library
- Repair Assist: Guided Procedures with DTC Analysis & Fault Code Solutions
- Code-Related Technical Service Bulletins (on select vehicles) / License Plate Reader
- ScanVIN: Barcode or Text Recognition with Camera
- Secure Gateway Access: Authorized FCA SGM Access with AutoAuth Account
- Includes Docking Station, Cables, Scope Connectors, Carrying Case, 1YR Warranty & Software Subscription
- Enhanced Diagnostic Reports: PreSCAN & PostSCAN
- 18000mAh - 8hrs Continuous Use / 16MP Rear Camera & 5MP Front Camera



351-01326

Ascot No.	Mfg. No.	Description
351-01326	MSULTRA	MAXISYS Ultra Advanced Diagnostic Tablet

HEAVY DUTY DIAGNOSTIC TOOLS



MAXISYS MS919 DIAGNOSTIC TABLET

- 9.7" Touchscreen (1536 x 2048) / Android 7.0
- 2.3GHz+1.7GHz Octa-core Processor / 128GB Memory
- Advanced VCI 5-In-1 Device: VCI, Oscilloscope, Multimeter, Waveform Generator, CAN BUS Check
- Oscilloscope Preset Guided & Component Tests / Waveform Library
- New VCI Protocols: D-PDU, DoIP/CAN FD, Mega CAN
- Topology Module Mapping: Color Coded All System Status Screen (on supported vehicles)
- Relevant Cases: DTC Troubleshooting / Repair Tips
- Repair Assist: Guided Procedures with DTC Analysis & Fault Code Solutions
- Code-Related Technical Service Bulletins (on select vehicles) / License Plate Reader
- ScanVIN: Barcode or Text Recognition with Camera
- Secure Gateway Access: Authorized FCA SGM Access with AutoAuth Account
- Includes Cables, Scope Connectors, Carrying Case, 1YR Warranty & Software Subscription
- Enhanced Diagnostic Reports: PreSCAN & PostSCAN
- Dual Wi-Fi Connection
- 15000mAh - 8hrs Continuous Use / 16MP Rear Camera & 5MP Front Camera



351-00919

Ascot No.	Mfg. No.	Description
351-00919	MS919	MAXISYS MS919 Diagnostic Tablet

MAXISYS MS909 DIAGNOSTIC TABLET

- 9.7" Touchscreen (1536 x 2048) / Android 7.0
- 2.3GHz+1.7GHz Octa-core Processor / 128GB Memory
- New VCI Protocols: D-PDU, DoIP/CAN FD, Mega CAN
- Topology Module Mapping: Color Coded All System Status Screen (on supported vehicles)
- Relevant Cases: DTC Troubleshooting / Repair Tips
- Repair Assist: Guided Procedures with DTC Analysis & Fault Code Solutions
- Code-Related Technical Service Bulletins (on select vehicles) / License Plate Reader
- ScanVIN: Barcode or Text Recognition with Camera
- Secure Gateway Access: Authorized FCA SGM Access with AutoAuth Account
- Includes Cables, MaxiFlash VCI, Carrying Case, 1YR Warranty & Software Subscription
- Enhanced Diagnostic Reports: PreSCAN & PostSCAN
- 15000mAh - 8hrs Continuous Use / 16MP Rear Camera & 5MP Front Camera



351-00909

Ascot No.	Mfg. No.	Description
351-00909	MS909	MAXISYS MS909 Diagnostic Tablet

TRUCK SHOP EQUIPMENT



HEAVY DUTY CODE READER KIT

- The perfect tool for technicians that need a fast "Toolbox Tool" to read and clear heavy-duty DTC's, heavy-duty shops that need a second tool in the shop and for their mobile repair trucks, or aftermarket general repair shops that are looking for a cost effective solution for Heavy-Duty Standard coverage

KIT INCLUDES:

- 3 Year Warranty
- HD Reader tool
- 9 Pin Deutsch Cable
- 6 Pin Deutsch Cable
- Operations Manual
- Soft Nylon Carrying Case



351-03418

Ascot No.	Mfg. No.	Description
351-03418	3418	Heavy Duty Code Reader Kit

NEXIQ IQ HD SCAN TOOL

- Pro-Link iQ is designed to help diagnose engine, brake, and transmission failures
- This easy-to-use, advanced tool is engineered to support today's commercial vehicles as well as the more complex vehicles of tomorrow
- Using clear menus and message screens, the Pro-Link iQ guides technicians through the most complicated vehicle tests



351-03110

Ascot No.	Mfg. No.	Description
351-03110	3110	NEXIQ IQ HD Scan Tool

OTC DEF REFRACTOMETER

EPA regulations require all diesel engines manufactured on or after January 1, 2010 to meet lowered NOx emissions standards. Most heavy duty engine (Class 7-8 trucks) manufacturers, have chosen to utilize SCR. This Includes Detroit Diesel (DD13, DD15, and DD16 models), Cummins (ISX line), PACCAR, and Volvo/Mack. SCR-equipped engines require the periodic addition of Diesel Exhaust Fluid (DEF, a urea solution) to enable the process. DEF is available in a bottle from most truck stops, and some have installed bulk DEF dispensers near the Diesel Fuel pumps. However, to ensure the proper operation of the SCR system, operators must ensure the DEF in their vehicle consists of a 32.5% Urea / Water solution.

- The OTC 5025 makes this a simple and quick process for an operator or technician.
- **SCALE:** 0.5% line graduations, 32.5% Indicated, Scale 15-40% Waterline & 20 Deg. C



KIT INCLUDES:

- Refractometer
- Dropper
- Lens wipe cloth
- Instructions and quick guide
- Screwdriver and case



335-05025

Ascot No.	Mfg. No.	Description
335-05025	5025	OTC DEF Refractometer



TRUCK SHOP EQUIPMENT



PORTABLE

335-05280

DIESEL PARTICULATE FILTER (DPF) CLEANER

The Diesel Particulate Filter (DPF) Cleaner was designed with shop service in mind.

- The cleaning process allows the DPF to be cleaned as part of a general maintenance schedule at the service location with minimal time away from the vehicle
- Its portability allows the unit to be placed as close to the vehicle as possible and to be stored wherever needed in the service facility

Ascot No.	Mfg. No.	Description
335-05280	5280	Diesel Particulate Filter (DPF) Cleaner

OTC PORTABLE DIESEL PARTICULATE FILTER CLEANER

The Diesel Particulate Filter (DPF) Cleaner was designed with shop service in mind. Its portability allows the unit to be placed as close to the vehicle as possible and to be stored wherever needed in the service facility. The advent of the 2010 Tier 4 cleaning requirements created the need for a lighter, more portable cleaning system which can be taken into the field to clean filters at the point of service.

- **LIGHTWEIGHT AND HIGHLY PORTABLE:** ideal cleaning system for use in the shop or on a service truck
- **FLEXIBILITY:** Clean DPFs from 6" to 15.5" in diameter using shop or compressed air of at least 100 PSI and 20 CFM sustained airflow
- **FULLY AUTOMATED OPERATION:** Once started, the cleaning process can be completed with minimal operator oversight, freeing up the technician to simultaneously do other work in the shop
- **FOCUSED AIR JET TECHNOLOGY™:** Concentrates a precise high pressure stream of air directly into every cell
- **EASY MAINTENANCE:** Contains no internal filters that require user maintenance
- **RUGGED DESIGN:** Provides maximum durability

HIGHLY PORTABLE

FOCUSED AIR JET



335-05286

Ascot No.	Mfg. No.	Description
335-05286	5286	OTC Portable Diesel Particulate Filter Cleaner



SUPER MUTT TRAILER TESTER

The Super MUTT® Trailer Tester is a Mobile Diagnostic Trailer Tester that places a load on the trailer's electrical circuits to identify wiring problems while providing remote control operation over both air brakes and lights.

Built to facilitate a one-man testing operation, the Super MUTT® reduces guesswork and inspection time to prevent failures that lead to expensive road calls and citations.

The remote control allows for repetitive air brake actuation at each axle to reveal developing problems often missed by normal testing procedures.

AIR BRAKE TESTING

- Performs leak down test on service and emergency lines
- Observe slacker adjustment in real time
- Activates air brakes by remote control

REMOTE CONTROL

- One-man testing
- Real-time servo on/off engagement
- Programs multiple remotes; 100 ft. range

ELECTRICAL TESTING

- Pulsar® mode, cross, open, overloaded and shorted circuit indication
- Amperage readout; audible and visible alerts
- 7 way cable testing
- Access ABS blink codes
- Activates lights by remote control

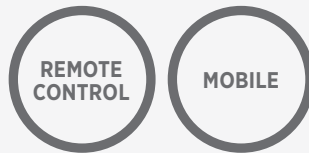

Ascot No.	Mfg. No.	Description
356-09008	9008-SE	Super MUTT Trailer Tester



WHEEL BEARING LOCKNUT SOCKETS / BOARD



- Wheel bearing locknuts are easy to remove or install with these specially designed sockets
- **HEAVY DUTY:** They're made of high-strength steel and resist rounding out
- **INCLUDED:** 12 wheel bearing locknut sockets with tool board.
- *NOTE: Sockets are designed for use with 3/4" square-drive manual tools only. Impact tool use voids sockets' warranty*

PARTS INCLUDED:

Mfg. No.	Description
1909	Locknut socket (3-1/4" 8 pt.)
1910	Locknut socket (3-1/2" hex)
1913	Locknut socket (3-7/8" 8 pt.)
1914	Locknut socket (4" hex)
1915	Locknut socket (4-1/8" hex)
1921	Locknut socket (2-1/2" hex)
1922	Locknut socket (2-5/8" hex)
1923	Locknut socket (2-3/4" hex)
1928	Locknut socket (2-9/16" hex rounded)
1932	Locknut socket (2-7/8" hex)



314-09852

Ascot No.	Mfg. No.	Description
314-09852	9852	Wheel Bearing Locknut Sockets / Board

UNIVERSAL BEARING CUP INSTALLER

- This handy, adjustable tool is designed to install wheel-bearing cups in a wide range of heavy-duty axles. Simply adjust and lock the jaws to the cup I.D., slip on the new cup, set it in the bore, and drive it in with a hammer
- The tool helps eliminate the damage caused by makeshift methods
- Works on axles from 11,000 to 50,000 lb. capacity.
- Adjusts to fit 3-5/8" to 6-1/2" O.D. bearing cups, which adds up to as many as 30 individual drivers



314-07180

Ascot No.	Mfg. No.	Description
314-07180	7180	Universal Bearing Cup Installer

RECOVERY, RECYCLING & REFRIGERANT SYSTEMS



COOL-TECH 34788NI RECOVERY/RECYCLING SYSTEM

- Fully automatic operation
- 98.5% recovery • R134a
- **IMPROVED CHARGE PERFORMANCE:** Exceeds SAE requirements • Graphical display • **EXPANDABLE:** Capable of additional feature and function add-ons (printer, wireless, refrigerant ID)
- Automatic Internal tank fill



361-34788

FX3030 DUAL REFRIGERANT MANAGEMENT SYSTEM

- Certified to meet SAE J3030 for use in R134a and R1234yf systems
- Includes a Refrigerant Identifier

DUAL UNIT HANDLING BOTH REFRIGERANT



Ascot No.	Mfg. No.	Description	Shipping Wt.
361-34788	34788NI	Recovery/Recycling System	235 lb.
361-34789	34788NI-H	Hybrid Recovery/Recycling System	222 lb.



ARCTICPRO ACX2280 R1234YF REFRIGERANT HANDLING SYSTEM

- Fully automatic • 2-year warranty parts and labor • 7" capacitive color touch screen • 1.8 CFM dual-stage vacuum pump • 30 lb. DOT refrigerant tank • Hybrid capable • Integrated Refrigerant Identifier • WIFI & Bluetooth • Remote diagnostics • Customer report • Wireless Printing
- **PHONE APP FOR MIRRORING:** iOS & Android-capable database



361-02280



361-03030

Ascot No.	Mfg. No.	Description
361-02280	ACX2280	ArcticPro ACX2280 R1234YF Refrigerant Handling System

Ascot No.	Mfg. No.	Description
361-03030	FX3030	FX3030 Refrigerant Management System

MAHLE

FLUID EXCHANGERS & FLUSHERS



FLUIDPRO™ ATX AUTOMATIC TRANSMISSION FLUID EXCHANGERS

372-00103



- **ADAPTABLE:** 'Dipstick' or 'Cooler' mode selector, start engine indicator (ATX-3 only)
- **ELECTRONIC DIODE ILLUMINATED KEYPAD:** Fluid flow direction indicator verifies correct hook-up
- **TRANSMISSION DIAGNOSTIC PRESSURE GAUGE:** For a more effective exchange process
- **NEW AND USED FLUID SIGHT GLASSES:** Improve service accuracy
- **AUTOMATIC FLUID LEVEL ADJUSTMENT:** +/- 1/2 quarts
- **DIGITAL WEIGHT SCALE:** Technology for accurate fluid exchange
- **PATENTED BYPASS CIRCUIT:** Increased safety for vehicle protection
- **FAST:** Full exchange service times of 2 to 5 minutes and 8 to 14 minutes in 'Dipstick' mode

Ascot No.	Mfg. No.	Description
372-00103	ATX-3+ Boost	Fully Automatic Transmission Fluid Exchanger w/ Dipstick Tube Exchange



368-00202

Ascot No.	Mfg. No.	Description
368-00202	PSX-3	Power Steering Fluid Exchanger

FLUIDPRO BFX-3 BRAKE FLUSH SYSTEM

- **VERSATILE:** Compatible with both ABS & non-ABS brake systems for increased utility
- **PISTOL WAND:** Provides convenience and accurate fill
- **AUTOMATED PUSH/PULL PROCESS:** Allows technicians to multi-task
- **EASY:** Hook-up with three-step process for simple servicing
- **FAST:** Complete service in less than 10 minutes for improved customer satisfaction
- **PRESSURE GAUGE:** Assist in brake system diagnosis
- **LCD DISPLAY:** Indicates when new fluid cylinder is empty and used fluid tank is full
- **ADAPTABLE:** Universal adapters designed to fit many makes and models of vehicles, enhancing service offerings



368-00201

Ascot No.	Mfg. No.	Description
368-00201	BFX-3	Brake Flush System

FLUIDPRO PSX-3 POWER STEERING FLUID EXCHANGER

- **VERSATILE:** Multiple power steering fluid capability for increased compatibility
- **AUTOMATIC OPERATION:** Boosts technician efficiency
- **DUAL-PROCESS HOSES:** Provides visual insight to new versus used fluid
- **DUAL DIAPHRAGM-TYPE PUMPS:** Yields service times of 5-15 minutes
- **EFFECTIVE:** Equipped with 1 GAL new and 1 GAL used fluid tanks for complete servicing
- **COMPACT CART:** Designed to occupy less floor space
- **CONVENIENT:** Also available with ATX+Boost mount for providing automatic transmission fluid and power steering fluid exchange services at the same time

ACCESSORIES



DEF DRUM PACKAGES



- Heavy-duty cart easily holds and rolls up to 55 gallon drum
- 110 VAC Stainless Steel Electric Diaphragm pump • **LARGE SEMI-PNEUMATIC TIRES:** Allows for easy maneuvering of cart • Large non-marking rear caster with built in brake for safe and secure dispensing • **INCLUDES:** 3' suction hose and 12' dispense hose • Battery powered electronic meter with display • **Dispense nozzle:** Stainless steel automatic shut-off nozzle • *Coupler system to drum is sold separately*



329-21250

329-21251

Ascot No.	Mfg. No.	Description
329-21250	1210-049P	Portable drum package w/ side mount, 110V electric diaphragm pump, metered auto stainless steel nozzle
329-21251	1210-049	Tote Package w/ side mount, 110V electric diaphragm pump, metered auto stainless steel nozzle

REFRIGERANT CHARGING SCALE

- Touch Key controls • **THREE DISPLAY MODES:** lb./oz., decimal lb., kilograms • **VERY HIGH RESOLUTION:** 0.1 oz./0.005 lb./2 grams • Extreme accuracy • 110 lb./50 kg capacity
- Auto zero • Compact design, completely portable • *Can be used with all refrigerants* • Removable control box with prop stand/hanging hook • *Compatible with TIF 9020 for automatic capability*



361-09010

Ascot No.	Mfg. No.	Description
361-09010	TIF 9010A	Refrigerant Charging Scale

INFRARED THERMOMETER PRO

- **SoC (System-on-a-Chip) Technology:** Complete IR design incorporated on a single chip, creating compact and lightweight design • Innovative optical lens: High accuracy measurements over wide temperature ranges. 10:1 distance to spot (D:S) ratios available
- Laser pointer: Simply point at desired target and press the trigger for temperature reading
- High and low pass filters with audible alarms for out of range measurements • Temperature modes: Maximum (MAX) • Visual low battery indicators; requires two AAA batteries



369-07610

Ascot No.	Mfg. No.	Description
369-07610	TIF7610	Infrared Thermometer PRO

R134A MANIFOLD HOSE KIT

- R12/R134G gauges, PSI and °F Temp • ½" ACME bottom ports • Rear R134A and ½" ACME fittings for holding hoses • 90° manual couplers
- 72" R134A Hose Set (1/2" ACME x 14mm) • Brass manifold with easy-to-grip handles



366-45111

Ascot No.	Mfg. No.	Description
366-45111	45111	134A Manifold Gauge Set with 72" Hose and Couplers

CHARGED AIR COOLER TESTER

- The easy way to find air leaks in the charged air cooler systems used on class 7 & 8 truck engines • The tester features a large 2-1/2", 0-60 PSI pressure gauge, regulator and relief valve, and two safety cables • It also has quick disconnect air fittings that attach to a 3", 3-1/2", or 4" cooler hose



366-05039

Ascot No.	Mfg. No.	Description
366-05039	5039	Charged Air Cooler Tester

CEMENTS, SEALANTS & PATCHES



PREMA^{HC}

INDUSTRY STANDARD TRUCK KIT

- Conveniently packaged industry standard repair kits



518-29150

Ascot No.	Mfg. No.	Description
518-29150	2009150	Industry Standard Truck Kit

PARTS INCLUDED

- PC-2 Combi Repair Units (15)
- PC-3 Combi Repair Units (10)
- PUS-3 Universal Square Patch 3 (20)
- PUS-4 Universal Square Patch 4 (20)
- PCS-2 Stem w/Guide Wire (20)
- PCS-3 Stem w/Guide Wire (20)
- PFC-8 Ultra Fast Dry (8oz)
- PPC-16 Prebuff Cleaner Spray (16oz)
- PLOS-16 Innerliner Overbuff (16oz)
- PCC-2 Carbide Cutter
- PCC-3 Carbide Cutter
- 6068 Adapter for PCC-2
- 6069 Adapter for PCC-3
- PSCS Spiral Cement Tool
- PTS Tire Scraper
- PS-18 Stitcher 1/8"
- PBBR Brass Brush
- PFK Flex Knife
- PWC White Crayon
- PREMA Nailhole Repair Procedures
- PREMA Combi Wall-Poster

PREMA^{HC}

UNIVERSAL BIAS/RADIAL REPAIRS

- Designed for repairing nail hole injuries in tubeless Bias & Radial injuries in the crown area only • Available in either round or square versions • Installs with Prema Ultra Fast dry Vulcanizing Cement

AVAILABLE IN ROUND OR SQUARE



Ascot No.	Mfg. No.	Description	L (in.)	W (in.)	L (mm)	W (mm)	Dia. (IN.)	DIA. (mm)	Qty./Unit
550-00501	PUR-1	Universal Rd. 1	—	—	—	—	1-1/4	32	100
550-00502	PUR-2	Universal Rd. 2	—	—	—	—	2	51	50
550-00503	PUR-3	Universal Rd. 3	—	—	—	—	3	76	50
550-00522	PUS-2	Universal Sq. 2	1-3/4	1-3/4	44	44	—	—	100
550-00533	PUS-3	Universal Sq. 3	2-1/4	2-1/4	57	57	—	—	100
550-01533	PUS-3 BULK	Universal Sq. 3	2-1/4	2-1/4	57	57	—	—	1000
550-00534	PUS-4	Universal Sq. 3	3	3	76	76	—	—	50

COMBI UNITS AND STEMS

- Combi repairs can be used for crown injuries only • Stems should be used when the angle of the injury is GREATER THAN 25°. Repair with the appropriate two-piece stem and repair unit. Combi units may only be used when the angle of the injury is LESS THAN 25°. If the injury angle is GREATER THAN 25°, repair with the appropriate two-piece stem and repair unit



Ascot No.	Mfg. No.	Description	Cutter	Injury Size		Qty./Unit
				(in.)	(mm)	
582-00501	PC-1	Combi 1	PCC-1	1/8"	3	40
582-00502	PC-2	Combi 2	PCC-2	1/4"	6	15
582-00503	PC-3	Combi 3	PCC-3	5/16"	8	10
582-00504	PC-4	Combi 4	PCC-4	3/8"	10	10
582-00522	PCS-2	Stem 2 w/Guide Wire	PCC-2	1/4"	6	20
582-00533	PCS-3	Stem 3 w/Guide Wire	PCC-3	5/16"	8	20
582-00544	PCS-4	Stem 4 w/Guide Wire	PCC-4	3/8"	10	20



CEMENTS, SEALANTS & PATCHES



ULTRA FAST DRY VULCANIZING CEMENT

- Formulated to provide outstanding performance when used in conjunction with PREMATAACK materials
- Contains no ozone depleting chemicals



501-00508

501-00532

501-00519

Ascot No.	Mfg. No.	Description	Fl. Oz.	ML.	Qty./Box
501-00508	PFC-8	Vulcanizing Cement	8	237	10
501-00532	PFC-32	Vulcanizing Cement	32	946	10
501-00519	PIV-9FT	Insert Cement, Flip Top (Flammable)	9	266	12

BEAD SEALER



504-00132

504-01132

Ascot No.	Mfg. No.	Description	Fl. Oz.	ML.	Qty./Box
504-00132	PBS-32	Bead Sealer Spread-On (Flammable)	32	946	10
504-01132	PBSO-32	Bead Sealer Paint-On (Flammable)	32	946	10

PRE-BUFF CLEANER

- Formulated to remove contaminants (such as silicone and mold lubricants) from the innerliner of the tire prior to buffing
- Available in either liquid or aerosol
- Contains no ozone depleting chemicals



505-00516

505-00532

Ascot No.	Mfg. No.	Description	FL. Oz.	ML.	Qty./Box
505-00516	PPC-16	Pre-Buff Cleaner "Aerosol" (Flammable)	16	473	12
505-00532	PPC-32	Pre-Buff Cleaner (Flammable)	32	946	10

INNERLINER OVERBUFF SEALANT

- Designed to restore air retention qualities to the buffed innerliner around the repair after installations
- Can be used in both COLD and HOT vulcanizing systems
- Contains no ozone depleting chemicals



505-05320

Ascot No.	Mfg. No.	Description	Fl. Oz.	ML.	Qty./Box
505-05320	PLOS-16	Innerliner Overbuff Sealant	16	473	10

RADIAL REPAIRS - PASSENGER AND TRUCK



• **Center-Over-Injury repairs are designed for use in the crown, shoulder and sidewall area of radial tires** • They can be installed by either chemical (COLD) vulcanization or heat & pressure (HOT) methods • *For COLD application, install using PREMA Ultra Fast Dry Vulcanizing Cement*

Ascot No.	Mfg. No.	Desc.	L (in.)	W (in.)	L (mm)	W (mm)	# Plies	Qty./Box
575-05109	PR-109	Radial	3	2	77	50	1	20
575-15109	PR-109T	Radial	3	2	77	50	1	80
575-05110	PR-110	Radial	3¼	2¼	83	57	1	20
575-15110	PR-110 Bulk	Radial	3¼	2¼	83	57	1	1000
575-05111	PR-110T	Radial	3¼	2¼	83	57	1	80
575-05112	PR-112	Radial	4¼	3	121	76	1	10
575-25112	PR-112 Bulk	Radial	4¼	3	121	76	1	500
575-15112	PR-112T	Radial	4¼	3	121	76	1	40
575-05113	PR-113	Radial	5	3¼	127	83	1	10
575-05114	PR-114	Radial	5¼	3¼	133	89	1	10
575-05115	PR-115	Radial	3¼	3	95	76	1	10
575-05120	PR-120	Radial	5	3¼	127	83	2	10
575-15120	PR-120 Bulk	Radial	5	3¼	127	83	2	500
575-05122	PR-122	Radial	7	3¼	178	83	2	10
575-05124	PR-124	Radial	8¼	3¼	222	83	2	10
575-05125	PR-125	Radial	5¼	4¼	133	121	2	10
575-05126	PR-126	Radial	10¼	3¼	273	83	3	10
575-05135	PR-135	Radial	7½	5½	191	140	4	10
575-05140	PR-140	Radial	7¼	4¼	197	108	3	10
575-05142	PR-142	Radial	10¼	5½	273	140	4	5
575-05144	PR-144	Radial	13¼	5½	337	140	4	5



CAN BE INSTALLED BY HOT OR COLD METH

• PR115 is used in place of PR110 in heavy duty applications
• PR113 is used in place of PR112 in heavy duty applications



575-05109

BIAS REPAIRS - PASSENGER AND TRUCK

• **Designed with large ply construction for repairing all bias-ply tube and tubeless tires** • These repairs can be used for repairing crown, shoulder and sidewall injuries • *They can be installed by either chemical (COLD) vulcanization or heat and pressure (HOT) methods* • *For COLD application, install using PREMA Ultra Fast Dry Vulcanizing Cement*

Ascot No.	Mfg. No.	Desc.	L (in.)	W (in.)	L (mm)	W (mm)	# Plies	Qty./Unit
562-00501	PB-1	Bias	2-1/4"	-	57	-	1	25
562-00502	PB-2	Bias	3-1/4"	-	83	-	2	10
562-00503	PB-3	Bias	3-3/4"	3-3/4"	96	96	2	10
562-00504	PB-4	Bias	4-3/4"	4-3/4"	121	121	2	10
562-00505	PB-5	Bias	4-3/4"	4-3/4"	121	121	4	10
562-00506	PB-6	Bias	6-1/2"	6-1/2"	165	165	4	10
562-00507	PB-7	Bias	9-3/4"	9-3/4"	248	248	6	5
562-00508	PB-8	Bias	11-3/4"	11-3/4"	298	298	6	5
562-00509	PB-9	Bias	13-3/4"	13-3/4"	349	349	6	5
562-00511*	PB-11*	Bias	17-3/4"	17-3/4"	451	451	8	2

*PB-11 is a made-to-order item.

DESIGNED WITH LARGE PLY





CEMENTS, SEALANTS & PATCHES



REMA STEM INSERTS AND ACCESSORIES

RAD-100 SERIES RADIAL REPAIR UNIT



• REMA TIP TOP offers a variety of radial-ply repair units to meet the diverse demands of today's passenger, truck, and OTR tire applications

• Due to our fully-integrated blue bonding layer and center over injury design, REMA TIP TOP Radial-Ply repair units are suitable for use with

all current vulcanizing systems • For best results, always select the corresponding REMA TIP TOP Stem insert unit, carbide cutter and Special Cement BL (non flammable) or Special Blue Cement (flammable) product for a permanent, reliable repair

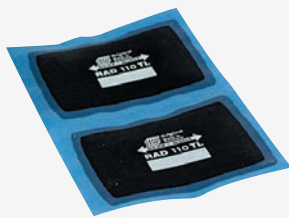

575-00110



• REMA TIP TOP's pre-cured, self-vulcanizing inserts are specially contoured for easy installation • For best results always select the corresponding REMA TIP TOP repair unit, carbide cutter and Special Cement BL (non flammable) or Special Blue Cement (flammable) for a permanent, reliable repair



582-19420



582-19420



582-19311

Ascot No.	Mfg. No.	Description	Plies	Size (in.)	Qty./Unit
575-00110	RAD-110	Radial repair unit	1	2 x 2-3/4	20
575-00115	RAD-115	Radial repair unit	1	3-1/2 x 3	20
575-00116	RAD-116	Radial repair unit	1	2-5/8 x 4	10
576-00120	RAD-120	Radial repair unit	2	4-7/8 x 3	10
576-00122	RAD-122	Radial repair unit	2	6-7/8 x 3	10
576-00124	RAD-124	Radial repair unit	2	8-1/2 x 3	10
576-00125	RAD-125	Radial repair unit	3	4-1/2 x 4-7/8	10
576-00128	RAD-128	Radial repair unit	3	2-7/8 x 13-1/8	10
576-00135	RAD-135	Radial repair unit	4	5-7/8 x 8	10
576-00140	RAD-140	Radial repair unit	3	7-7/8 x 3-15/16	10
576-00142	RAD-142	Radial repair unit	4	10-1/4 x 5	10
576-00144	RAD-144	Radial repair unit	4	13 x 5	10
577-00146	RAD-146	Radial repair unit	4	7-1/4 x 17-1/4	5
577-00150	RAD-150	Radial repair unit	5	23 x 7-1/8	5
577-00152	RAD-152	Radial repair unit	5	23 x 9-1/2	3
577-00155	RAD-155	Radial repair unit	5	10-1/4 x 13-1/8	5
577-00156	RAD-156	Radial repair unit	7	29 x 10-1/2	3
577-00160	RAD-160	Radial repair unit	7	40 x 10-1/4	3
577-00162	RAD-162	Radial repair unit	7	13 x 41-1/4	1
577-00165	RAD-165	Radial repair unit	6	13-1/8 x 16-3/4	3
577-00168	RAD-168	Radial repair unit	7	14 x 30-3/8	1
577-00175	RAD-175	Radial repair unit	8	18 x 21-3/4	3
577-00180	RAD-180	Radial repair unit	2	7-3/4 x 6	5
577-00182	RAD-182	Radial repair unit	3	10 x 7-1/2	5
577-00184	RAD-184	Radial repair unit	3	11-1/2 x 8-1/2	5
577-00185	RAD-185+	Radial repair unit	8	28-3/4 x 20-7/8	1
577-00186	RAD-186	Radial repair unit	2	13-1/2 x 9-3/4	5
577-00188	RAD-188	Radial repair unit	2	18 x 11-1/4	5
577-00190	RAD-190	Radial repair unit	2	22 x 15-3/8	3

Ascot No.	Mfg. No.	Description	Injury (in.)	Qty./Unit
582-19621	193-WL-10	REMA STEM 6 (Wire Lead)	max 1/4	10
582-19820	RS-8	REMA STEM 8	max 5/16	60
582-19420	RS-10	REMA STEM 10	max 3/8	20
582-19430	RS-12	REMA STEM 12	max 1/2	20
582-19311	193-WL-50	REMA STEM 6 (Wire Lead)	max 1/4	50
582-19410	194	REMA STEM 8 (RS-8)	max 5/16	10
468-01120	VT-1120L	Insertion Pulling Wires (626)		



REMA MINICOMBI REPAIR UNITS & ACCESSORIES

- REMA TIP TOP's most popular unit for crown repair of passenger/light truck tires • Our MINICOMBI's are available in a wide range of sizes and establish new standards in one-piece repair technology • For best results always use with REMA TIP TOP carbide cutters and Special Cement BL (non flammable) or Special Blue Cement (flammable) for a permanent, reliable repair
- Improved Blue coating enhances the bonding process



Ascot No.	Mfg. No.	Description	Units/Box
537-00190	190	Awl for Remastem & Minicombi Repairs	—
537-00199	199	Rasp for Remastem & Minicombi Repairs	—
581-67050	A3	1/8" Minicombi	50
581-67010	A3-R	1/8" Minicombi	10
581-67045	A4.5	3/16" Minicombi	40
581-67340	A6	1/4" Minicombi	40
581-67308	A6-R	1/4" Minicombi	8
581-68008	B8-MC	5/16" Minicombi	20
581-68020	B8-MC-R	5/16" Minicombi	8
581-68418	B10	3/8" Minicombi	20
581-68406	B10-R	3/8" Minicombi	6

UNIVERSAL PATCH



- REMA TIP TOP's rubber-reinforced, universal repair units are specially formulated to provide maximum flexibility and strength • These non-directional, center over injury repair units perform flawlessly in both radial or bias-ply tire designs
- For best results, always select the corresponding REMA TIP TOP Stem insert unit, carbide cutter and Special Cement BL (non flammable) or Special Blue Cement (flammable) product for a permanent, reliable repair



Ascot No.	Mfg. No.	Size	Qty.
550-26707	UP-3	1/8"	100
550-26714	UP-4.5P	3/16"	300 in Pail
550-26721	UP-6	1/4"	50
550-26738	UP-6P	1/4"	200 in Pail
550-26745	UP-8	5/16"	50
550-26752	UP-8P	5/16"	150 in Pail



CEMENTS, SEALANTS & PATCHES



REMA TIP TOP BIAS-PLY TIRE REPAIR UNITS

• REMA TIP TOP offers a wide selection of bias-ply (cross-ply) repair units for applications on passenger, truck, OTR, agricultural and industrial bias-ply tires • Due to our fully-integrated blue bonding layer, REMA TIP TOP bias-ply repair units are suitable for use with all current vulcanizing systems • For best results, always select the corresponding REMA TIP TOP Stem insert unit, carbide cutter and Special Cement BL (non flammable) or Special Blue Cement (flammable) for a permanent, reliable repair

Ascot No.	Mfg. No.	Size (in.)	Size (mm)	# Plies	Qty./Box
562-26006	PN-0	1-9/16	39.7	1	50
562-26037	PN-3	4	101.6	2	10
562-26044	PN-4	5-3/4	146	2	10
562-26051	PN-5	6-1/2	165	4	10
562-26068	PN-6	9-1/4	235	6	10
562-26075	PN-7	11-3/4	298.5	6	10
562-26082	PN-8	13-1/2	343	6	5
562-26099	PN-9	15-1/2	393	8	3
562-26109	PN-10	17-3/4	450.8	8	3
563-00200	PN-20	10	254	4	10
563-00210	PN-21	14-1/2	368.3	4	5
563-00220	PN-22	20	508	4	3
563-00230	PN-23	10	254	6	10
563-00240	PN-24	14-1/2	368.3	6	5
563-00250	PN-25	20	508	6	3
563-00400	PN-40	7	177.8	4	2
563-00410	PN-41	8-3/4	222.3	6	2
563-00420	PN-42	10-1/4	260.3	8	2
562-26212	FRU1-MP	2-1/2	63	1	25
562-26213	FRU1-P	2-1/2	63	1	100
562-26314	FRU2-MP	3-1/4	82.55	2	25
562-26315	FRU2-P	3-1/4	82.55	2	100



PRE-BUFF CLEANER

• Specially formulated to dissolve mold-release lubricants and other contaminants creating a clean surface prior to innerliner buffing • Available in spout-top liquid or spray-top aerosol dispensers • CFC-free formula requires shorter drying times • Same formula for tube or tire preparation

Ascot No.	Mfg. No.	Description	Qty./Box
505-00071	71	Pre-Buff Rubber Cleaner 1 Qt. Spout Top Can	6
505-00170	70F	Pre-Buff Cleaner (Flammable) - 16 Oz.	12
505-00171	71-F	Pre-Buff Cleaner (Flammable) - 1 Qt. Spout Top Can	6
532-06020	6020	16 Oz. Aluminum Cement Dispenser with Brush Top	1
532-06021	6021	Replacement Brush Lid for 6020 Cement Dispenser	—



505-00171



SPECIAL CEMENT BL™

• The key to REMA TIP TOP's exclusive Blue Bonding System, Special Cement BL creates a nearly indestructible bond between tire and repair unit

• Specifically designed for the application of REMA TIP TOP Radial, Bias-Ply and Universal, Minicombi & RemaStem repair units • Use for chemical installation of REMA TIP TOP blue bonding layer repair units, Blue Floater Gum and chemical vulcanizing compounds • REMA TIP TOP's newest Special Blue Cement (flammable) is free of CFC and aromatic compounds



502-40541

502-51388



Ascot No.	Mfg. No.	Description	Qty./Box
502-40541	BL-8F	Special Blue Cement (flammable), 8 Oz. Brush Top Can	12
502-51388	BL-32F	Special Blue Cement (flammable), 32 Oz. Can	6

RIM/BEAD SEALER AND INNERLINER REPAIR SEALANT

• REMA TIP TOP offers two distinct Bead Sealer formulations designed to prevent leaks between the tire and rim • Designed to be applied to tire beads during the mounting process • Ideally suited for use with new or old tires • No drip formula is highly viscous with an extended shelf life • CFC-free formula requires shorter drying times • Properly applied, Repair Sealer creates an airtight seal around a finished repair, over buffed areas or porous tire innerliners • Prudent use of Repair Sealer maintains the integrity of the repair.vulcanizing uncured rubber

- Flammable Version Available: F Series
- No Drip Version available: ND Series



505-00176

504-09600



Ascot No.	Mfg. No.	Description	Qty./Box
504-09600	960F	Rim & Bead Sealer w/Brush Cap. CFC-Free Formula (Flammable) 32 Oz.	6
504-09601	960ND	Rim & Bead Sealer w/Brush Cap. No Drip Formula - 32 Oz. Can	6
505-00176	76F	Innerliner Sealer Can (Flammable) - 16 Oz.	6

AEROSOL PRE-BUFF CLEANER

• Non-flammable • Prepares rubber for easy tire repairs • Removes contaminants • Dries fast & leaves no residue • 16 oz. per can • QUANTITY: 12 cans per case



505-71216

Ascot No.	Mfg. No.	Description
505-71216	71216	Aerosol Pre-Buff Cleaner (Non-Flammable)

HEAVY DUTY TIRE REPAIR CABINET

Features sliding storage drawers with rollers.

- Size: 19.6" x 10" x 26"
- 2 shelves inside (3 storage levels)
- 2 tool hook sets on two inside doors
- 2 sliding storage drawers with rollers
- Switch-to-open handle
- Optional shelf available
- Weight: 36 lb.



OPEN

CLOSED

Ascot No.	Mfg. No.	Description
719-12001	TBG-WC12001	Heavy Duty Tire Repair Cabinet
719-12011	TBG-WC12001-01	Optional Shelf for Heavy Duty Tire Repair Cabinet



CEMENTS, SEALANTS & PATCHES



CHEMICALS & CEMENTS

- Cement is fast drying • Wide brush for easy application



504-90005



501-90132



504-90011



504-90016

505-90132

Ascot No.	Mfg. No.	Description	Qty./Box
501-90018	ASV8	Clear Chemical Vulcanizing Cement, 8 oz.	24
501-90132	ASV32BL	Blue Chemical Vulcanizing Cement, Quart	6
504-90005	ABS5 G	Black Bead Sealer, 5-Gallon	—
504-90011	ABSG	Black Bead Sealer, Gallon	4
504-90016	ARS16BK	Black Inner Liner Sealer, 16 oz.	12
505-90008	ARS8	Gray Inner Liner Sealer, 8 oz.	24
505-90032	ABU32	Inner Liner Cleaner, Quart	12
505-90132	ARS32	Gray inner liner sealer, Quart	6

LEAD WIRE PULL THROUGH PATCH/PLUG

- Easiest and most popular method to fill a nailhole and apply a patch in one simple step
- Lead-wire guides the rubber stem through injury
- Stem coated with self vulcanizing material and patch features Versacure bonding gum
- For tread area of bias and radial passenger and truck tires

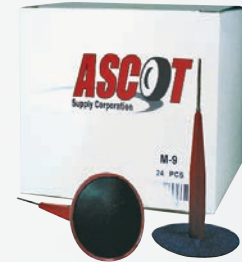

587-01309



FOR TREAD AREA



587-01406

Ascot No.	Description	Qty./Box
587-01303	1/8" Stem Lead Wire Pull Through Patch/Plug	48
587-01306	1/4" Stem Lead Wire Pull Through Patch/Plug	24
587-01309	3/8" Stem Lead Wire Pull Through Patch/Plug	24
587-01406	1/4" Plug-N-Patch: Grey Cushion Gum, Blue Wrap	24
587-01409	3/8" Plug-N-Patch: Grey Cushion Gum, Blue Wrap	24

BIAS HEAVY DUTY UNITS

- ASB series is a cord reinforced soft gum repair
- ACB series is a cord reinforced repair with hard blue gum
- Repair with chemical vulcanizing cement

Ascot No.	Mfg. No.	Description
564-90012	ASB2	Bias Heavy Duty: 2-7/8" (20 per box)
564-90013	ASB3	Bias Heavy Duty: 4-5/8" (10 per box)
564-90014	ASB4	Bias Heavy Duty: 5-3/8" (10 per box)
564-90015	ASB5	Bias Heavy Duty: 7-1/8" (10 per box)
564-90016	ASB6	Bias Heavy Duty: 10" (10 per box)
564-90022	ACB2HD	Bias Heavy Duty: 2-7/8" (20 per box)
564-90111	ACB1HD	Bias Heavy Duty: 2-1/2" (20 per box)



564-90012
Bias Heavy Duty Unit (2-7/8")



564-90013
Bias Heavy Duty Unit (4-5/8")



564-90014
Bias Heavy Duty Unit (5-3/8")



BROWN, 12 STRAND TIRE REPAIR INSERT W/ BLUE PAPER BACKING

- 8" brown • Made in the USA • Extended shelf life
- No leaks • 3rd party testing
- EPA approved • Durable cord body • 100% butyl saturation • 6 repairs per packet • 5 packets per box



Ascot No.	Mfg. No.	Description
571-91964	ATS1964	4" Brown, 12 Strand Tire Repair Insert w/ Blue Paper Backing
571-91968	ATS1968	8" Brown, 12 Strand Tire Repair Insert w/ Blue Paper Backing

HEAVY DUTY 8" REPAIR INSERT KIT

- For use on the wheel • Everything needed to make temporary, emergency repairs to most flat tires caused by nails or other objects up to 1/4" • **KIT INCLUDES:** (30) 8" temporary inserts, metal t-handle insertion tool, metal t-handle probe, lubricant, cutting blade, Allen wrench and instructions
- Blow molded case for easy storage



Ascot No.	Mfg. No.	Description
518-90030	ATS30K-HD	Heavy Duty 8" Repair Insert Kit - 30 Repairs

METAL T-HANDLE TRUCK INSERTION TOOL

- All metal construction • Ergonomically designed • Inserts temporary tire repairs with ease • Includes 5-1/2" replacement needle that can easily be changed



Ascot No.	Mfg. No.	Description
537-90144	TTT	Metal T-Handle Truck Insertion Tool
537-90155	AWRN55	5-1/2" Replacement Insertion Needle

SAFETY SEAL® TRUCK TIRE REPAIR KIT

- Includes everything to make temporary repairs to most flats caused by nails or other objects up to 1/4" • **KIT INCLUDES:** 30-8" (20cm) temporary repairs, Metal T-handle insertion tool, Metal T-handle spiral probe, Special lube, Extra insertion needle, Cutting blades, Allen wrench, and Instructions
- Packed in a sturdy carrying case to fit easily under the seat of a truck



Ascot No.	Mfg. No.	Description
571-22926	SSKTP	Truck Tire Repair Kit

SAFETY SEAL® TRUCK TIRE REPAIR REFILLS

- 24 plies of a custom made high tensile (350 lb break strength) chemical resistant nylon yarn • Each yarn is immersed in proprietary rubber sealant system (250% rubber to yarn) • Patented manufacturing process assures the final Safety Seal® repair has an equal amount of rubber sealant (250% rubber to yarn) throughout the Safety Seal® Repair • **INCLUDES:** 30 8" (20cm) refill repairs per kit



Ascot No.	Mfg. No.	Description
585-30820	SSRT	Truck Tire Repair Refills - 30 8" (20 cm) Repairs

VULCANIZED TUBELESS TIRE REPAIR SEALS

- For emergency repair use only • String repairs are not designed to be used in lieu of a permanent repair • Repair a punctured tire in a matter of minutes • Made from high-strength yarn and butyl rubber



Ascot No.	Mfg. No.	Description	Qty./Box
538-60541	1012060T54TS	4" Orange String Repair	60
585-30581	1012030T58TS	8" Orange String Repair	30
585-10071	105B100PD7AS	8" Thin Black String Repair	100



Ascot Supply Corp. does not recommend "temporary" tire repairs. All repairs should perform the function of filling or replacing the injured section as recommended by the RMA and other industry associations.

CABINETS



HEAVY DUTY TIRE REPAIR CABINET

Features sliding storage drawers with rollers.

- SIZE: 19.6" x 10" x 26"
- 2 shelves inside (3 storage levels)
- 2 tool hook sets on two inside doors
- 2 sliding storage drawers with rollers
- Switch-to-open handle
- Optional shelf available
- WEIGHT: 36 lbs.



719-12001

Ascot No.	Mfg. No.	Description
719-12001	TBG-WC12001	Heavy Duty Tire Repair Cabinet
719-12011	TBG-WC12001-01	Optional Shelf for Tire Repair Cabinet

18-DRAWER METAL STORAGE CABINET

- CABINET SIZE: 33-3/4" (W) x 11-3/4" (D) x 10-3/4" (H)
- DRAWER SIZE: 4-7/8" (W) x 11-1/4" (D) x 2-3/4" (H)
- Modular drawer design for efficiency and organization
- Heavy-duty, welded steel construction provides strength and stability
- Drawers feature stoppers to prevent accidental pulling or spilling
- Full-width handles and easy glide runners
- Shipped fully assembled and ready to use
- WEIGHT: 45 lbs.



719-00018

Ascot No.	Mfg. No.	Description
719-00018	18D	18-Drawer Metal Storage Cabinet

32-BIN METAL STORAGE CABINET

- CABINET SIZE: 33-3/4" (W) x 8-1/2" (D) x 19-1/4" (H)
- DRAWER SIZE: 4" (W) x 8-3/8" (D) x 4-1/2" (H)
- Keeps your tools and accessories organized and accessible
- Heavy-duty, welded steel construction provides strength and stability
- Hemmed bin fronts for retaining parts
- Mounting holes located in the top and bottom
- Shipped fully assembled and ready to use
- WEIGHT: 37 lbs.

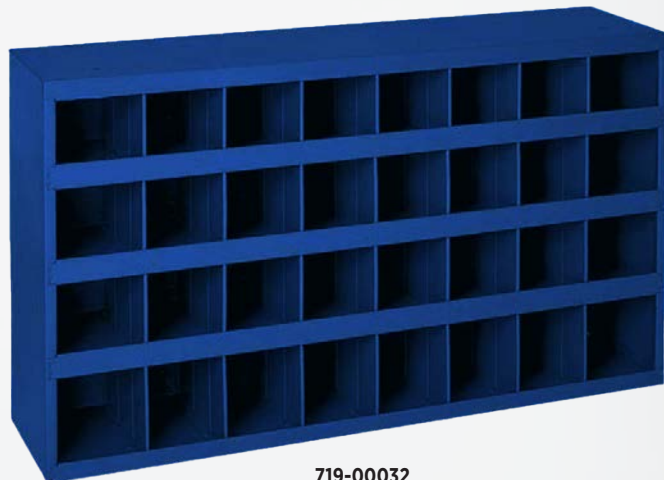

719-00032

Ascot No.	Mfg. No.	Description
719-00032	32B	32-Bin Metal Storage Cabinet

*Actual product appearance may vary

AIR BUFFERS & DRILLS



HIGH-SPEED TIRE BUFFER WITH QUICK CHANGE CHUCK

- Equipped with a quick change chuck to allow for rapid changes to a variety of tire repair tasks
- **APPLICATIONS:** Ideal for scuffing, grinding, cleaning and many other uses requiring high speed and is equipped with safety throttle lever
- Includes one quick-change adapter • **FREE SPEED:** 20,000 RPM • **MADE IN USA**



157-06010

Ascot No.	Mfg. No.	Description
157-06010	SLP-6010	High-Speed Tire Buffer with Quick Change Chuck
157-16010	SLP-6010REK	Above with Rear Exhaust Hose Kit

HIGH SPEED TIRE BUFFER KIT

- **Jacobs chuck for holding buffing accessories** • Lock-off throttle • **APPLICATIONS:** Tire patchwork, roughing areas for recapping and cleaning tire moldings • **FREE SPEED:** 20,000 RPM • **MADE IN USA**



157-04038

Ascot No.	Mfg. No.	Description
157-04038	SLP-4038	High-Speed Tire Buffer with Jacob's Chuck
157-14038	SLP-4038REK	Above with Rear Exhaust Hose Kit

HEAVY DUTY SKIVING TOOL

- **APPLICATIONS:** Excellent for skiving work due to the more substantial gear package which contributes to durability
- **FREE SPEED:** 2,800 RPM • Rear exhaust performance • Equipped with safety throttle lever
- Includes one quick-change adapter • **MADE IN USA**



157-06550

Ascot No.	Mfg. No.	Description
157-06550	SLP-6550	Heavy Duty Skiving Tool
157-16550	SLP-6550REK	Above with Rear Exhaust Hose Kit

LOW-SPEED TIRE BUFFER WITH QUICK CHANGE CHUCK

- **FREE SPEED:** 2,800 RPM
- 90 PSI Required air pressure
- 1/4"NPT. Air Inlet • 3/8" required hose size • **WEIGHT:** 2.25 lb. • 8.5" in length • Quick change chuck for fast change of buffing accessories



157-06510

Ascot No.	Mfg. No.	Description
157-06510	SLP-6510	Low-speed Tire Buffer with Quick Change Chuck
157-16510	SLP-6510REK	Above with Rear Exhaust Hose Kit

LOW SPEED TIRE BUFFER WITH QUICK CHANGE SLIP CHUCK

- **Brass bushings provide performance and durability in tough working conditions**
- Includes whip hose and exhaust hose • Quick change slip chuck for fast and easy change of buffing wheel • Built-in regulator • Lock off throttle to prevent accidental start ups • Rear exhaust directs air away from the work area
- **APPLICATIONS:** Ideal for patchwork, roughing areas for recapping and cleaning tire moldings
- Overhose Kit also Available Separately (175-00873)



158-10873

Ascot No.	Mfg. No.	Description
158-10873	A873K	Low Speed Tire Buffer with Quick Change Slip Chuck

HIGH SPEED BUFFER KIT WITH QUICK CHANGE CHUCK

- **Quick change chuck for holding buffing accessories**
- **Lock-off throttle** • **FREE SPEED:** 22,000 RPM
- **APPLICATIONS:** Tire patchwork, roughing areas for recapping and cleaning tire moldings • Includes overhose kit



158-11871

Ascot No.	Mfg. No.	Description
158-11871	A871K-QC	High Speed Buffer Kit with Quick Change Chuck

AIR BUFFERS & DRILLS



HIGH SPEED TIRE BUFFER WITH OVERHOSE KIT

- Jacobs chuck for holding buffing accessories • Lock-off throttle • **FREE SPEED:** 22,000 RPM • **APPLICATIONS:** Tire patchwork, roughing areas for recapping and cleaning tire moldings • Includes overhose kit



158-10871

Ascot No.	Mfg. No.	Description
158-10871	A871K	High Speed Tire Buffer with Overhose Kit

LIGHTED LOW-SPEED BUFFER WITH QUICK-CHANGE CHUCK

- Provides light inside the tire without the use of batteries or other external power sources • Volt-Aire patented technology turns the motor into a working generator to bring electricity and light to the work surface for enhanced visibility, safety and productivity • Geared design provides high torque but low speed to prevent burning of work surface • Quick-change chuck allows operator to make rapid changes to a variety of tool accessories • **MADE IN USA**



157-06520

Ascot No.	Mfg. No.	Description
157-06520	SLP-6520L	Lighted Low-Speed Tire Buffer with Quick Change Chuck
157-16520	SLP-6520REK	Above with Rear Exhaust Hose Kit



HEAVY DUTY AIR LOW SPEED TIRE BUFFER

- **APPLICATIONS:** For quick work of patchwork and roughing up low areas for recapping, tire scuffing and cleaning tire moldings • Free speed up to 3,000 RPM • 1/2 HP motor



157-01327

Ascot No.	Mfg. No.	Description
157-01327	IR-327LS	Heavy Duty Air Low Speed Tire Buffer - Includes Over Hose



HIGH-SPEED TIRE BUFFER WITH JACOBS CHUCK

- Provides plenty of power with it's .5 horsepower motor and 22,000 RPM, rear exhaust performance • **APPLICATIONS:** Ideal for patchwork, roughing areas for recapping and cleaning tire moldings • Equipped with safety throttle lever



158-00871

Ascot No.	Mfg. No.	Description
158-00871	CP-871K	High-Speed Tire Buffer with Jacobs Chuck - Includes Over Hose

LOW SPEED TIRE BUFFER KIT

- Quick change slip chuck for fast and easy change of buffing wheel
- Adjustable speed regulator for precise control • Lock-off throttle to prevent accidental start ups
- Rear exhaust directs air away from work area • **FREE SPEED:** 2,800 RPM



158-00873

Ascot No.	Mfg. No.	Description
158-00873	CP-873K	Low Speed Tire Buffer Kit - Includes Over Hose

TIRE REPAIR TOOLS & ACCESSORIES



RPG AIR POWERED TIRE REPAIR VACUUM

- **Quick change from blow to vacuum function**
- **KIT INCLUDES:** Plastic body gun, dust bag, 2 extension tubes, shop brush, flat tube, tiny tube



537-00003



Ascot No.	Mfg. No.	Description
537-00003	VBG2	RPG Air Powered Tire Repair Vacuum

TIRE REPAIR AIR TOOL ACCESSORIES

Ascot No.	Mfg. No.	Description
173-00018	QC18	Quick Chuck Adapter W/ Collar
173-00019	QC19	Quick Chuck Adapter W/ Spacer 1" x 3/8" Thread
173-00020	QC20	Quick Chuck Adapter For 1/8" Shank
173-00022	QC22	Quick Chuck Adapter For 1/4" Shank
173-00023	QC23	Quick Chuck Adapter For 5/16" Shank
173-09150	SLP-9150	Jacobs 3/8" Precision Chuck and Key
173-09165	SLP-9165	Quick Change Chuck - 3/8"-24 Mounting Thread
173-09166	SLP-9166	Quick Change Chuck - 1/2"-13 Mounting Thread
173-09167	SLP-9167	Quick Change Chuck - 1/2"-20 Mounting Thread
173-09201	SLP-9201	1-11/16" x 3/8"-24 Chuck Adapter w/Washer & Nut
173-09202	SLP-9202	2-3/4" x 3/8"-24 Chuck Adapter w/Nut & Wheel Spacer
173-09211	SLP-9211	1-7/8" x 3/8"-24 Threaded Adapter w/Washer & Nut
173-09212	SLP-9212	2-1/4" x 3/8"-24 Threaded w/ Nut & Wheel Spacer
173-09213	SLP-9213	1-15/16" Adapter w/Set Screw for 1/8" Shank
173-09214	SLP-9214	1-15/16" Adapter w/Set Screw for 3/16" Shank
173-09215	SLP-9215	1-15/16" Adapter w/Set Screw for 1/4" Shank
173-09216	SLP-9216	1-15/16" Adapter w/Set Screw for 5/16" Shank
173-09400	SLP-9400	Overhose Kit



173-09400



173-09150



173-09165



173-09201



173-09202



173-09211



173-09212



173-09213



173-09215



173-09216

TIRE REPAIR TOOLS & ACCESSORIES



MISCELLANEOUS TIRE REPAIR TOOLS



Ascot No.	Mfg. No.	Description
537-90002	SEPG	Plastic Pistol Grip Handle - Short end load
537-90003	OETT	Plastic T-Handle w/ 3-1/2" needle - end load
537-90005	OE11	Heavy Duty Screwdriver-Type Handle: 11"
537-90006	TST	Chrome Plated T-Handle with 3" Replaceable Needle - end load

Ascot No.	Mfg. No.	Description
537-90009	SPPG	Plastic Pistol Grip Handle Spiral Probe
537-90019	TSPRB	Chrome Plated T-Handle Spiral Probe
537-90035	WRN35	Replacement Needle: 3-1/2" - end load
537-90045	WRN45	Replacement Needle: 4-1/2" - end load

Ascot No.	Mfg. No.	Description
537-90119	PRBR	Replacement Spiral Probe
537-90150	P150	Heavy Duty Screwdriver-Type Handle Barbed Rasp
537-90200	TSBRP	Chrome Plated T-Handle with Barbed Rasp
537-90201	PPG	Plastic Pistol Grip Handle Barbed Rasp



TIRE REPAIR KNIVES

• Rubber must be cleaned and hole injuries must be cleaned and roughened before inserting repair units



531-60570



531-75190



531-75200



531-75310

Ascot No.	Mfg. No.	Description	Blade Length	Qty./Box
531-60570	X751N	High carbon steel, hawk bill notch, glaze finish, round burnt finish handle (riveted)	2" / 51mm	12
531-75190	X2T	High carbon steel, taper point, glaze finish, round burnt finish handle (riveted)	4" / 102mm	12
531-75310	X3N	High carbon steel, round point, thin skiver, glaze finish, round burnt finish handle	4-7/8" / 124mm	12
531-75200	X1S	High carbon steel, square point, glaze finish, round burnt finish handle (riveted)	2-1/2" / 64mm	12
531-75170	X2S		3" / 76mm	12
531-75330	X3S		3-5/8" / 93mm	12
531-75370	X4S		3-7/8" / 99mm	12
531-75440	X5S		4-1/4" / 108mm	12

RUBBER KNIFE

• High carbon steel, square point, glaze finish, round burnt finish handle (riveted)



531-60150

Ascot No.	Mfg. No.	Description	Blade Length	Qty./Box
531-60070	X4x1S	High carbon steel, square point, glaze finish, round burnt finish handle (riveted)	4" x 1" / 102 x 26mm	12
531-60090	X5x1S		5" x 1" / 127 x 26mm	
531-60130	X6x1S		6" x 1" / 152 x 26mm	
531-60150	X8x11/8S		8" x 1-1/8" / 203 x 29mm	
531-60170	X10x11/4S		10" x 1-1/4" / 254 x 32mm	

FLEXIBLE TIRE REPAIR KNIFE

• High carbon steel, round point skiver, glaze finish, round burnt finish handle (riveted)



531-75150

Ascot No.	Mfg. No.	Description	Blade Length	Qty./Box
531-75150	X2RF	High carbon steel, round point skiver, glaze finish, round burnt finish handle (riveted)	4" / 102mm	12

SKIVING KNIFE



531-70030



531-71050

Ascot No.	Mfg. No.	Description
531-70030	70030	4-1/2" Handle for X2 Blades
531-71050	71050	10 Replacement blades

OTHER KNIVES

Ascot No.	Mfg. No.	Description
531-60300	60300	4" x 1" Curved Notch Repair Knife
531-60310	60310	6" x 1-1/2" 5-Notch Trim Knife
531-75220	75220	3/8" Curved Point Shoe Knife
531-75310	X3N	4-7/8" Round Point Skiving Knife

SLOTTED FINISHING RASPS



539-02203



539-02206

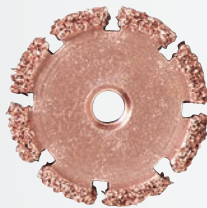

539-02207

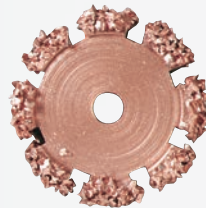

539-02208

Ascot No.	Mfg. No.	Grit	Description
539-02203	2203	36-Grit	2" x 3/16" Slotted Finishing Rasp
539-02204	2204	36-Grit	2" x 3/16" Slotted Finishing Rasp
539-02205	2205	16-Grit	2" x 3/8" Slotted Finishing Rasp
539-02206	2206	16-Grit	2" x 3/8" Slotted Finishing Rasp
539-02207	2207	36-Grit	2" x 1/2" Slotted Finishing Rasp
539-02208	2208	16-Grit	2" x 1/2" Slotted Finishing Rasp
539-02209	2209	36-Grit	2" x 3/4" Slotted Finishing Rasp
539-02210	2210	16-Grit	2" x 3/4" Slotted Finishing Rasp
539-02241	2241	36-Grit	2" x 1" Slotted Finishing Rasp

LARGE VARIETY OF SHAPES & SIZES

DURABLE & EFFICIENT

TIRE REPAIR TOOLS & ACCESSORIES



CONTOUR CUP RASPS

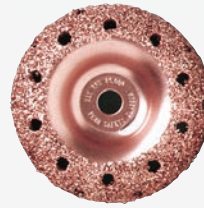

539-06310

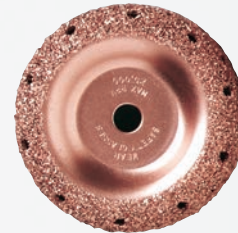

539-06411

LARGE VARIETY OF SHAPES & SIZES

DURABLE & EFFICIENT

Ascot No.	Mfg. No.	Grit	Description
539-06261	TCW210	36-Grit	2" x 1-3/8" - 3/8" Arbor Hole
539-06260	TCW210	16-Grit	2" x 1-3/8" - 3/8" Arbor Hole
539-06360	TCW310	36-Grit	3" x 1" - 3/8" Arbor Hole
539-06361	TCW310	16-Grit	3" x 1" - 3/8" Arbor Hole
539-06310	TCW315	36-Grit	3" x 1-1/2" - 3/8" Arbor Hole
539-06311	TCW315	16-Grit	3" x 1-1/2" - 3/8" Arbor Hole
539-06312	TCW315	36-Grit	3" x 1-1/2" - 1/2" Arbor Hole
539-06313	TCW315	16-Grit	3" x 1-1/2" - 1/2" Arbor Hole
539-06314	TCW315	36-Grit	3" x 1-1/2" Vented - 3/8" Arbor Hole
539-06315	TCW315	16-Grit	3" x 1-1/2" Vented - 3/8" Arbor Hole
539-06316	TCW315	36-Grit	3" x 1-1/2" Vented - 1/2" Arbor Hole
539-06317	TCW315	16-Grit	3" x 1-1/2" Vented - 1/2" Arbor Hole
539-06410	TCW415	36-Grit	4" x 1-1/2" - 1/2" Arbor Hole
539-06411	TCW415	16-Grit	4" x 1-1/2" - 1/2" Arbor Hole
539-06412	TCW415	36-Grit	4" x 1-1/2" - 5/8" Arbor Hole
539-06413	TCW415	16-Grit	4" x 1-1/2" - 5/8" Arbor Hole
539-06414	TCW415	36-Grit	4" x 1-1/2" Vented - 1/2" Arbor Hole
539-06415	TCW415	16-Grit	4" x 1-1/2" Vented - 1/2" Arbor Hole
539-06416	TCW415	36-Grit	4" x 1-1/2" Vented - 5/8" Arbor Hole
539-06417	TCW415	16-Grit	4" x 1-1/2" Vented - 5/8" Arbor Hole

B&J NON-REGRITTABLE COPPER CONTOUR WHEELS

• The B&J Contour Wheels have a convex contour, which has proven to be particularly suitable for repairs inside the tire • Smaller models are almost completely covered with grit on their surface, so they can be used at any angle • Also ideal for sidewall machining • The variety of grain sizes available provides an optimum surface for every application



539-10136



539-11036



539-10936



539-10416

Ascot No.	Mfg. No.	Grit	Description
539-10116	332001-16	16 Grit	2" x 1" Copper Contour Wheel (50 x 25mm) AH 3/8"
539-10123	332001-23	23 Grit	2" x 1" Copper Contour Wheel (50 x 25mm) AH 3/8"
539-10136	332001-36	36 Grit	2" x 1" Copper Contour Wheel (50 x 25mm) AH 3/8"
539-10160	332001-60	60 Grit	2" x 1" Copper Contour Wheel (50 x 25mm) AH 3/8"
539-11016	332010-16	16 Grit	3" x 1" Copper Contour Wheel (76 x 25mm) AH 3/8"
539-11023	332010-23	23 Grit	3" x 1" Copper Contour Wheel (76 x 25mm) AH 3/8"
539-11036	332010-36	36 Grit	3" x 1" Copper Contour Wheel (76 x 25mm) AH 3/8"
539-11060	332010-60	60 Grit	3" x 1" Copper Contour Wheel (76 x 25mm) AH 3/8"
539-10916	332009-16	16 Grit	3" x 1.5" Copper Contour Wheel (76 x 38mm) AH 3/8"
539-10923	332009-23	23 Grit	3" x 1.5" Copper Contour Wheel (76 x 38mm) AH 3/8"
539-10936	332009-36	36 Grit	3" x 1.5" Copper Contour Wheel (76 x 38mm) AH 3/8"
539-10960	332009-60	60 Grit	3" x 1.5" Copper Contour Wheel (76 x 38mm) AH 3/8"
539-10416	332004-16	16 Grit	4" x 1.5" Copper Contour Wheel (102 x 38mm) AH 3/8"
539-10423	332004-23	23 Grit	4" x 1.5" Copper Contour Wheel (102 x 38mm) AH 3/8"
539-10436	332004-36	36 Grit	4" x 1.5" Copper Contour Wheel (102 x 38mm) AH 3/8"
539-10460	332004-60	60 Grit	4" x 1.5" Copper Contour Wheel (102 x 38mm) AH 3/8"

B&J NON-REGRITTABLE COPPER BUFFOUT WHEELS

- Buffout Tools are ideal for all types of tire repairs • With a variety of sizes and shapes repairs can be carried out quickly and effectively • Due to the narrow tool width of 3 mm and more, the area to be repaired remains as small as necessary and saves unnecessary filling material afterwards • The special design makes the tools durable and efficient

Ascot No.	Mfg. No.	Grit	Description
539-15616	332056-16	16-Grit	Flat Faced Buffout Wheel 2" x 3/16" (50 x 5mm)
539-15636	332056-36	36-Grit	Flat Faced Buffout Wheel 2" x 3/16" (50 x 5mm)
539-15816	332058-16	16-Grit	Flat Faced Buffout Wheel 2" x 1/4" (50 x 7mm)
539-15836	332058-36	36-Grit	Flat Faced Buffout Wheel 2" x 1/4" (50 x 7mm)
539-16316	332063-16	16-Grit	Flat Faced Buffout Wheel 2" x 3/8" (50 x 10mm)
539-16336	332063-36	36-Grit	Flat Faced Buffout Wheel 2" x 3/8" (50 x 10mm)
539-16416	332064-16	16-Grit	Round Faced Buffout Wheel 2" x 1/2" (50 x 13mm)
539-16436	332064-36	36-Grit	Round Faced Buffout Wheel 2" x 1/2" (50 x 13mm)
539-16516	332065-16	16-Grit	Round Faced Buffout Wheel 2" x 3/4" (50 x 19mm)
539-16536	332065-36	36-Grit	Round Faced Buffout Wheel 2" x 3/4" (50 x 19mm)

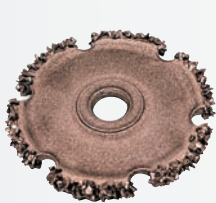

539-15616



539-15816



539-16316

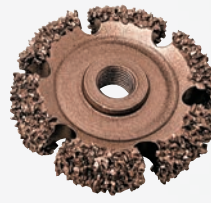

539-16416



539-16516

B & J AIRBOT BUFFOUT WHEELS

- The new AIRBOT® series not only look aggressive, they also work aggressively • With their open design and the angled setup they are much more efficient in getting the job done than any predecessors • Improved cooling • Rounder buffing profile • Longer lifetime • Faster grinding cycles



539-18516/36



539-18616/36



539-18716/36



539-18816/36



539-15516



539-18416

Ascot No.	Mfg. No.	Description
539-18516	132185-16	RFBOT AIRBOT Ø2"x 3/16", AH 3/8", Grit 16 Buffout Wheel
539-18536	132185-36	RFBOT AIRBOT Ø2"x 3/16", AH 3/8", Grit 36 Buffout Wheel
539-18616	132186-16	RFBOT AIRBOT Ø2"x 1/4", AH 3/8", Grit 16 Buffout Wheel
539-18636	132186-36	RFBOT AIRBOT Ø2"x 1/4", AH 3/8", Grit 36 Buffout Wheel
539-18716	132187-16	RFBOT AIRBOT Ø2"x 3/8", AH 3/8", Grit 16 Buffout Wheel
539-18736	132187-36	RFBOT AIRBOT Ø2"x 3/8", AH 3/8", Grit 36 Buffout Wheel
539-18816	132188-16	RFBOT AIRBOT Ø2"x 1/2", AH 3/8", Grit 16 Buffout Wheel
539-18836	132188-36	RFBOT AIRBOT Ø2"x 1/2", AH 3/8", Grit 36 Buffout Wheel
539-18416	132184-16	RFBOT AIRBOT Ø4"x 1/2", AH 1/2", Grit 16 Buffout Wheel
539-18436	132184-36	RFBOT AIRBOT Ø4"x 1/2", AH 1/2", Grit 36 Buffout Wheel
539-15516	132155-16	RFBOT AIRBOT Ø6"x 1/2", AH 1/2", Grit 16 Buffout Wheel
539-15536	132155-36	RFBOT AIRBOT Ø6"x 1/2", AH 1/2", Grit 36 Buffout Wheel

B & J HD BUFFOUT WHEELS

- Improved durability • Aggressive and efficient
- Longer lifetime than conventional "16-grit" carbides



539-33010



539-33009

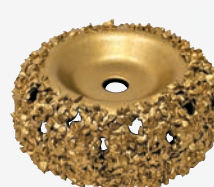

539-33004



539-33017

Ascot No.	Mfg. No.	Description
539-32056	332056-HD	2" x 3/16" RFBOT HD Buffout Wheel
539-32058	332058-HD	2" x 1/4" RFBOT HD Buffout Wheel
539-32063	332063-HD	2" x 3/8" RFBOT HD Buffout Wheel
539-32064	332064-HD	2" x 1/2" RFBOT HD Buffout Wheel
539-32065	332065-HD	2" x 3/4" RFBOT HD Buffout Wheel
539-33010	332010-HD	3" x 1" Contour Wheel HD Grit 3/8" AH
539-33009	332009-HD	3" x 1.5" Contour Wheel HD Grit 3/8" AH
539-33004	332004-HD	4" x 1.5" Contour Wheel HD Grit 3/8" AH
539-33017	332017-HD	4" x 1.5" Contour Wheel HD Grit 1/2" AH



TIRE REPAIR TOOLS & ACCESSORIES



FLARED CONTOUR WHEELS

The unique profile of the Flared Contour Wheels properly matches the shape of the tire.

- Provides wide, level contact with surface
- Efficient use of the entire tool
- Easier to use - less operator fatigue
- Reduced buffing time



538-10700

538-11200



538-12200



Ascot No.	Mfg. No.	Description
538-10000	RH100	1-3/4" Contour Wheel, 3/8" Bore, SSG 170
538-10200	RH102	1-3/4" Contour Wheel, 3/8" Bore, SSG 230
538-13017	RH130-170	2" Contour Wheel, 3/8" Bore, SSG 170
538-13023	RH130-230	2" Contour Wheel, 3/8" Bore, SSG 230
538-10700	RH107	2-1/2" Contour Wheel, 3/8" Bore, SSG 170
538-10900	RH109	2-1/2" Contour Wheel, 3/8" Bore, SSG 230
538-11100	RH111	2-1/2" Contour Wheel, 3/8" Bore, SSG 390
538-11200	RH112	3" Contour Wheel, 3/8" Bore, SSG 170
538-11400	RH114	3" Contour Wheel, 3/8" Bore, SSG 230
538-11600	RH116	3" Contour Wheel, 3/8" Bore, SSG 390
538-11800	RH118	3-1/2" Contour Wheel, 3/8" Bore, SSG 170
538-12000	RH120	3-1/2" Contour Wheel, 3/8" Bore, SSG 230
538-12200	RH122	3-1/2" Contour Wheel, 3/8" Bore, SSG 390

* Designed to fit the Bandag pre-8400 series buffers

B & J SUPER PATRIOT CONTOUR WHEEL

- Super Patriot's patented design is significantly efficient since cooling is achieved throughout the entire working surface of the tool due to the concave/convex base design
- Customers' feedback after using the Patriot carbides is based on the products significantly longer life vs. conventional carbides



539-28646

Ascot No.	Mfg. No.	Description
539-28646	133286-460	3" X 1-1/4" CWSP 460 grit 3/8" AH

POLYPLUGS FOR FLARED CONTOUR WHEELS

- Easily fits inside the contour wheel
- Compensates for mounting inaccuracies
- Reduces vibration for smoother, quieter, more comfortable operation
- Reusable!



Ascot No.	Mfg. No.	Description
538-15000	RH150	1-3/4" PolyPlug
538-15100	RH151	2" PolyPlug
538-15200	RH152	2-1/2" PolyPlug
538-15400	RH154	3" PolyPlug
538-15600	RH156	3-1/2" PolyPlug

ECONOMY FLARED CONTOUR WHEEL

- Proven Rubberhog shape
- Uses the Standard Grit coating for an economical solution
- Reduced aggressiveness for the less experienced user
- Much safer than black stones!



538-13000

Ascot No.	Mfg. No.	Description
538-13000	RH130	2" Contour Wheel, 3/8" Bore, 60 Grit

CARBIDE CUTTING TOOLS

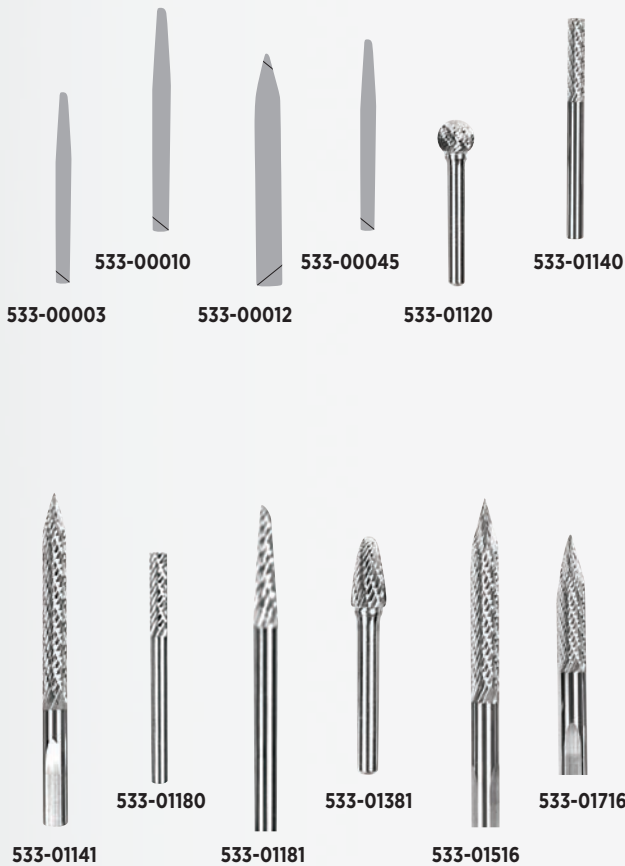

Ascot No.	Mfg. No.	Description
533-00003	CB3	1/8" (3mm) Pointed End
533-00010	CB10	3/8"(10mm) Pointed End
533-00012	CB12	1/2" (12mm) Pointed End
533-00045	CB4.5	1/8" (4.5mm) Pointed End
533-01120	BU12B	1/2" Ball Burr
533-01140	BU14R	1/4" Router Burr
533-01141	BU14TR	1/4" Long Taper Burr
533-01180	BU18R	1/8" Router Burr
533-01181	BU18T	1/8" Taper Burr
533-01182	BU18TL	1/8" Taper Burr, 3" Overall Length
533-01381	BU38T	3/8" Tree Burr
533-01516	BU516NR	5/16" Long Taper Burr
533-01716	BU716N	7/16" Long Taper Burr
533-01732	BU732N	7/32" Long Taper Burr

BUFFING STONES FOR STEELBELTED TIRES



Ascot No.	Mfg. No.	Description
534-80001	A-1	Large Cone - 3/4" Stone Diameter
534-80005	A-5	Small Cone - 3/4" Stone Diameter
534-80011	A-1B	Large Cone 3/4" Stone Diameter (Brown)
534-80015	A-15	Pencil Point - 1/4" Stone Diameter
534-80024	A-24	Round Head Pencil - 1/4" Stone Diameter
534-80036	A-36	Stone Disc - 1-3/4" Diameter
534-80037	A-37	Stone Disc - 1-1/4" Stone Diameter
534-80115	A-15B	Pencil Point - 1/4" Stone Diameter-Brown
534-80136	A-36B	Stone Disc - 1-3/4" Diameter -Brown
534-80137	A-37B	Stone Disc - 1-1/4" Diameter-Brown
534-81115	A-15SS	Pencil Point 1/4" Stone Diameter, Stainless Steel Shank

BUFFING WHEEL

- For use on tires or tubes
- Coarse grit, round nose
- Tungsten carbide



539-10001

Ascot No.	Mfg. No.	Description
539-10001	BC-1	Buffing Wheel, 2-1/2" diameter

TIRE REPAIR TOOLS & ACCESSORIES



CUTTING PLIER - BOX JOINT

- Perfectly mated cutters, scientifically heat treated to hold their edge
- Precision made of fine polished, high carbon steel
- Distinctive CHANNELLOCK BLUE comfort grips

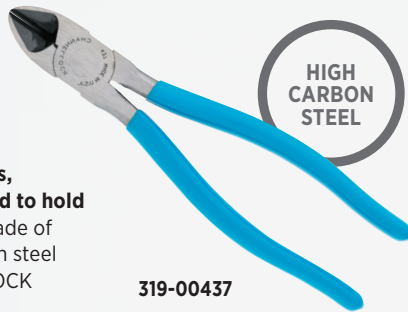

HIGH CARBON STEEL

319-00437

Ascot No.	Mfg. No.	Length	Weight	Jaw Length	Joint Thickness	Joint Width	Cutter Length
319-00437	437	7" / 175mm	7.84 Oz. / 222 Gr.	1" / 25.5mm	31/64" / 12.5mm	15/16" / 24mm	1" / 25.5mm

CURVED DIAGONAL CUTTING PLIER - LAP JOINT

- Curved diagonal for maximum pulling leverage
- Perfectly mated cutter, heat treated to hold its edge
- Polished high carbon drop forged steel
- CHANNELLOCK BLUE comfort grips



HIGH CARBON STEEL

319-00447

Ascot No.	Mfg. No.	Length	Weight	Jaw Length	Joint Thickness	Joint Width	Cutter Length
319-00447	447	7-3/4" / 195mm	10.67 Oz. / 302 Gr.	1-1/32" / 26mm	1/2" / 12.5mm	1-1/16" / 27mm	1-1/32" / 26mm

8" END CUTTING PLIERS

- Offer precision machined knife and anvil style cutting edges to ensure perfect mating and are laser heat treated for superior cutting edge life
- Pliers are Made in USA and forged from high carbon steel that is specially coated for ultimate rust prevention



ANVIL STYLE CUTTING EDGES

319-00358

Ascot No.	Mfg. No.	Length	Weight	Jaw Length	Joint Thickness	Joint Width	Cutter Length
319-00358	358	8" / 203.2mm	.79 Lb. / 358.34 Gr.	.35" / 8.89mm	.49" / 12.45mm	1.63" / 41.4mm	1.18" / 29.97mm

TIRE PROBE AWL

- Used to inspect injuries in tires and to remove small stones and debris

Ascot No.	Mfg. No.	Description
537-00001	AWL-1	Black Handle Awl

537-00001

REMOVES SMALL STONES & DEBRIS



INNERLINER SCRAPER

- This tool is a must for professional tire repairs
- Eliminates power buffing on many tire repairs
- Scraper removes material that might contaminate buffing wheels, ensuring a better repair every time

Ascot No.	Mfg. No.	Description
537-00004	S-4	Black Handle Innerliner Scraper

537-00004

FOR PRO TIRE REPAIRS



BLACK HANDLED TIRE DENAILER

- Recessed tip to allow nails or other puncturing objects to be pushed back through the tire
- MADE IN THE USA

Ascot No.	Mfg. No.	Blade Length	Recess Depth	Point Diameter	Overall Length
537-00353	353	7"	1/8"	5/16"	6-1/2"

537-00353

RECESSED TIP



TIRE REPAIR TOOL POUCH

- Durable nylon pouch
- 3-color tread depth gauge
- 5-50 psi pencil gauge
- Valve core tool
- White crayon
- Ink pen

Ascot No.	Mfg. No.	Description
736-10004	TTP	Tire Repair Tool Pouch

DURABLE NYLON POUCH

736-10004





HANDS-FREE OPERATION

DIMMING SWITCH



312-03007
COB Rechargeable Work Light w/ USB Cable

COB RECHARGEABLE WORK LIGHT W/ USB CABLE

- 400LM brightness
- Dimming Switch
- Features a hook on lamp head and base with magnet for hands-free operation
- **WORKING TIME:** Approx. 2.5 hrs.
- **CHARGING TIME:** Approx. 4 hrs.
- 8W COB LED

Ascot No.	Mfg. No.	Description
312-03007	TWL3007E	COB Rechargeable Work Light w/ USB Cable



312-04146
Tire Service LED Work Light

EXTENDED



312-04147
Replacement Lamp Head for Tire Service LED Work Light

TIRE SERVICE LED WORK LIGHT & REPLACEMENT LAMP HEAD

- **LED:** 1-piece 3W high power LED
- **THREE CONVENIENT SWITCH MODES SO THAT YOU CAN OPERATE AT THE POWER YOU NEED:** High - Low - Off
- **WORKING TIME:** Approx. 3 hours
- **CHARGING TIME:** Approx. 3 hours
- **BRIGHTNESS:** Approx. 200LM for High Mode; 80LM for Low Mode
- Magnet on lamp body and head
- Charging indicator on lamp head
- Detachable lamp head with quick-clip mounting to body
- Smart-clip design for 9mm-32mm distance
- **MULTI-USE:** Clamping, magnetic, hand-held
- **BATTERY:** Customized 3.7V 900mAh rechargeable polymer battery
- **INCLUDED:** 5V 0.6A (UL) adapter + USB cable

Ascot No.	Mfg. No.	Description
312-04146	TWL3035	Tire Service LED Light w/ USB Adapter
312-04147	TWL3035H	Replacement Lamp Head for Tire Service LED Light



312-03120
CREE Head Light with Rechargeable Battery

HEAD LIGHT WITH RECHARGEABLE BATTERY

- Hands-free, versatile and comfortable with adjustable straps
- **MATERIAL:** Aluminum +ABS+PC
- **LED:** 1-piece high power CREE T6 bulb
- **BRIGHTNESS:** Approx. 500LM for high mode
- **4-MODE LED LAMPS:** High - Low - Strobe - off
- **WORKING TIME:** Approx. 6 hours on High; Approx. 12 hours on Low
- **CHARGING TIME:** Approx. 5 hours
- **RECHARGEABLE BATTERIES:** 2x 3.7V 1800mAh Li-ion batteries (3600mAh total battery capacity)
- Sensor Function
- **USB cable included**

Ascot No.	Mfg. No.	Description
312-03120	THL2019	CREE Head Light with Rechargeable Battery

TIRE REPAIR TOOLS & ACCESSORIES



RPG RECHARGEABLE WATERPROOF WORK LIGHT

- 66 LEDs - 600 Lumens
- Waterproof
- Rechargeable battery
- Swivel hook for hanging
- Universal attachment hook can be used as a light stand or attached under car hood

Ascot No.	Mfg. No.	Description
312-05224	CED5224A-AS	RPG Rechargeable Waterproof Work Light
312-15224	CED522P3-AS	Replacement AC Adapter for RPG Rechargeable Waterproof Work Light
312-25224	CED522P1-AS	Replacement 12V Adapter for RPG Rechargeable Waterproof Work Light



312-05224
RPG Rechargeable Waterproof Work Light

312-25224
Replacement 12V Adapter



XLIGHT TIRE SERVICE LED WORK LIGHT

- **CONVENIENT:** Designed for hands-free lighting during tire service and other work applications
- 14" adjustable spring-tube for optimum light positioning within tight spaces
- **BRIGHTNESS:** 2-stage compact high-power LED light provides 125 & 250 lumen output
- Multiple high-power magnets on the handle and light head grip strongly to most metal surfaces
- **RECHARGEABLE**
- **BATTERIES:** Lithium-ion rechargeable battery
- Redesigned handle allows for 25% larger clamping diameter compared with original XLIGHT 14-921
- **CLAMP-ON HANDLE:** Clamp-on handle quickly and easily "grips" over the bead of the tire
- *Compatible with all passenger, light truck and commercial truck tires*
- *Compatible with all tire spreaders*

Ascot No.	Mfg. No.	Description
312-14923	14-923	XLIGHT Tire Service LED Work Light



312-14923
XLIGHT Tire Service LED Work Light

COMPACT & HIGH POWER

HANDS-FREE LIGHTING

LED WORK LIGHT ASSEMBLY

- **LED worklamp for tire spreaders**
- Directional spotlight for increased visibility
- 8W COB LED will provide 650 Lumens, 750 Lux at 1M
- Stays cool to the touch
- Adjustable, flexible gooseneck
- Includes mounting bracket

Ascot No.	Mfg. No.	Description
312-08473	TR8473	LED Work Light Assembly



312-08473
LED Work Light Assembly

SWIVEL HEAD

LED RECHARGEABLE HEADLIGHT

- Material: ABS+Silicone
- LED: COB +3W led
- Battery:1200mAh Li-poly Battery(can be replaced)
- Function: COB high-COB low-3W led high-3W led low-COB flashing
- Press sensor switch, sensing function.
- Brightness: COB:200lumen, 3W led:120lumen
- USB Type-C cable (Included)
- Charging time: 3-4hours
- Working time: 3-8hours
- Waterproof & shockproof

Ascot No.	Mfg. No.	Description
312-39001	CP-H001	LED Rechargeable Head Light



312-39001
LED Rechargeable Head Light

NEW

TIRE SPREADERS & REPAIR STATIONS



MTP, Inc.

HEAVY DUTY TUBELESS TRUCK TUBE/TIRE DUNKERS

- **Space saving design requires 40% less space** • New design fits in left or right corners • Entire rim and tire are checked for air leaks simultaneously • **ONE MAN OPERATION:** Safe and easy to operate, no lifting • **360° TURN IN WATER:** Easy and fast inspection
- Uni-quick ratchet type adapter adjusts from 15" dia. to 52" dia. and instantly lifts up to 400 lb. RVs to super singles
- Optional inner tube adapter allows you to check tubes up to 50" in diameter



517-00039



517-00055



Ascot No.	Mfg. No.	Description
517-00100	100TTD	E-Z Dunk Truck Tire Dunker, Range 15" - 50" Diameter
517-00039	39ED	39" Dia. x 24" Depth Passenger & RV Tube & Tire Dunker with Polyethylene Tank
517-00055	55T	T & G 55" Dia. x 24" Depth Truck & Grader Tube Dunker with Polyethylene Tank

EZ-110D TRUCK TIRE DUNKER W/ LIFT

- **One man operation** • Picks up tire in and out of water • Adapter for 8 - 10 hole wheels • 55" x 24" Poly tub • *Optional Inner tube/ tire spider available* • Submerges entire tire under water • Can rotate under water for easy marking



517-11033

Ascot No.	Mfg. No.	Description
517-11033	EZ-110D	EZ-110D Truck Tire Dunker w/Lift

Branick

ALL PURPOSE "EF" FULL CIRCLE TIRE SPREADER

- **Expose tire defects immediately!**
- Bead Diameter minimum 13.5", maximum 25.5" • Cross Sections minimum 5", maximum 21.5" • Revolve the tire 360° for inspection, repair and buffing or installing tubes, flaps and air bags inside curing rims • Maximum operating pressure of 150 PSI • Air-operated lift raises tire to inspection position



602-60210

Ascot No.	Mfg. No.	Description
602-60210	eF	All Purpose Full Circle Tire Spreader

TIRE SPREADERS & REPAIR STATIONS



Branick

HEAVY DUTY “EF/HD” FULL CIRCLE TIRE SPREADER

- Designed to lift and spread truck, bus, tractor and some aircraft tires 14” thru 24”, 20-ply, including steel radial tires • Revolves 360°, while spread, for easy excellent inspection • Conveniently located floor-mount controls
- Diameter arms easily slide into position to hold inner beads before spreading

HEAVY DUTY

REVOLVES THE TIRE 360°



602-60211



TIRE SPREADER FOR RETREADERS & COMMERCIAL FACILITIES

- Versatile machine with twice the lift height of the previous model • This model has a smaller dimensional footprint • Will handle tires 20% wider than the previous model • 33% greater Lifting Capacity • Handles tires sizes from Passenger, Truck, Tractor & small OTR • New tilt function for operator comfort

SMALL FOOTPRINT

NEW TILT FUNCTION



603-03000

Ascot No.	Mfg. No.	Description
602-60211	eF-HD	Heavy Duty Full Circle Tire Spreader

Ascot No.	Mfg. No.	Description
603-03000	RHS-300	Tire Spreader for Retreaders & Commercial Facilities

Branick

PASSENGER/LIGHT TRUCK TIRE SPREADER

- Handles passenger and light truck tires up to 20"
- Controlled tension release to avoid snap-back on tough sidewalls
- Easily rotate the tire to locate the repair point
- Quick and easy spread of tire and reduced footprint



604-05045

Ascot No.	Mfg. No.	Description
604-05045	5045	Passenger/Light Truck Tire Spreader

Branick

INVERTING TIRE SPREADER/REPAIR STATION

- Spreads and inverts passenger, truck and bus tires with ease for inspection and repair
- Foot control valve conveniently located at base of machine
- Adjustable lamp swings in and out of tire



604-05120

Ascot No.	Mfg. No.	Description
604-05120	5120	Inverting Tire Spreader/Repair Station

Branick

PASSENGER, LIGHT TRUCK AND COMMERCIAL TRUCK TIRE SPREADER

- Handles everything from passenger to super-single truck tires
- Adjustable height and a tire ramp
- Lifts 35" off the ground
- Manual rotation with a tool tray that swivels left and right
- Controls for the lift are on both sides of the unit



604-05500

Ascot No.	Mfg. No.	Description
604-05500	5500	Passenger, Light Truck and Commercial Tire Spreader

AUTOMATIC TRUCK TIRE SPREADER

- Air lift allows operator to lift without lifting the tire/wheel
- Heavy gauge steel construction
- Work light included • Air regulator/lubricator included

HEAVY GAUGE STEEL DESIGN



The Automatic Truck Tire Spreader in use.



603-00825

Ascot No.	Mfg. No.	Description
603-00825	BJ-S825	Automatic Truck Tire Spreader

Ascot No.	MFG. NO.	Description
AUTOMATIC TRUCK TIRE SPREADER PARTS & ACCESSORIES		
603-82501	658	Handle Valve for Automatic Truck Tire Spreader
603-82502	650	Air Regulator for Automatic Truck Tire Spreader
603-82503	711	O-Ring for Automatic Truck Tire Spreader
603-82504	712	Washer for Automatic Truck Tire Spreader
603-82505	715	Dustproof Seal for Automatic Truck Tire Spreader
603-82506	720	Right Angle Connector for Automatic Truck Tire Spreader
603-82507	728	Middle Union for Automatic Truck Tire Spreader
603-82508	730	Middle Union for Automatic Truck Tire Spreader
603-82509	733	Straight Union for Automatic Truck Tire Spreader
603-82510	736	Rubber O-Ring for Automatic Truck Tire Spreader
603-82511	737	Oil-Free Piston for Automatic Truck Tire Spreader

TIRE SPREADERS & REPAIR STATIONS



TIRE SPREADER

- Simple tool designed to quickly make tire repairs easy • Ideal for mobile service

IDEAL FOR MOBILE SERVICE



605-00101

Ascot No.	Mfg. No.	Description
605-00101	GTS-01	Tire Spreader

MANUAL TIRE SPREADER

- Lightweight and easy to use • Special locking pin for safety • Made from durable materials • Locks both beads open for easy tire inspection and repair

LIGHT-WEIGHT AND EASY

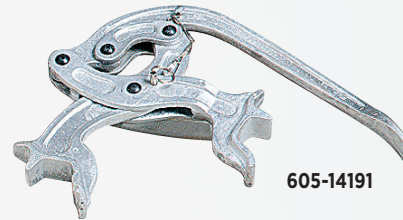

605-14191

Ascot No.	Mfg. No.	Description
605-14191	MS-1	Manual Tire Spreader

MANUAL TIRE SPREADERS

- For large truck tires • Used in pairs • Spreads tires up to 17" span • Spreading power of a car jack • Heavy duty construction • Weight: 4-1/4 Lbs.

FOR LARGE TRUCK TIRES



605-31554

Ascot No.	Mfg. No.	Description
605-31554	T54	Manual Tire Spreader

ALPHABETICAL INDEX

A//

Adjusting Tools _____ 201
 Air Chucks - Ball Foot _____ 168
 Air Chucks - Clip On _____ 167
 Air Chucks - Dual Foot _____ 167
 Air Chucks - European Style _____ 168, 169
 Air Chucks - Large Bore _____ 170
 Air Chucks - Lock-On _____ 168, 169
 Air Chucks - Reverse Chuck _____ 167
 Air Compressor - Gas Engine _____ 13
 Air Compressor - Simplex _____ 13
 Air Compressor Maintenance Parts _____ 13
 Air Compressors _____ 6-11
 Air Cooler Tester _____ 230
 Air Drills _____ 24
 Air Drills - Accessories _____ 24
 Air Dryers - Refrigerated _____ 12
 Air Hoses _____ 16
 Air Line Couplers & Plugs _____ 17, 18
 Alignment Set _____ 197
 Alignment Systems _____ 200

B//

Balancing Beads - Counteract _____ 192
 Balancing Beads - Eco _____ 192
 Balancing Compound _____ 193
 Battery Starters _____ 202
 Bead Bazooka _____ 124
 Bead Bazooka Replacement Parts _____ 124
 Bead Booster _____ 121, 127
 Bead Breaker - Slide Hammer _____ 119
 Bead Breakers - AME _____ 115-118
 Bead Breakers - Esco _____ 115-119
 Bead Breakers - Floor Type _____ 118
 Bead Breakers - Gaither Pneumatic _____ 115
 Bead Breakers - Impact _____ 119
 Bead Breakers - Portable _____ 118
 Bead Breaking Wedges _____ 137
 Bead Expanders _____ 126
 Bead Holder _____ 130, 132
 Bead Keepers _____ 127
 Bead Lock _____ 130
 Bead Saver System _____ 126
 Bead Sealers _____ 232, 237, 238
 Bead Sealer - Rim _____ 237
 Bead Seater - Jet Pak _____ 125
 Bead Seater Accessories _____ 120
 Bead Seater Accessories - Cheetah _____ 123
 Bead Seaters - Cheetah _____ 122
 Bead Seaters - Esco _____ 123
 Bead Seaters - RPG _____ 120
 Bead Seaters - Viper _____ 121

B//

Bead Seating Stands _____ 125
 Blow Gun Kit _____ 16
 Blue Tork Accessories _____ 41
 Blue Tork Non-Impact Wrench _____ 27
 Bottle Jacks - AFF _____ 67
 Bottle Jacks - AME _____ 66
 Bottle Jacks - Ascot _____ 70
 Bottle Jacks - Esco _____ 68
 Bottle Jacks - Norco _____ 62
 Bottle Jacks - Omega Lift _____ 63
 Bottle Jacks - RPG _____ 65
 Bottle Jacks - Winntec _____ 64
 Bottle Jacks - Zinco _____ 64
 Brake Drum Handlers _____ 102
 Brake Drum Mounting Hardware _____ 51
 Brushes - Cleaning _____ 104, 205
 Brushes - Power _____ 60
 Buffing Stones _____ 249
 Buffing Wheels _____ 249
 Buffout Wheels _____ 247

C//

Cabinets _____ 237, 240
 Cements _____ 232, 237, 238
 Centering Sleeve Installation/Removal Tool _____ 46
 Centering Sleeves _____ 46, 47
 Chloride Pumps _____ 128, 129
 Chloride Pumps - Replacement Parts _____ 129
 Chuck Adapters/Accessories _____ 243
 Clamp Service Kits _____ 19
 Clamps - 2 Ear _____ 19
 Clamps - Pinch _____ 19
 Cleaner - Pre-Buff _____ 236
 Clutch Adjusting Wrench _____ 103
 Code Reader Kit _____ 225
 Cone Wheel Nuts _____ 51
 Contour Wheels _____ 248
 Cut Off Wheels _____ 146
 Cut-Off Tools _____ 24
 Cutting Tools - Carbide _____ 249

D//

Demounter - Impact Driven _____ 119
 Diagnostic Tools _____ 223, 224
 Die Grinder Kit _____ 146
 Die Grinders - 1/4" Mini Angle _____ 23
 Drains - Oil _____ 211-214
 Driveway Signal _____ 217
 Drum Packages _____ 230
 Dual Wheel Extensions _____ 158
 Dual Wheel Separators _____ 141

E//

Ear Muffs _____ 216
 Ear Plugs _____ 216
 Eco Seal _____ 111
 Engine Stand - Diesel _____ 103
 Equal Flexx _____ 194
 Extender Bars _____ 200
 Eye Wash Stations _____ 217

F//

Face Shields _____ 216
 Filter Cleaners _____ 226
 Filters - General Purpose _____ 15
 Floor Mats - Paper _____ 209
 Floor Mats - Plastic _____ 208
 Floor Racks - Display _____ 210
 Fluid Exchanger _____ 229
 Flushers _____ 229
 Forklift Jacks _____ 93, 94

G//

Gauge - Radial Runout _____ 201
 Gauge Checking Stations _____ 166
 Gauges - Adjustable Truck _____ 165
 Gauges - Brake Lining Thickness _____ 163
 Gauges - Digital _____ 164
 Gauges - Dual Foot _____ 167
 Gauges - Large Bore _____ 170
 Gauges - Master Test _____ 165
 Gauges - Tread Depth _____ 163
 Gauges - Truck Service _____ 163
 Gloves - Leather Double Palm _____ 222
 Gloves - Mechanic _____ 221
 Gloves - Misc _____ 222
 Gloves - Nitrile Black _____ 221
 Gloves - Nitrile Diamond _____ 221
 Gloves - Work _____ 222

H//

Hammer Handles - Fiberglass _____ 136, 137
 Hammer Handles - Hickory _____ 137
 Hammers - Fiberglass _____ 137
 Hammers - Heavy Duty _____ 136
 Hammers - Wooden _____ 136
 Hand Cleaners & Dispensers _____ 206
 Handle Protectors _____ 73
 Hex Nut Removers _____ 55
 Hose Fittings _____ 20
 Hose Reels _____ 16
 Hose Reels - Heavy Duty _____ 17
 Hub Buddy Tool _____ 59
 Hub Caps - Oil Seal _____ 51

ALPHABETICAL INDEX (CONT.)

H//

Hub Centric Nut	54
Hub Cover Installation Tool	50
Hydraulic Pump	119

I//

Impact Socket Sets	34, 35
Impact Sockets - Individual	36, 37
Impact Wrench Accessories	32
Impact Wrench Replacement Parts	21
Impact Wrenches - #5 Spline Drive	21, 31
Impact Wrenches - 1" Drive	21, 31, 26, 27,
Impact Wrenches - 1" Drive D-Handle	29, 31
Impact Wrenches - 1/2" Drive	22, 25, 30
Impact Wrenches - 1/2" Drive Cordless	28
Impact Wrenches - 3/4" Drive	22, 26, 30
Impact Wrenches - 3/4" Drive D-Handle	26
Industry Standard Truck Kit	231
Inflation Cages - Accessories	150
Inflation Cages - Safety	147-149
Inflation Systems	14, 142, 143
Inflators - Air Line	174
Inflators - Automatic	171
Inflators - Digital	172
Inflators - Heavy Duty	173
Inflators - Large Bore	174
Inner Cap Nuts	50
Inner Liner Sealers	238
Insert Kits	239
Insertion Tools	239
Installer - Bearing Cup	227

J//

Jack Oil - Hydraulic	103
Jack Plates	69
Jack Stands - Omega Lift	85
Jack Stands - AME	86
Jack Stands - Esco	83
Jack Stands - Hein-Werner	84, 86
Jack Stands - Norco	83, 85
Jack Stands - Omega Lift	83
Jack Stands - RPG	81
Jack Stands - Winntec	82
Jacks - High Tonnage	80
Jacks - Two Stage Hydraulic	77

K//

Key Tags - Paper	208
Key Tags - Plastic	209
Knee Pads	217
Knives - Misc	245
Knives - Rubber	245

K//

Knives - Skiving	245
Knives - Tire Repair	245

L//

Leak Detector	109
Lift Jacks	91-93
Lifts - Heavy Duty	179
LiquiTube	110
Lock Nut Sockets - Wheel Bearing	227
Lock Ring Remover	135
Locking Back Nuts	51
Loose Nut Indicators - Check Point	43, 44
Loose Nut Indicators - Kentool	45
Loose Nut Prevention Tools	45
Lubricants	33, 105, 106
Lubricants - Liquid	107
Lubricating Compound - Anti Seize	110
Lubricators	15
Lug Nut Pullers	49
Lug Nut Removers	48
Lug Nut Remover Sockets	49
Lug Wrenches	139

M//

Manifold Hose Kit	230
Marker Holder	112
Markers	112
Mini Ductor Replacement Parts	220
Mini Ductors	219, 220
Mount/Demount Tools	126, 130, 131, 132
Mounting/Packing Compound	107
Mud Flap Bolt Kit	51

N//

No Rim Rust	106
Nut Gauge - Chamfer	57
Nut Splitters	155

O//

O-Rings	154
Oil Accessories	215
Oil Filter Crusher	215
Outer Cap Nuts	50

P//

Patches	238
Patches - Bias Ply	236
Patches - Bias Repairs	233
Patches - Combi	231, 235
Patches - Radial Repairs	231, 233, 234
Patches - Universal	235

P//

Patches - Stem Inserts	234
Penetrant - Blaster	110
Plastic Bag - Parts Return	208
Pliers	204, 250
Pumps - Poly	213
Pumps - Steel	213

R//

RAR Valve Upgrade Kits	125
Rasps - Contour Cup	246
Rasps - Copper Contour Wheels	246
Rasps - Slotted Finishing	246
Recycling Systems	228
Refractometer	225
Refrigerant Charging Scale	230
Refrigerant Systems	228
Regrooving Tools & Accessories	113
Regulators	15
Rethreaders	48
Rib Nut Salvager Tool Kit	55
Rib Nuts - Replacement	56
Rib-Grip Lug-Off Kits	56
Rim Clamps - GL	52
Rim Clamps - Sirco	52
Rim Cleaners - Inner	58
Rim Flange Wear Gauge	57
Rim Gauges	190
Rim Kote	106
Rim Rust Release	108

S//

Safety Glasses	216
Scan Tool	225
Sealants	232
Sealants - STS	111
Serial Number Remover	113
Service Jacks - AFF	72
Service Jacks - AME	71, 79
Service Jacks - Ascot	70
Service Jacks - Blackhawk	73
Service Jacks - Gaither	73, 78
Service Jacks - Hein-Werner	71, 78, 79
Service Jacks - Norco	71, 72, 74
Service Jacks - Omega Lift	72, 79
Service Jacks - Winntec	71
Service Jacks - Yak	75, 76
Service Jacks - Zinko	72
Service Stickers & Printers	207
Shims - Adjusting	198
Shims - Air Glide	198
Shims - Alignment	196
Shims - Axle	197

ALPHABETICAL INDEX (CONT.)

S//

Shims - Flex Air Suspension _____ 198
 Shims - Hendrickson _____ 199
 Shims - Tandem _____ 198
 Shims - Torque Arm _____ 198
 Shop Press Accessories _____ 100
 Shop Presses _____ 100
 Skirt Nuts _____ 53, 54
 Slick _____ 105
 Spacer - Air Glide _____ 197
 Spoke Wheel Hardware _____ 51
 Sprayers _____ 109
 Squeegees _____ 205
 Steering Wheel Cover _____ 209
 STS Tools _____ 111
 Stud Adapters _____ 56
 Stud Cleaning Kit _____ 59
 Stud Cleaning Tools _____ 58
 Stud Hub Brush Kit _____ 59
 Stud Installers _____ 56
 Stud Removers _____ 56
 Super Slick'em _____ 126
 Sur-Lock Valve Tools _____ 161
 Surface Conditioning Discs _____ 145, 146

T//

Tandem Axle Caliper _____ 199
 Tandem Tracker Set _____ 199
 Tape - Dot Conspicuity _____ 217
 Thermometer - Infrared _____ 230
 Thread Pitch Gauge _____ 57
 Tire Branders Letters & Numbers - 1" _____ 114
 Tire Branders Letters & Numbers - 1/2" _____ 114
 Tire Branders Letters & Numbers - 1/4" _____ 114
 Tire Buffers - Heavy Duty _____ 241
 Tire Buffers - High Speed _____ 23, 27, 241, 242
 Tire Buffers - Low Speed _____ 23, 27, 31, 241, 242
 Tire Changers - Heavy Duty _____ 175-177
 Tire Changing Stand _____ 150
 Tire Dunkers _____ 253
 Tire Inflators _____ 144
 Tire Iron - Tubeless _____ 135
 Tire Knocker _____ 137
 Tire Labels _____ 208, 209
 Tire Lifter _____ 98
 Tire Mating Square _____ 199
 Tire Mounting Compound _____ 105, 106, 108
 Tire Mounting Liquid _____ 108
 Tire Mounting Paste _____ 106, 107
 Tire Probes & Needles _____ 244
 Tire Repair Kits _____ 239
 Tire Repair Tools _____ 250
 Tire Spoons _____ 133

T//

Tire Spreader Accessories _____ 256
 Tire Spreaders _____ 253-256
 Tire Swabs _____ 104
 Toe Bars _____ 199, 201
 Tool Pouch _____ 250
 Torque Extension - Truck _____ 38
 Torque Limiting Extensions _____ 41
 Torque Multiplier - Pneumatic _____ 42
 Torque Sockets _____ 38, 41
 Torque Wrench - Accessories _____ 38
 Torque Wrench - Industrial _____ 42
 Torque Wrench Checker _____ 42
 Torque Wrenches - 1/2" Drive 5-In-1 Preset _____ 40
 Torque Wrenches - 1" Preset _____ 40
 Torque Wrenches - 1/2" Drive _____ 40
 Torque Wrenches - 5/8" Preset _____ 38
 Torque Wrenches - 9/16" Preset _____ 38
 Torque Wrenches - Battery Powered _____ 41
 Torque Wrenches - Flex Hinge Style _____ 40
 Torque Wrenches - Micrometer _____ 39
 Torque Wrenches - Split Beam _____ 39
 TPMS Systems _____ 151
 Trailer Tester _____ 227
 Transmission Jack - Hein-Werner _____ 88
 Transmission Jack - Norco _____ 87
 Transmission Jack - Telescopic _____ 89
 Transmission Jack Adapters _____ 88, 90
 Truck Clutch - Flywheel Handler _____ 103
 Truck Ramps _____ 90
 Truck Slip Plate Set _____ 199
 Truck Wrenches - Double End _____ 140

V//

Vacuum - Tire Repair _____ 243
 Valve Adapter Gun _____ 128
 Valve Adapter Gun Accessories _____ 128
 Valve Breakers _____ 155
 Valve Caps _____ 158
 Valve Core Tools _____ 162
 Valve Extensions _____ 159, 160
 Valve Insertion & Removal Tools _____ 161
 Valve Stem Removal _____ 155
 Valve Stem Wrenches _____ 155
 Valve Tool Kit _____ 157
 Valve Tools - Standard Bore _____ 161
 Valves - Tire Tubeless _____ 152
 Valves - Truck _____ 153
 Vests - Safety _____ 217
 Vises _____ 203

W//

Wheel & Rim Removal Tool _____ 141
 Wheel Balancers _____ 178
 Wheel Breaker Set _____ 119
 Wheel Chocks _____ 218
 Wheel Dollies _____ 96, 97
 Wheel Dollies - 3/4-Ton _____ 98
 Wheel Dollies - Hydraulic _____ 95
 Wheel Hub Cleaners _____ 58
 Wheel Hub Grinders _____ 58
 Wheel Installation Sleeves _____ 57
 Wheel Lug Stud Remover _____ 140
 Wheel Nut Retainers _____ 45
 Wheel Pans _____ 214
 Wheel Protectors _____ 52, 132
 Wheel Rim Guard _____ 52
 Wheel Rim Straightening Tool _____ 201
 Wheel Stud Alignment Tool _____ 47
 Wheel Stud Installers _____ 56
 Wheel Stud Remover/Installer _____ 48
 Wheel Stud Service Kit _____ 57
 Wheel Weight Hammers _____ 189, 190
 Wheel Weight Racks _____ 188
 Wheel Weight Removal Tools _____ 189
 Wheel Weight Roll Stands _____ 188
 Wheel Weight Rolls - Adhesive _____ 187
 Wheel Weight Scrapers _____ 190
 Wheel Weights - Adhesive _____ 183-186
 Wheel Weights - CT Series _____ 180
 Wheel Weights - CTZ Type _____ 181
 Wheel Weights - I7 Series _____ 181
 Wheel Weights - I7Z Type _____ 181
 Wheel Weights - LT1 Series _____ 180
 Wheel Weights - LT1Z Type _____ 182
 Wheel Weights - RC Series _____ 180
 Wheel Weights - RCZ Type _____ 182
 Wheel Weights - TAL Series _____ 181
 Wheel Weights - TALZ Type _____ 182
 Wheel Weights - TS Series _____ 180
 Wheelok Systems _____ 55
 Wipes _____ 205
 Wire Wheels _____ 60
 Work Lights _____ 251, 252
 Work Stations _____ 24
 Wrenches - Heavy Duty Truck _____ 140
 Wrenches - 5/8" Preset _____ 156
 Wrenches - 9/16" Preset _____ 156
 Wrenches - Nut _____ 138
 Wrenches - Porkchop _____ 138
 Wrenches - Valve Nut _____ 156

NUMERIC INDEX BY PART NO.

101-00058 _____	6	104-07101 _____	11	112-00378 _____	15	132-61554 _____	18	154-02616 _____	30
101-00078 _____	6	104-07121 _____	11	112-01352 _____	15	132-61558 _____	18	154-10261 _____	22
101-00158 _____	6	105-00015 _____	12	112-01354 _____	15	132-61559 _____	18	154-21617 _____	30
101-01012 _____	6	105-00025 _____	12	112-03910 _____	15	133-01855 _____	18	154-27763 _____	26
101-10325 _____	7	105-00035 _____	12	112-03912 _____	15	133-61471 _____	18	154-37763 _____	26
101-11012 _____	6	105-00050 _____	12	113-01352 _____	15	133-61474 _____	18	155-00280 _____	31
101-11153 _____	10	105-00075 _____	12	113-01354 _____	15	133-61563 _____	18	155-00295 _____	31
101-15203 _____	10	105-00100 _____	12	117-05050 _____	13	133-61564 _____	18	155-02806 _____	31
101-18253 _____	10	105-00125 _____	12	117-05051 _____	13	133-61568 _____	18	155-02850 _____	31
101-22303 _____	10	105-00150 _____	12	117-58625 _____	41	133-61569 _____	18	155-02856 _____	31
101-23303 _____	10	105-00425 _____	10	119-00130 _____	14	136-00344 _____	20	155-07773 _____	26
101-26353 _____	10	105-00535 _____	10	119-00485 _____	14	136-00366 _____	20	155-07778 _____	27
101-29403 _____	10	105-00750 _____	10	119-00500 _____	14	136-00401 _____	20	155-07782 _____	26
101-40780 _____	6	105-01175 _____	10	121-01225 _____	16	136-00406 _____	20	155-07971 _____	27
101-40781 _____	6	105-01590 _____	10	121-01250 _____	16	136-00408 _____	20	155-07976 _____	27
101-40782 _____	6	105-18125 _____	10	121-03825 _____	16	136-00604 _____	20	155-12856 _____	21
101-40783 _____	6	105-22150 _____	10	121-03851 _____	16	136-00606 _____	20	155-17782 _____	26
101-41012 _____	6	106-00519 _____	13	121-14700 _____	16	136-00608 _____	20	155-17786 _____	21
101-41112 _____	6	106-11727 _____	13	121-56323 _____	16	136-00806 _____	20	155-26464 _____	21
101-41512 _____	6	106-11728 _____	13	121-56324 _____	16	136-00808 _____	20	155-27786 _____	27
101-42112 _____	6	106-11729 _____	13	124-07450 _____	17	136-01344 _____	20	155-28506 _____	31
101-42512 _____	6	106-11730 _____	13	125-00760 _____	16	136-01366 _____	20	155-28560 _____	31
101-43512 _____	6	106-11882 _____	13	125-07650 _____	17	136-02344 _____	20	155-77736 _____	26
101-44112 _____	6	106-11883 _____	13	125-07651 _____	17	136-02366 _____	20	155-77786 _____	27
101-44512 _____	6	106-11884 _____	13	125-07652 _____	17	136-34490 _____	20	155-77826 _____	26
101-45231 _____	10	106-13194 _____	13	125-07670 _____	17	136-71404 _____	20	155-86720 _____	28
101-50080 _____	13	106-28530 _____	13	126-00761 _____	16	136-71504 _____	20	155-86722 _____	28
101-51120 _____	7	106-37831 _____	7	126-07850 _____	17	136-71604 _____	20	155-86820 _____	29
101-53120 _____	7	106-37832 _____	7	126-07851 _____	17	136-71606 _____	20	155-86822 _____	29
101-54120 _____	7	106-89090 _____	13	128-00006 _____	16	136-71806 _____	20	155-86920 _____	29
101-57523 _____	10	106-94730 _____	13	131-08888 _____	17	136-71808 _____	20	155-86922 _____	29
101-71023 _____	10	111-30002 _____	15	131-61486 _____	17	136-72404 _____	20	156-02951 _____	31
101-73904 _____	8	111-32908 _____	15	131-61523 _____	18	153-00231 _____	30	156-12856 _____	21
101-75080 _____	13	111-35200 _____	15	131-61524 _____	18	153-00736 _____	25	156-17786 _____	21
101-75120 _____	7	111-35201 _____	15	131-61526 _____	17	153-02235 _____	30	156-28006 _____	31
101-75320 _____	7	111-35202 _____	15	131-61527 _____	17	153-02312 _____	30	156-28566 _____	31
101-75420 _____	7	111-35203 _____	15	131-61528 _____	17	153-07336 _____	25	156-79716 _____	27
102-11530 _____	7	111-35300 _____	15	131-61529 _____	17	153-07492 _____	25	157-01035 _____	24
102-11560 _____	7	111-35301 _____	15	131-61538 _____	18	153-07749 _____	25	157-01327 _____	31, 242
102-11880 _____	7	111-35302 _____	15	131-61539 _____	18	153-12131 _____	22	157-01875 _____	146
102-13030 _____	13	111-35303 _____	15	131-61548 _____	17	153-12235 _____	30	157-04038 _____	241
102-13730 _____	7	111-35400 _____	15	131-61550 _____	17	153-12260 _____	22	157-06010 _____	241
102-13760 _____	7	111-35401 _____	15	131-61551 _____	17	153-17492 _____	25	157-06510 _____	241
102-13780 _____	7	111-35402 _____	15	131-61573 _____	18	153-22131 _____	22	157-06520 _____	242
104-01201 _____	11	111-35403 _____	15	131-61574 _____	18	153-22235 _____	30	157-06550 _____	241
104-01202 _____	11	111-37600 _____	15	131-61578 _____	18	153-32235 _____	30	157-10874 _____	24
104-04120 _____	11	111-37601 _____	15	131-61579 _____	18	153-76920 _____	28	157-10875 _____	23
104-04501 _____	11	112-00162 _____	15	131-62523 _____	18	153-76922 _____	28	157-14038 _____	241
104-04502 _____	11	112-00262 _____	15	132-61476 _____	18	153-77492 _____	25	157-16010 _____	241
104-04503 _____	11	112-00352 _____	15	132-61478 _____	18	154-00261 _____	30	157-16510 _____	241
104-05127 _____	11	112-00353 _____	15	132-61480 _____	18	154-00772 _____	26	157-16520 _____	242
104-05750 _____	11	112-00354 _____	15	132-61481 _____	18	154-01772 _____	26	157-16550 _____	241
104-05751 _____	11	112-00376 _____	15	132-61553 _____	18	154-02613 _____	30	158-00871 _____	27, 242

NUMERIC INDEX (CONT.)

158-00873	27, 242	163-10261	36	165-05626	35	168-12250	40	173-09214	243
158-01871	27	163-10270	36	165-30300	37	168-12997	38	173-09215	243
158-01873	27	163-10271	36	165-30301	37	168-12999	38	173-09216	243
158-02871	27	163-10280	36	165-30302	37	168-18141	42	173-09400	243
158-10871	23, 242	163-10281	36	165-30361	37	168-29706	156	175-01035	24
158-10873	23, 241	163-10282	36	165-30362	37	168-29707	156	175-01590	32
158-11871	23, 241	163-10283	36	165-30380	37	168-29731	156	175-10026	21
163-01018	36	163-10300	36	165-30381	37	168-29732	156	175-10037	21
163-01019	36	163-10360	36	165-30401	37	168-29756	156	175-10040	21
163-01021	36	163-10401	36	165-30402	37	168-29757	156	175-10043	21
163-01022	36	163-11032	36	165-30410	37	168-42760	42	175-11035	24
163-01024	36	163-15260	36	165-30420	37	168-42761	42	175-23142	32
163-01026	36	163-22219	34	165-30481	37	168-43237	42	175-31425	32
163-01030	36	164-02017	36	165-30482	37	168-47501	40	175-33104	32
163-01032	36	164-02021	36	166-04026	37	168-57600	42	175-81426	32
163-01033	36	164-02024	36	166-04033	37	168-57601	42	175-82651	32
163-01034	36	164-02026	36	166-04034	37	168-60011	40	175-83071	32
163-01036	36	164-02030	36	166-04035	37	168-60012	40	175-91425	32
163-01048	36	164-02033	36	166-04038	37	168-67250	38	176-10212	32
163-01150	34	164-02034	36	166-04040	37	168-67505	41	176-10221	32
163-01151	34	164-02038	37	166-04041	37	168-80246	40	176-10244	32
163-01152	34	164-02042	37	166-04042	37	168-97354	39	176-10261	32
163-01153	34	164-02046	37	166-04048	37	169-01002	37	176-10280	32
163-02668	34	164-02056	37	166-04191	35	169-01003	37	176-10285	32
163-02669	34	164-02110	34	166-04323	37	169-01005	37	176-12313	32
163-05153	34	164-02181	34	166-40480	37	169-01020	37	176-13532	32
163-10111	36	164-02323	37	167-12030	35	169-01234	35	176-17803	32
163-10130	36	164-20301	37	167-12050	35	169-02006	37	176-18406	21
163-10131	36	164-20330	37	167-12051	35	169-02010	37	176-20232	32
163-10142	36	164-20401	37	167-12110	36	169-02013	37	176-21132	32
163-10143	36	164-20480	37	167-12179	36	169-02030	37	176-21350	32
163-10161	36	164-20481	37	167-12460	36	169-03006	37	176-22235	32
163-10162	36	165-03017	37	167-12461	36	169-03010	37	176-23122	32
163-10170	36	165-03019	37	167-12490	36	169-03013	37	176-24432	32
163-10171	36	165-03021	37	167-12910	36	169-03020	37	176-25925	32
163-10172	36	165-03026	37	167-12911	36	169-04010	37	176-26132	32
163-10174	36	165-03030	37	167-12912	36	169-04020	37	176-28532	32
163-10180	36	165-03033	37	167-18195	36	169-13413	38	176-32135	32
163-10182	36	165-03034	37	167-21215	36	169-20100	37	181-00016	33
163-10183	36	165-03035	37	167-21225	36	173-00018	243	181-00080	33
163-10190	36	165-03041	37	167-22225	36	173-00019	243	181-00085	33
163-10191	36	165-03042	37	168-00058	38, 156	173-00020	243	181-00404	33
163-10200	36	165-03046	37	168-00475	38	173-00022	243	181-00406	33
163-10201	36	165-03052	37	168-00916	38, 156	173-00023	243	181-01404	33
163-10210	36	165-03054	37	168-02100	39	173-09150	243	181-10510	32
163-10211	36	165-03056	37	168-03250	39	173-09165	243	181-10540	32
163-10220	36	165-03060	37	168-03251	39	173-09166	243	181-11510	32
163-10221	36	165-03110	34	168-04400	39	173-09167	243	181-11540	32
163-10222	36	165-03119	35	168-05600	39	173-09201	243	181-12228	32
163-10223	36	165-03190	35	168-07600	27	173-09202	243	228-61400	201
163-10223	36	165-03197	35	168-07602	27	173-09211	243	241-04050	197
163-10230	36	165-03321	37	168-07603	27	173-09212	243	241-04051	197
163-10240	36	165-03323	37	168-11126	156	173-09213	243	241-05050	197

NUMERIC INDEX (CONT.)

241-05051 _____	197	241-10731 _____	197	246-35062 _____	198	301-10383 _____	68	302-22050 _____	79
241-06050 _____	197	241-10740 _____	197	246-35070 _____	198	301-10500 _____	63	302-22051 _____	79
241-06051 _____	197	241-10741 _____	197	246-35071 _____	198	301-14455 _____	66	302-22100 _____	79
241-07050 _____	197	241-10750 _____	197	246-35072 _____	198	301-14460 _____	66	302-22101 _____	79
241-07051 _____	197	241-10751 _____	197	246-36000 _____	197	301-14461 _____	66	302-22201 _____	79
241-10410 _____	197	241-10760 _____	197	246-36010 _____	198	301-14475 _____	66	302-23221 _____	72
241-10411 _____	197	241-10761 _____	197	246-36011 _____	198	301-14480 _____	66	302-28045 _____	94
241-10420 _____	197	241-10770 _____	197	246-36012 _____	198	301-18126 _____	63	302-31500 _____	82
241-10421 _____	197	241-10771 _____	197	246-43415 _____	196	301-18204 _____	63	302-31501 _____	82
241-10430 _____	197	241-10781 _____	197	246-43416 _____	196	301-18206 _____	63	302-32035 _____	83
241-10431 _____	197	241-35001 _____	197	246-43417 _____	196	301-18209 _____	63	302-32065 _____	83
241-10440 _____	197	241-35002 _____	197	246-43441 _____	196	301-18302 _____	63	302-32066 _____	85
241-10441 _____	197	241-35003 _____	197	246-43442 _____	196	301-18502 _____	63	302-32075 _____	83
241-10450 _____	197	241-35004 _____	197	246-43443 _____	196	301-18992 _____	63	302-32105 _____	83
241-10451 _____	197	241-35005 _____	197	246-43447 _____	196	301-20220 _____	70	302-32107 _____	83
241-10460 _____	197	241-35006 _____	197	246-43548 _____	196	301-20221 _____	70	302-32125 _____	83
241-10461 _____	197	241-35007 _____	197	246-43549 _____	196	301-41020 _____	64	302-32126 _____	85
241-10470 _____	197	241-36080 _____	199	246-43550 _____	196	301-41040 _____	64	302-32225 _____	83
241-10471 _____	197	241-36085 _____	199	246-43551 _____	196	301-41060 _____	64	302-33020 _____	82
241-10510 _____	197	241-36087 _____	199	246-43552 _____	196	301-41080 _____	64	302-43202 _____	71
241-10511 _____	197	243-00841 _____	197	246-43553 _____	196	301-41150 _____	64	302-43222 _____	73
241-10520 _____	197	243-00842 _____	197	246-43554 _____	196	301-41200 _____	64	302-45125 _____	82
241-10521 _____	197	243-00843 _____	197	246-51100 _____	199	301-41201 _____	64	302-51005 _____	81
241-10530 _____	197	243-00844 _____	197	247-08130 _____	201	301-41300 _____	64	302-56501 _____	72
241-10531 _____	197	243-00845 _____	197	247-18410 _____	199	301-43220 _____	64	302-63030 _____	81
241-10540 _____	197	243-00846 _____	197	247-18440 _____	199	301-61120 _____	65	302-63060 _____	81
241-10541 _____	197	243-00847 _____	197	247-33173 _____	201	301-61124 _____	65	302-63120 _____	81
241-10550 _____	197	243-00848 _____	197	247-51200 _____	199	301-61200 _____	65	302-63220 _____	81
241-10551 _____	197	243-00891 _____	197	247-91860 _____	200	301-76312 _____	62	302-63221 _____	81
241-10560 _____	197	243-00892 _____	197	247-91877 _____	200	301-76320 _____	62	302-71000 _____	74
241-10561 _____	197	243-00893 _____	197	247-91896 _____	200	301-76412 _____	62	302-71100 _____	74
241-10570 _____	197	243-00894 _____	197	247-91988 _____	200	301-76512 _____	62	302-71203 _____	74
241-10571 _____	197	243-00895 _____	197	247-91990 _____	200	301-76520 _____	62	302-71233 _____	74
241-10610 _____	197	243-00896 _____	197	247-99515 _____	201	301-76720 _____	62	302-71331 _____	74
241-10611 _____	197	243-00897 _____	197	247-99517 _____	201	301-76721 _____	62	302-71335 _____	74
241-10620 _____	197	243-00898 _____	197	301-01201 _____	64	301-76820 _____	62	302-71500 _____	74
241-10621 _____	197	246-18880 _____	199	301-01220 _____	64	302-00224 _____	72	302-71550 _____	74
241-10630 _____	197	246-18910 _____	199	301-02200 _____	64	302-00225 _____	73	302-72036 _____	93
241-10631 _____	197	246-35010 _____	198	301-02201 _____	64	302-00252 _____	77	302-72081 _____	71
241-10640 _____	197	246-35011 _____	198	301-05620 _____	67	302-00404 _____	77	302-72091 _____	71
241-10641 _____	197	246-35012 _____	198	301-05621 _____	67	302-00502 _____	77	302-72200 _____	72
241-10650 _____	197	246-35020 _____	198	301-05630 _____	67	302-00503 _____	77	302-72212 _____	74
241-10651 _____	197	246-35021 _____	198	301-10120 _____	63	302-03531 _____	73	302-72218 _____	74
241-10660 _____	197	246-35022 _____	198	301-10125 _____	63	302-04532 _____	78	302-72220 _____	74
241-10661 _____	197	246-35030 _____	198	301-10129 _____	63	302-10802 _____	83	302-72225 _____	74
241-10670 _____	197	246-35031 _____	198	301-10200 _____	63	302-10803 _____	83	302-72230 _____	74
241-10671 _____	197	246-35032 _____	198	301-10205 _____	63	302-14140 _____	79	302-81004 _____	85
241-10710 _____	197	246-35040 _____	198	301-10208 _____	63	302-14360 _____	86	302-81006 _____	85
241-10711 _____	197	246-35041 _____	198	301-10209 _____	63	302-14400 _____	86	302-81012 _____	85
241-10720 _____	197	246-35042 _____	198	301-10300 _____	63	302-14405 _____	86	302-81022 _____	82
241-10721 _____	197	246-35060 _____	198	301-10381 _____	68	302-14470 _____	71	302-81033 _____	82
241-10730 _____	197	246-35061 _____	198	301-10382 _____	68	302-19150 _____	70	302-81034 _____	82

NUMERIC INDEX (CONT.)

302-81035 _____ 82	308-93737 _____ 91	312-14923 _____ 252	319-00787 _____ 219	335-05286 _____ 226
302-81122 _____ 82	309-00925 _____ 103	312-15224 _____ 252	319-02011 _____ 219	341-00114 _____ 202
302-81205 _____ 85	309-12121 _____ 69	312-25224 _____ 252	319-19800 _____ 204	341-00119 _____ 202
302-81208 _____ 85	309-14462 _____ 69	312-39001 _____ 252	319-20311 _____ 219	341-01352 _____ 202
302-81209 _____ 85	309-14463 _____ 69	314-07180 _____ 227	319-99601 _____ 220	351-00909 _____ 224
302-81210 _____ 85	309-14464 _____ 69	314-09852 _____ 227	319-99602 _____ 220	351-00919 _____ 224
302-81225 _____ 83, 85	309-14465 _____ 69	316-00012 _____ 19	319-99611 _____ 220	351-01326 _____ 223
302-82205 _____ 85	309-14466 _____ 69	316-00058 _____ 19	319-99643 _____ 220	351-03110 _____ 225
302-82208 _____ 85	309-14468 _____ 69	316-00078 _____ 19	319-99644 _____ 220	351-03418 _____ 225
302-82209 _____ 85	309-14469 _____ 69	316-00102 _____ 19	319-99650 _____ 220	356-00100 _____ 223
302-82210 _____ 85	309-14472 _____ 69	316-00507 _____ 19	319-99660 _____ 219	356-09008 _____ 227
302-82225 _____ 83, 85	309-14473 _____ 69	316-00709 _____ 19	319-99675 _____ 219	361-02280 _____ 228
302-91000 _____ 80	309-14500 _____ 69	316-00716 _____ 19	322-00015 _____ 215	361-03030 _____ 228
302-91001 _____ 80	309-14501 _____ 69	316-00911 _____ 19	322-17432 _____ 214	361-09010 _____ 230
302-91003 _____ 80	309-14503 _____ 69	316-00916 _____ 19	322-17892 _____ 214	361-34788 _____ 228
302-91004 _____ 80	309-18181 _____ 69	316-01098 _____ 19	322-19202 _____ 213	361-34789 _____ 228
302-91005 _____ 80	309-24468 _____ 69	316-01113 _____ 19	322-24034 _____ 214	366-05039 _____ 230
302-92000 _____ 76	309-40080 _____ 90	316-01315 _____ 19	322-24037 _____ 214	366-45111 _____ 230
302-92003 _____ 75	309-72501 _____ 88	316-01517 _____ 19	322-41122 _____ 211	368-00201 _____ 229
302-92004 _____ 76	309-72502 _____ 88	316-01518 _____ 19	322-41123 _____ 211	368-00202 _____ 229
302-92006 _____ 75	309-72504 _____ 88	316-01720 _____ 19	322-41124 _____ 211	369-07610 _____ 230
302-92007 _____ 75	309-72505 _____ 88	316-01922 _____ 19	322-41125 _____ 211	371-41000 _____ 89
302-92010 _____ 76	309-72506 _____ 88	316-02023 _____ 19	322-41126 _____ 211	371-41001 _____ 89
302-93200 _____ 90	309-72507 _____ 88	316-02225 _____ 19	322-41127 _____ 211	371-42000 _____ 89
302-93503 _____ 84	309-72508 _____ 88	316-02327 _____ 19	322-41203 _____ 213	371-42003 _____ 89
302-93506 _____ 84	309-72517 _____ 88	316-02332 _____ 19	322-41206 _____ 213	371-43000 _____ 89
302-93511 _____ 84	309-72525 _____ 88	316-03740 _____ 19	322-41461 _____ 213	371-72000 _____ 87
302-93512 _____ 84	309-72533 _____ 88	316-91098 _____ 19	322-41467 _____ 213	371-72001 _____ 87
302-93524 _____ 84	309-93248 _____ 90	317-78000 _____ 100	323-13001 _____ 213	371-72701 _____ 87
302-93526 _____ 86	309-93291 _____ 103	317-78021 _____ 100	323-13019 _____ 213	371-93718 _____ 88
302-93657 _____ 79	309-93294 _____ 103	317-78055 _____ 100	323-13022 _____ 213	371-93720 _____ 89
302-93659 _____ 94	309-93721 _____ 90	317-78056 _____ 100	323-13133 _____ 213	372-00103 _____ 229
302-93660 _____ 79	311-21500 _____ 203	317-78057 _____ 100	324-41456 _____ 211	372-07028 _____ 103
302-93662 _____ 79	311-28805 _____ 203	317-78058 _____ 100	324-41457 _____ 211	392-00805 _____ 217
302-93667 _____ 79	311-28806 _____ 203	317-78077 _____ 100	328-00016 _____ 32	392-00838 _____ 217
302-93731 _____ 79	311-28807 _____ 203	317-78078 _____ 100	328-10001 _____ 32	392-00839 _____ 217
302-93733 _____ 71	311-28808 _____ 203	317-78110 _____ 100	329-00505 _____ 215	395-00101 _____ 206
302-93735 _____ 78	311-28810 _____ 203	317-78111 _____ 100	329-08874 _____ 212	395-00102 _____ 206
308-00140 _____ 179	311-28811 _____ 203	317-93300 _____ 101	329-08878 _____ 212	395-00103 _____ 206
308-00190 _____ 179	311-28812 _____ 203	317-93400 _____ 101	329-08890 _____ 212	395-00104 _____ 206
308-10320 _____ 80	311-28813 _____ 203	317-93610 _____ 101	329-08895 _____ 212	395-00125 _____ 206
308-10321 _____ 80	311-28814 _____ 203	318-10518 _____ 119	329-18685 _____ 215	395-00126 _____ 206
308-10322 _____ 80	311-64055 _____ 203	318-11090 _____ 118	329-19702 _____ 215	395-00300 _____ 206
308-10323 _____ 80	311-64065 _____ 203	319-00357 _____ 204	329-19732 _____ 215	395-00400 _____ 206
308-10324 _____ 80	311-64650 _____ 203	319-00358 _____ 204, 250	329-19852 _____ 214	395-06400 _____ 206
308-34100 _____ 92	311-64800 _____ 203	319-00435 _____ 204	329-21250 _____ 230	395-06401 _____ 206
308-82990 _____ 92	312-03007 _____ 251	319-00436 _____ 204	329-21251 _____ 230	395-09552 _____ 206
308-82992 _____ 92	312-03120 _____ 251	319-00437 _____ 250	329-24068 _____ 214	395-13124 _____ 205
308-82999 _____ 93	312-04146 _____ 251	319-00447 _____ 250	331-01750 _____ 103	395-40000 _____ 206
308-83999 _____ 93	312-04147 _____ 251	319-00526 _____ 204	331-05015 _____ 103	395-42023 _____ 205
308-93690 _____ 91	312-05224 _____ 252	319-00555 _____ 219	335-05025 _____ 225	395-44020 _____ 205
308-93693 _____ 91	312-08473 _____ 252	319-00777 _____ 219	335-05280 _____ 226	395-45507 _____ 205

NUMERIC INDEX (CONT.)

395-72552 ____ 206	396-49101 ____ 222	402-00100 ____ 131	402-20416 ____ 131	402-33024 ____ 133
395-72554 ____ 206	396-49102 ____ 222	402-00101 ____ 131	402-20418 ____ 119	402-33052 ____ 133
395-72722 ____ 206	396-49103 ____ 222	402-00112 ____ 58	402-20430 ____ 131	402-33062 ____ 133
395-72724 ____ 206	396-49104 ____ 222	402-00113 ____ 58	402-21019 ____ 44	402-33195 ____ 132
395-83039 ____ 205	396-55220 ____ 222	402-00118 ____ 58	402-21021 ____ 44	402-33196 ____ 132
396-00102 ____ 218	396-55221 ____ 222	402-00120 ____ 58	402-21022 ____ 44	402-33199 ____ 132
396-00301 ____ 221	396-55222 ____ 222	402-00122 ____ 58	402-21030 ____ 44	402-33219 ____ 133
396-00302 ____ 221	396-55223 ____ 222	402-00128 ____ 58	402-21031 ____ 44	402-33220 ____ 133
396-00303 ____ 221	396-62150 ____ 217	402-00200 ____ 131	402-21032 ____ 44	402-33223 ____ 135
396-00304 ____ 221	396-72150 ____ 217	402-00201 ____ 131	402-21033 ____ 44	402-33238 ____ 133
396-00305 ____ 221	396-72182 ____ 217	402-01322 ____ 59	402-21036 ____ 44	402-33239 ____ 133
396-00401 ____ 221	396-73601 ____ 216	402-02001 ____ 133	402-21038 ____ 44	402-34402 ____ 140
396-00402 ____ 221	396-73611 ____ 216	402-02002 ____ 133	402-21040 ____ 44	402-34645 ____ 135
396-00403 ____ 221	396-73621 ____ 216	402-02005 ____ 133	402-21041 ____ 44	402-34649 ____ 135
396-00404 ____ 221	396-82150 ____ 217	402-02006 ____ 133	402-21044 ____ 44	402-34950 ____ 132
396-00405 ____ 221	396-90306 ____ 217	402-02100 ____ 133	402-21046 ____ 44	402-35440 ____ 133
396-00802 ____ 221	396-90333 ____ 217	402-02101 ____ 133	402-23133 ____ 44	402-37330 ____ 59
396-00803 ____ 221	396-92150 ____ 217	402-02102 ____ 133	402-24027 ____ 44	402-37335 ____ 59
396-00804 ____ 221	396-93150 ____ 217	402-03016 ____ 49	402-24028 ____ 44	402-37340 ____ 59
396-00805 ____ 221	396-96110 ____ 217	402-03116 ____ 49	402-24030 ____ 44	402-37350 ____ 58
396-00901 ____ 216	399-00005 ____ 209	402-11000 ____ 52	402-24032 ____ 44	402-37351 ____ 58
396-00902 ____ 216	399-00011 ____ 209	402-17000 ____ 52	402-24033 ____ 44	402-37355 ____ 58
396-06780 ____ 222	399-00101 ____ 207	402-18000 ____ 52	402-24038 ____ 44	402-43351 ____ 58
396-10011 ____ 221	399-00102 ____ 207	402-20001 ____ 43	402-24133 ____ 44	402-43352 ____ 58
396-12590 ____ 218	399-00103 ____ 207	402-20015 ____ 43	402-25021 ____ 44	402-43357 ____ 58
396-12593 ____ 218	399-11111 ____ 207	402-20017 ____ 43	402-25022 ____ 44	402-43358 ____ 58
396-12594 ____ 218	399-60000 ____ 210	402-20018 ____ 43	402-25032 ____ 44	402-45003 ____ 130
396-12596 ____ 218	399-60098 ____ 208	402-20019 ____ 43	402-25033 ____ 44	402-45004 ____ 130
396-14200 ____ 216	399-74980 ____ 209	402-20020 ____ 43	402-25133 ____ 44	402-45005 ____ 130
396-14201 ____ 221	399-98313 ____ 208	402-20021 ____ 43	402-30601 ____ 45	402-46000 ____ 135
396-14202 ____ 221	399-98893 ____ 210	402-20023 ____ 43	402-30602 ____ 45	402-46001 ____ 135
396-14955 ____ 216	399-99302 ____ 208	402-20024 ____ 43	402-30603 ____ 45	402-46002 ____ 135
396-15300 ____ 218	399-99323 ____ 208	402-20026 ____ 43	402-30604 ____ 45	402-46003 ____ 135
396-15336 ____ 218	399-99432 ____ 208	402-20027 ____ 43	402-30606 ____ 49	402-47000 ____ 135
396-15337 ____ 218	399-99433 ____ 209	402-20028 ____ 43	402-30607 ____ 45	402-47001 ____ 130
396-15338 ____ 218	399-99479 ____ 208	402-20029 ____ 43	402-30608 ____ 45	402-47001 ____ 135
396-15339 ____ 218	401-00700 ____ 57	402-20030 ____ 43	402-30609 ____ 45	402-47002 ____ 135
396-15342 ____ 218	401-10160 ____ 55	402-20032 ____ 43	402-31820 ____ 133	402-47003 ____ 135
396-15353 ____ 218	401-10170 ____ 55	402-20033 ____ 43	402-32101 ____ 133	402-50301 ____ 52
396-20773 ____ 216	401-10220 ____ 55	402-20034 ____ 43	402-32102 ____ 133	402-62000 ____ 45
396-21000 ____ 216	401-10221 ____ 55	402-20035 ____ 43	402-32119 ____ 133	402-62500 ____ 45
396-23412 ____ 216	401-10280 ____ 55	402-20036 ____ 43	402-32120 ____ 133	402-62600 ____ 45
396-23421 ____ 216	401-10290 ____ 55	402-20040 ____ 43	402-32123 ____ 135	403-35595 ____ 139
396-23430 ____ 216	401-10430 ____ 55	402-20041 ____ 43	402-32420 ____ 133	403-35636 ____ 139
396-30551 ____ 217	401-10431 ____ 55	402-20044 ____ 43	402-32610 ____ 59	403-35695 ____ 139
396-30552 ____ 217	401-10810 ____ 55	402-20046 ____ 43	402-32611 ____ 59	403-35696 ____ 139
396-30553 ____ 217	401-69260 ____ 57	402-20078 ____ 43	402-32613 ____ 59	403-35697 ____ 139
396-30554 ____ 217	401-69290 ____ 57	402-20114 ____ 43	402-32614 ____ 59	403-35795 ____ 139
396-30561 ____ 217	402-00013 ____ 58	402-20133 ____ 44	402-32615 ____ 59	404-34543 ____ 140
396-30562 ____ 217	402-00014 ____ 58	402-20333 ____ 43	402-32616 ____ 59	404-34545 ____ 140
396-30563 ____ 217	402-00016 ____ 58	402-20396 ____ 131	402-33020 ____ 133	404-34547 ____ 140
396-30564 ____ 217	402-00022 ____ 58	402-20397 ____ 131	402-33021 ____ 133	404-67300 ____ 48
396-40317 ____ 222	402-00028 ____ 58	402-20406 ____ 131	402-33022 ____ 133	405-32501 ____ 140

NUMERIC INDEX (CONT.)

405-32502 _____ 140	417-12613 _____ 146	422-71650 _____ 141	432-02146 _____ 106	437-00002_ 104, 107
405-32503 _____ 140	417-12614 _____ 146	422-71655 _____ 141	432-02167 _____ 106	437-00003_ 104, 107
405-32504 _____ 140	417-12615 _____ 146	422-94549 _____ 141	432-12012 _____ 108	437-13014 _____ 104
405-32505 _____ 140	417-12616 _____ 146	423-00101 _____ 115	432-12014 _____ 108	437-40006 _____ 104
405-32506 _____ 140	417-12617 _____ 146	424-35327 _____ 137	432-12178 _____ 108	443-00409 _____ 177
405-32508 _____ 140	417-12618 _____ 146	424-35329 _____ 137	432-12180 _____ 108	443-01504 _____ 177
405-32509 _____ 140	417-12619 _____ 146	424-35427 _____ 137	432-12183 _____ 108	443-01804 _____ 176
405-32551 _____ 140	417-12704 _____ 146	424-35429 _____ 137	432-12214 _____ 108	443-03504 _____ 176
405-32552 _____ 140	417-13003 _____ 145	425-35105 _____ 136	432-12278 _____ 108	443-03514 _____ 176
405-32553 _____ 140	417-13004 _____ 145	425-35321 _____ 136	432-12280 _____ 108	443-04002 _____ 177
405-32556 _____ 140	417-13005 _____ 145	425-35323 _____ 136	432-12282 _____ 108	443-90201 _____ 178
405-32557 _____ 140	417-13006 _____ 145	425-35325 _____ 136	432-12490 _____ 107	446-00027 _____ 175
405-34401 _____ 140	417-13007 _____ 145	425-35421 _____ 136	432-12492 _____ 107	446-00056 _____ 175
406-30609 _____ 138	417-16210 _____ 145	425-35423 _____ 136	432-57270 _____ 105	448-00001 _____ 126
406-30610 _____ 138	417-16211 _____ 145	425-35425 _____ 136	432-57304 _____ 105	448-00010 _____ 130
406-30612 _____ 138	417-39120 _____ 145	426-10062 _____ 136	432-57305 _____ 105	448-00100 _____ 130
406-30618 _____ 138	417-39121 _____ 145	426-10064 _____ 136	432-57355 _____ 105	448-00101 _____ 130
406-30619 _____ 138	417-39122 _____ 145	426-10066 _____ 136	433-01950 _____ 107	448-00200 _____ 130
406-30620 _____ 138	417-39202 _____ 146	426-27804 _____ 136	433-01957 _____ 107	448-00201 _____ 130
406-60300 _____ 138	417-39203 _____ 146	426-28045 _____ 136	433-01958 _____ 107	448-00202 _____ 130
406-60301 _____ 138	421-00098 _____ 118	426-29045 _____ 136	433-02020 _____ 107	448-00301 _____ 130
406-60302 _____ 138	421-00100 _____ 118	426-30025 _____ 136	433-02022 _____ 107	448-00400 _____ 131
406-60303 _____ 138	421-12904 _____ 126	426-35110 _____ 137	433-02023 _____ 107	448-01100 _____ 130
406-60908 _____ 138	422-10100 _____ 117	426-35411 _____ 137	433-02053 _____ 108	448-01101 _____ 73
407-00350 _____ 102	422-10101 _____ 115	426-35417 _____ 137	433-02054 _____ 108	448-01102 _____ 73
407-02000 _____ 96	422-10103 _____ 117	427-12026 _____ 119	433-02055 _____ 108	448-01103 _____ 73
407-03000 _____ 96	422-10200 _____ 115	427-35924 _____ 119	433-25430 _____ 109	448-12100 _____ 131
407-10400 _____ 96	422-10201 _____ 115	427-35926 _____ 119	433-25431 _____ 109	448-12320 _____ 130
407-11100 _____ 96	422-10202 _____ 115	427-45926 _____ 119	433-81505 _____ 108	448-12880 _____ 126
407-11200 _____ 96	422-10316 _____ 119	429-35111 _____ 137	433-81511 _____ 108	448-12894 _____ 127
407-11600 _____ 96	422-10825 _____ 115	429-35113 _____ 137	433-81515 _____ 108	448-22320 _____ 130
407-11900 _____ 96	422-10839 _____ 115	429-35119 _____ 137	433-81555 _____ 108	448-22894 _____ 127
407-12000 _____ 96	422-11000 _____ 116	429-35127 _____ 137	434-02110 _____ 106	448-32320 _____ 130
407-46000 _____ 102	422-11005 _____ 116	429-35129 _____ 137	434-02120 _____ 106	448-32894 _____ 127
407-47050 _____ 98	422-11010 _____ 115	429-35206 _____ 137	435-00015 _____ 106	448-42894 _____ 127
407-47053 _____ 99	422-11015 _____ 117	429-35211 _____ 137	435-00125 _____ 106	448-71000 _____ 130
407-47105 _____ 97	422-11020 _____ 115	429-35218 _____ 137	435-01120 _____ 106	451-00006 _____ 111
407-47110 _____ 96	422-11025 _____ 118	429-35219 _____ 137	435-02085 _____ 106	451-00013 _____ 192
407-70130 _____ 97	422-11040 _____ 116	429-35832 _____ 137	435-02086 _____ 106	451-00026 _____ 111
407-70132 _____ 97	422-11044 _____ 117	429-36455 _____ 141	435-02480 _____ 108	451-00036 _____ 111
407-72040 _____ 102	422-11050 _____ 116	432-00730 _____ 107	435-02785 _____ 105	451-00055 _____ 111
407-82302 _____ 95	422-11060 _____ 117	432-00731 _____ 107	435-02786 _____ 105	451-00101 _____ 111
407-82304 _____ 95	422-11065 _____ 117	432-00740 _____ 107	435-06001 _____ 105	451-00150 _____ 193
407-82306 _____ 98	422-11076 _____ 118	432-00750 _____ 107	435-06002 _____ 105	451-00200 _____ 193
407-82310 _____ 97	422-12000 _____ 115	432-00751 _____ 107	435-06003 _____ 105	451-00203 _____ 192
407-82312 _____ 97	422-12020 _____ 115	432-01750 _____ 107	435-06004 _____ 105	451-00204 _____ 192
407-82320 _____ 99	422-12070 _____ 116	432-02000 _____ 106	435-06008 _____ 105	451-00205 _____ 192
407-90538 _____ 99	422-12090 _____ 116	432-02005 _____ 106	435-07001 _____ 105	451-00206 _____ 192
407-93766 _____ 98	422-12110 _____ 117	432-02008 _____ 106	435-07002 _____ 105	451-00208 _____ 192
408-00016 _____ 110	422-16200 _____ 115	432-02014 _____ 106	435-08001 _____ 105	451-00210 _____ 192
411-65201 _____ 163	422-34549 _____ 141	432-02028 _____ 105	435-08002 _____ 105	451-00212 _____ 192
411-97840 _____ 163	422-40801 _____ 118	432-02029 _____ 105	435-08003 _____ 105	451-00214 _____ 192
417-12612 _____ 145	422-47180 _____ 119	432-02035 _____ 105	437-00001_ 104, 107	451-00216 _____ 192

NUMERIC INDEX (CONT.)

451-00250 _____	193	452-00105 _____	114	452-00420 _____	114	452-02109 _____	114	462-01147 _____	153
451-00255 _____	111	452-00106 _____	114	452-00421 _____	114	454-00190 _____	163	462-01224 _____	153
451-00275 _____	111	452-00107 _____	114	452-00422 _____	114	454-00209 _____	164	462-01416 _____	154
451-00300 _____	193	452-00108 _____	114	452-00423 _____	114	454-00599 _____	163	462-01575 _____	154
451-00400 _____	193	452-00109 _____	114	452-00424 _____	114	454-00712 _____	163	462-01600 _____	154
451-00440 _____	111	452-00112 _____	114	452-00425 _____	114	454-01410 _____	170	462-02416 _____	153
451-00500 _____	193	452-00114 _____	114	452-00426 _____	114	454-01420 _____	163	462-03416 _____	154
451-00551 _____	111	452-00201 _____	114	452-00501 _____	114	454-01599 _____	163	462-04100 _____	152
451-00640 _____	110, 111	452-00202 _____	114	452-00502 _____	114	454-05127 _____	163	462-05010 _____	153
451-00707 _____	111	452-00203 _____	114	452-00503 _____	114	454-05131 _____	170	462-06008 _____	153
451-01203 _____	192	452-00204 _____	114	452-00504 _____	114	454-05300 _____	170	462-06027 _____	152
451-01204 _____	192	452-00205 _____	114	452-00505 _____	114	455-00003 _____	113	462-07025 _____	152
451-01206 _____	192	452-00206 _____	114	452-00506 _____	114	455-00129 _____	113	462-08027 _____	152
451-01208 _____	192	452-00207 _____	114	452-00507 _____	114	455-00401 _____	113	462-09027 _____	152
451-01210 _____	192	452-00208 _____	114	452-00508 _____	114	455-00402 _____	113	462-11527 _____	152
451-01212 _____	192	452-00209 _____	114	452-00509 _____	114	455-00403 _____	113	462-16008 _____	153
451-01214 _____	192	452-00210 _____	114	452-00510 _____	114	455-00404 _____	113	463-00500 _____	152
451-01216 _____	192	452-00211 _____	114	452-00511 _____	114	455-00405 _____	113	463-00501 _____	152
451-01640 _____	111	452-00212 _____	114	452-00512 _____	114	455-00406 _____	113	463-00509 _____	152
451-02416 _____	111	452-00213 _____	114	452-00513 _____	114	455-00444 _____	113	463-00510 _____	152
451-02640 _____	111	452-00214 _____	114	452-00514 _____	114	455-04444 _____	113	463-00511 _____	152
451-04128 _____	111	452-00215 _____	114	452-00515 _____	114	455-12500 _____	113	463-00542 _____	152
451-05510 _____	111	452-00216 _____	114	452-00516 _____	114	455-15017 _____	113	463-00543 _____	152
451-06000 _____	193	452-00217 _____	114	452-00517 _____	114	455-15019 _____	113	463-00544 _____	152
451-07000 _____	193	452-00218 _____	114	452-00518 _____	114	456-00405 _____	179	463-00545 _____	152
451-10003 _____	193	452-00219 _____	114	452-00519 _____	114	459-54220 _____	112	463-00546 _____	152
451-14128 _____	111	452-00220 _____	114	452-00520 _____	114	459-54222 _____	112	463-00552 _____	152
451-15405 _____	193	452-00221 _____	114	452-00521 _____	114	459-61126 _____	112	463-00553 _____	152
451-20516 _____	110	452-00222 _____	114	452-00522 _____	114	459-61127 _____	112	463-00570 _____	152
451-20605 _____	193	452-00223 _____	114	452-00523 _____	114	459-61128 _____	112	463-00571 _____	152
451-24128 _____	111	452-00224 _____	114	452-00524 _____	114	459-61129 _____	112	463-00572 _____	152
451-25805 _____	193	452-00225 _____	114	452-00525 _____	114	459-80220 _____	112	463-00573 _____	152
451-31005 _____	193	452-00226 _____	114	452-00526 _____	114	459-80221 _____	112	463-00574 _____	152
451-32016 _____	194	452-00401 _____	114	452-01100 _____	114	459-80222 _____	112	463-00575 _____	152
451-40004 _____	194	452-00402 _____	114	452-01101 _____	114	459-80223 _____	112	463-01078 _____	153
451-40006 _____	194	452-00403 _____	114	452-01102 _____	114	459-80225 _____	112	463-01175 _____	153
451-40008 _____	194	452-00404 _____	114	452-01103 _____	114	459-80226 _____	112	463-01177 _____	153
451-40010 _____	194	452-00405 _____	114	452-01104 _____	114	459-80227 _____	112	463-01544 _____	152
451-40012 _____	194	452-00406 _____	114	452-01105 _____	114	459-80228 _____	112	463-01553 _____	152
451-40013 _____	193	452-00407 _____	114	452-01106 _____	114	459-80229 _____	112	463-01555 _____	152
451-40016 _____	194	452-00408 _____	114	452-01107 _____	114	459-80230 _____	112	463-01571 _____	154
451-60021 _____	193	452-00409 _____	114	452-01108 _____	114	459-80231 _____	112	463-01572 _____	154
451-72305 _____	193	452-00410 _____	114	452-01109 _____	114	459-80232 _____	112	463-01573 _____	154
452-00001 _____	114	452-00411 _____	114	452-02100 _____	114	459-80250 _____	112	463-02553 _____	152
452-00011 _____	114	452-00412 _____	114	452-02101 _____	114	459-80257 _____	112	463-02554 _____	152
452-00012 _____	114	452-00413 _____	114	452-02102 _____	114	459-80258 _____	112	463-02555 _____	152
452-00014 _____	114	452-00414 _____	114	452-02103 _____	114	459-80271 _____	112	463-03553 _____	152
452-00100 _____	114	452-00415 _____	114	452-02104 _____	114	459-85100 _____	112	463-03554 _____	152
452-00101 _____	114	452-00416 _____	114	452-02105 _____	114	462-00417 _____	153	463-05433 _____	152
452-00102 _____	114	452-00417 _____	114	452-02106 _____	114	462-00430 _____	153	463-05434 _____	152
452-00103 _____	114	452-00418 _____	114	452-02107 _____	114	462-00523 _____	153	463-05435 _____	152
452-00104 _____	114	452-00419 _____	114	452-02108 _____	114	462-00962 _____	153	463-05444 _____	152

NUMERIC INDEX (CONT.)

463-05454 _____ 152	468-00765 _____ 152	468-40007 _____ 159	469-06572 _____ 151	473-01505 _____ 120
463-05464 _____ 152	468-00765 _____ 158	468-40010 _____ 159	469-08453 _____ 151	473-01506 _____ 120
463-05465 _____ 152	468-00808 _____ 159	468-90597 _____ 159	469-08572 _____ 151	473-01507 _____ 120
463-05474 _____ 152	468-01032 _____ 159	468-90599 _____ 159	469-10453 _____ 151	473-01508 _____ 120
463-15454 _____ 152	468-01033 _____ 159	468-95911 _____ 159	469-10572 _____ 151	473-01509 _____ 120
463-54636 _____ 152	468-01034 _____ 159	469-00001 _____ 161	469-11115 _____ 162	473-01510 _____ 120
464-00134 _____ 128	468-01035 _____ 159	469-00002 _____ 162	469-15407 _____ 161	473-01511 _____ 120
464-00135 _____ 128	468-01037 _____ 159	469-00003 _____ 161	469-15720 _____ 157	473-01512 _____ 120
464-00136 _____ 128	468-01038 _____ 159	469-00004 _____ 162	469-22011 _____ 155	473-01513 _____ 120
464-00137 _____ 128	468-01039 _____ 159	469-00005 _____ 161	469-22012 _____ 155	473-01514 _____ 120
464-00138 _____ 128	468-01120 _____ 234	469-00006 _____ 161	469-23430 _____ 162	473-01515 _____ 120
464-00139 _____ 128	468-01390 _____ 159	469-00011 _____ 162	469-32011 _____ 155	473-02102 _____ 123
464-00140 _____ 128	468-01391 _____ 159	469-00014 _____ 161	469-32012 _____ 155	473-02103 _____ 123
464-00141 _____ 128	468-01392 _____ 159	469-00018 _____ 155	469-32850 _____ 162	473-02106 _____ 123
464-00142 _____ 128	468-01393 _____ 159	469-00018 _____ 162	469-32851 _____ 162	473-02107 _____ 123
464-00143 _____ 128	468-01462 _____ 152	469-00020 _____ 155, 162	469-35934 _____ 155	473-02501 _____ 120
464-00144 _____ 128	468-02222 _____ 158	469-00021 _____ 162	469-52000 _____ 162	473-02505 _____ 120
464-00145 _____ 128	468-02462 _____ 152	469-00040 _____ 161	471-31432 _____ 126	473-02510 _____ 120
464-00146 _____ 128	468-04191 _____ 158	469-00081 _____ 162	471-31433 _____ 126	473-02511 _____ 120
464-00310 _____ 128	468-05093 _____ 152	469-00131 _____ 161	471-80007 _____ 154	473-02513 _____ 120
468-00102 _____ 158	468-05952 _____ 152	469-00132 _____ 161	471-80008 _____ 154	473-03102 _____ 123
468-00103 _____ 152	468-05953 _____ 152	469-00133 _____ 161	471-80010 _____ 154	473-03103 _____ 123
468-00307 _____ 152	468-05954 _____ 152	469-00134 _____ 161	471-80012 _____ 154	473-03104 _____ 123
468-00330 _____ 159	468-06541 _____ 158	469-00567 _____ 162	472-31710 _____ 132	473-03106 _____ 123
468-00331 _____ 159	468-08028 _____ 159	469-00580 _____ 155	472-31713 _____ 132	473-04103 _____ 123
468-00341 _____ 159	468-10004 _____ 159	469-00590 _____ 155	472-31810 _____ 132	473-05102 _____ 123
468-00346 _____ 159	468-10011 _____ 158	469-00607 _____ 161	472-31810 _____ 132	473-06813 _____ 123
468-00347 _____ 159	468-10012 _____ 158	469-00609 _____ 162	473-00005 _____ 127	473-12913 _____ 124
468-00348 _____ 159	468-10013 _____ 159	469-00612 _____ 161	473-00010 _____ 122	473-12914 _____ 124
468-00349 _____ 159	468-10015 _____ 159	469-00625 _____ 161	473-00011 _____ 122	473-12915 _____ 124
468-00350 _____ 159	468-10017 _____ 158	469-00630 _____ 161	473-00013 _____ 122	473-12916 _____ 124
468-00356 _____ 159	468-10019 _____ 158	469-00632 _____ 161	473-00015 _____ 125	473-12917 _____ 124
468-00370 _____ 160	468-10039 _____ 159	469-00633 _____ 161	473-00020 _____ 125	473-12919 _____ 124
468-00371 _____ 160	468-10046 _____ 159	469-00673 _____ 162	473-00038 _____ 121	473-12920 _____ 124
468-00372 _____ 160	468-10054 _____ 159	469-00992 _____ 161	473-00100 _____ 124	473-12921 _____ 124
468-00373 _____ 160	468-10060 _____ 152, 159	469-01115 _____ 162	473-00103 _____ 124	473-12923 _____ 124
468-00381 _____ 160	468-10070 _____ 152	469-01124 _____ 161	473-00106 _____ 124	473-12930 _____ 124
468-00382 _____ 160	468-10117 _____ 159	469-01638 _____ 161	473-00110 _____ 124	473-12941 _____ 125
468-00383 _____ 160	468-11700 _____ 159	469-01820 _____ 155	473-00207 _____ 122	473-12942 _____ 125
468-00389 _____ 160	468-12222 _____ 158	469-02311 _____ 111	473-00500 _____ 122	473-20387 _____ 123
468-00390 _____ 160	468-13500 _____ 160	469-02312 _____ 111	473-00501 _____ 122	473-20388 _____ 123
468-00391 _____ 160	468-13501 _____ 160	469-02453 _____ 151	473-01104 _____ 123	473-20389 _____ 123
468-00392 _____ 160	468-13510 _____ 160	469-02570 _____ 154	473-01106 _____ 123	473-36016 _____ 125
468-00393 _____ 160	468-13511 _____ 160	469-02572 _____ 154	473-01107 _____ 123	473-36017 _____ 125
468-00394 _____ 160	468-13520 _____ 160	469-02573 _____ 154	473-01109 _____ 123	473-42561 _____ 127
468-00395 _____ 160	468-13521 _____ 160	469-03333 _____ 161	473-01110 _____ 121	475-00891 _____ 144
468-00396 _____ 160	468-13530 _____ 160	469-04416 _____ 151	473-01113 _____ 121	475-00892 _____ 144
468-00397 _____ 160	468-13531 _____ 160	469-04572 _____ 151	473-01118 _____ 121	475-00893 _____ 144
468-00462 _____ 152	468-16541 _____ 158	469-05262 _____ 162	473-01230 _____ 123	475-00894 _____ 144
468-00607 _____ 152	468-26541 _____ 158	469-05700 _____ 157	473-01500 _____ 120	475-00895 _____ 144
468-00632 _____ 158	468-30007 _____ 159	469-05720 _____ 157	473-01502 _____ 120	475-00896 _____ 142
468-00707 _____ 152	468-30010 _____ 159	469-06453 _____ 151	473-01504 _____ 120	475-00896 _____ 144

NUMERIC INDEX (CONT.)

475-01892	142	476-07263	167	477-00577	172	478-03301	168	481-00212	178
475-01893	142	476-07275	165	477-00587	173	478-03330	168	484-00006	183
475-01894	142	476-07278	167	477-01006	174	478-03370	168	484-00012	183
475-01895	142	476-07285	165	477-01009	174	478-04500	168	484-00060	184
475-01896	142	476-08500	166	477-01012	174	478-04501	168	484-00112	183
475-01897	142	476-08501	166	477-01111	174	478-04660	170	484-00300	184
475-01898	142	476-08860	165	477-01112	174	478-05265	168	484-03200	186
475-09062	143	476-08900	166	477-10001	172	478-05451	168	484-07500	186
475-10509	128	476-10135	163	477-10004	172	478-06172	167	484-10101	186
475-11590	128	476-10155	163	477-10312	171	478-06173	167	484-10201	186
475-12532	129	476-10165	163	477-11111	174	478-06174	167	484-10301	186
475-13011	129	476-10185	163	477-11235	171	478-06175	167	484-10720	183
475-13018	129	476-10240	170	477-11237	171	478-06176	167	484-11360	183
475-13019	129	476-10250	170	477-11239	171	478-06190	170	484-13360	183
475-13021	129	476-10255	170	477-11240	171	478-06293	168	484-16001	184
475-13022	129	476-10480	163	477-11612	171	478-06585	168	484-17026	184
475-13026	129	476-11048	163, 165	477-11623	144	478-06999	167	484-17127	184
475-13027	129	476-11135	163	477-11624	144	478-10013	170	484-20576	184
475-13028	129	476-11148	163	477-11625	144	478-16174	167	484-20624	184
475-13029	129	476-11155	163	477-72623	172	478-16999	167	484-21576	186
475-13030	129	476-11185	163	477-72629	172	478-32072	169	484-21624	186
475-13031	129	476-17275	165	477-76023	173	478-62930	167	484-22576	184
475-13032	129	476-17285	165	477-76029	173	478-62931	167	484-22800	181
475-13033	129	476-27275	165	477-76063	173	478-62932	167	484-27026	184
475-13034	129	476-32380	164	477-76069	173	478-62933	167	484-28408	185
475-15090	128	476-35020	166	478-00001	168	478-62934	167	484-28418	185
475-15103	129	476-35021	166	478-00305	168	478-62935	167	484-28428	185
475-18001	129	476-37285	165	478-00315	168	479-02130	148	484-30336	184
475-30280	129	477-00001	174	478-00322	170	479-02220	148	484-30360	183
475-30281	129	477-00002	174	478-00325	168	479-02240	148	484-30836	185
475-82515	129	477-00003	174	478-00326	170	479-02260	148	484-31230	183
475-89001	142	477-00004	174	478-00328	170	479-36001	149	484-31231	183
475-89003	142	477-00005	174	478-00335	168	479-36002	149	484-31233	183
475-89004	142	477-00008	174	478-00340	168	479-36003	147	484-31234	185
475-89103	143	477-00009	174	478-00345	169	479-36004	147	484-31252	183
476-00001	167	477-00010	174	478-00346	169	479-36005	149	484-31360	184
476-00002	167	477-00011	174	478-00360	144	479-36006	149	484-31430	183
476-00003	167	477-00012	174	478-00377	170	479-36011	149	484-31432	183
476-00135	165	477-00014	174	478-00707	168	479-36013	149	484-31500	185
476-00165	165	477-00015	174	478-00820	142	479-36014	150	484-31501	185
476-00185	165	477-00020	174	478-01330	168	479-36015	149	484-32230	185
476-00250	165	477-00033	174	478-01335	168	479-36111	150	484-32252	185
476-00255	165	477-00066	174	478-01340	168	479-36115	150	484-32360	186
476-00274	164	477-00099	174	478-01345	169	479-36201	149	484-33252	183
476-01046	165	477-00111	174	478-01346	169	479-36211	149	484-35320	185, 187
476-02555	170	477-00112	174	478-01350	168	479-46001	147	484-37026	184
476-03238	164	477-00113	174	478-01351	168	479-46002	147	484-40848	185
476-03502	166	477-00115	174	478-02975	169	479-46005	147	484-41215	183
476-07125	165	477-00118	174	478-02985	168	479-46006	147	484-41226	185
476-07233	165, 170	477-00144	174	478-02995	168	479-46010	147	484-41230	183
476-07248	167	477-00404	173	478-03238	168	479-46011	147	484-41232	183
476-07262	165	477-00409	174	478-03300	144, 168	481-00206	178	484-41500	185

NUMERIC INDEX (CONT.)

484-41501 _____ 185	489-02100 _____ 180	489-21300 _____ 182	491-00065 _____ 51	491-02919 _____ 53
484-42010 _____ 185, 187	489-02120 _____ 180	489-21350 _____ 182	491-00066 _____ 51	491-02928 _____ 53
484-47026 _____ 187	489-02140 _____ 180	489-21400 _____ 182	491-00101 _____ 47	491-02939 _____ 53
484-48312 _____ 185	489-02160 _____ 180	489-21450 _____ 182	491-00123 _____ 52	491-03083 _____ 52
484-48322 _____ 185	489-05005 _____ 180	489-21500 _____ 182	491-00133 _____ 54	491-03087 _____ 52
484-50615 _____ 185	489-05010 _____ 180	489-22100 _____ 181	491-00149 _____ 51	491-03096 _____ 52
484-51215 _____ 183	489-05015 _____ 180	489-22150 _____ 181	491-00233 _____ 52	491-03097 _____ 52
484-51500 _____ 187	489-05020 _____ 180	489-22200 _____ 181	491-00235 _____ 52	491-03098 _____ 52
484-51501 _____ 187	489-05025 _____ 180	489-22250 _____ 181	491-00238 _____ 52	491-03099 _____ 52
484-51502 _____ 187	489-05030 _____ 180	489-22300 _____ 181	491-00257 _____ 52	491-03101 _____ 52
484-51503 _____ 187	489-05035 _____ 180	489-22350 _____ 181	491-00304 _____ 50	491-03103 _____ 52
484-52001 _____ 185, 187	489-05040 _____ 180	489-22400 _____ 181	491-00306 _____ 50	491-03104 _____ 52
484-52312 _____ 185	489-05045 _____ 180	489-22500 _____ 181	491-00399 _____ 52	491-03113 _____ 52
484-53215 _____ 183	489-05050 _____ 180	489-22600 _____ 181	491-00426 _____ 57	491-03271 _____ 52
484-57026 _____ 187	489-05060 _____ 180	489-23100 _____ 182	491-00600 _____ 50	491-03279 _____ 52
484-61215 _____ 183	489-08025 _____ 180	489-23200 _____ 182	491-00654 _____ 51	491-04009 _____ 51
484-61500 _____ 187	489-08050 _____ 180	489-23300 _____ 182	491-00708 _____ 50	491-04012 _____ 51
484-61501 _____ 187	489-08075 _____ 180	489-23400 _____ 182	491-00709 _____ 50	491-04013 _____ 51
484-61502 _____ 187	489-08100 _____ 180	489-23500 _____ 182	491-00716 _____ 51	491-04020 _____ 51
484-61503 _____ 187	489-08125 _____ 180	489-23600 _____ 182	491-00729 _____ 52	491-04021 _____ 51
484-63215 _____ 183	489-08150 _____ 180	489-24200 _____ 181	491-00881 _____ 50	491-06012 _____ 51
484-67026 _____ 186	489-08175 _____ 180	489-24300 _____ 181	491-00888 _____ 50	491-06014 _____ 51
484-77026 _____ 186	489-08200 _____ 180	489-24400 _____ 181	491-00889 _____ 50	491-06020 _____ 51
486-00011 _____ 190	489-08225 _____ 180	489-24500 _____ 181	491-00891 _____ 50	491-06021 _____ 51
486-00044 _____ 189	489-08250 _____ 180	489-24600 _____ 181	491-00892 _____ 50	491-06023 _____ 51
486-00133 _____ 189	489-08275 _____ 180	489-55010 _____ 181	491-00896 _____ 50	491-06024 _____ 51
486-00144 _____ 189	489-08300 _____ 180	489-55020 _____ 181	491-00897 _____ 50	491-06025 _____ 51
486-00222 _____ 190	489-08325 _____ 180	489-55030 _____ 181	491-00978 _____ 50	491-06026 _____ 51
486-00233 _____ 189	489-08350 _____ 180	489-55040 _____ 181	491-00993 _____ 52	491-06115 _____ 52
486-07129 _____ 190	489-08375 _____ 180	489-55050 _____ 181	491-00995 _____ 50	491-09013 _____ 51
486-11000 _____ 189	489-08400 _____ 180	489-55060 _____ 181	491-01133 _____ 54	491-09014 _____ 51
486-11002 _____ 189	489-08425 _____ 180	489-55080 _____ 181	491-01304 _____ 50	491-09015 _____ 51
486-11004 _____ 189	489-08450 _____ 180	489-55100 _____ 181	491-01306 _____ 50	491-32120 _____ 46
486-11005 _____ 189	489-08475 _____ 180	489-55120 _____ 181	491-01339 _____ 47	491-32121 _____ 46
486-11006 _____ 189	489-08500 _____ 180	489-55140 _____ 181	491-01504 _____ 47	491-32124 _____ 46
486-11011 _____ 189	489-09020 _____ 180	489-55160 _____ 181	491-01573 _____ 47	492-00502 _____ 35
486-21638 _____ 205	489-09030 _____ 180	489-64804 _____ 182	491-01594 _____ 47	492-02278 _____ 56
486-31280 _____ 188	489-09040 _____ 180	489-64806 _____ 182	491-01825 _____ 47	492-06247 _____ 48
486-31281 _____ 188	489-09060 _____ 180	489-64808 _____ 182	491-01860 _____ 47	492-06346 _____ 48
486-31282 _____ 188	489-09080 _____ 180	489-64810 _____ 182	491-01896 _____ 50	492-10134 _____ 56
486-33580 _____ 189	489-09100 _____ 180	489-64812 _____ 182	491-01897 _____ 50	492-10150 _____ 56
486-33581 _____ 189	489-09120 _____ 180	491-00014 _____ 51	491-01978 _____ 50	492-10151 _____ 56
486-33584 _____ 189	489-10020 _____ 181	491-00016 _____ 51	491-01995 _____ 50	492-10158 _____ 56
486-51480 _____ 190	489-10030 _____ 181	491-00027 _____ 51	491-02006 _____ 46	492-10159 _____ 56
486-71510 _____ 190	489-10040 _____ 181	491-00033 _____ 50	491-02100 _____ 46	492-10180 _____ 56
486-71511 _____ 190	489-10060 _____ 181	491-00038 _____ 51	491-02101 _____ 46	492-10196 _____ 56
486-75002 _____ 190	489-10080 _____ 181	491-00052 _____ 51	491-02111 _____ 46	492-10340 _____ 56
489-02020 _____ 180	489-21050 _____ 182	491-00053 _____ 52	491-02301 _____ 53	492-10580 _____ 56
489-02030 _____ 180	489-21100 _____ 182	491-00055 _____ 51	491-02431 _____ 51	492-10590 _____ 56
489-02040 _____ 180	489-21150 _____ 182	491-00056 _____ 51	491-02445 _____ 51	492-10780 _____ 56
489-02060 _____ 180	489-21200 _____ 182	491-00062 _____ 51	491-02666 _____ 47	492-14000 _____ 55
489-02080 _____ 180	489-21250 _____ 182	491-00064 _____ 51	491-02906 _____ 53	492-15000 _____ 55

NUMERIC INDEX (CONT.)

492-28950	56	499-10660	56	531-75310	245	535-14182	60	539-06261	246
492-30165	140	499-11171	56	531-75330	245	537-00001	250	539-06310	246
492-30254	49	501-00508	232	531-75370	245	537-00003	243	539-06311	246
492-30649	49	501-00519	232	531-75440	245	537-00004	250	539-06312	246
493-30120	48	501-00532	232	531-95001	113	537-00190	235	539-06313	246
493-30125	48	501-90018	238	531-95002	113	537-00199	235	539-06314	246
493-31210	48	501-90132	238	532-06020	236	537-00353	250	539-06315	246
493-91420	57	502-40541	237	532-06021	236	537-75310	245	539-06316	246
494-01010	110	502-51388	237	533-00003	249	537-90002	244	539-06317	246
494-08907	110	504-00005	111	533-00010	249	537-90003	244	539-06360	246
494-08916	110	504-00055	111	533-00012	249	537-90005	244	539-06361	246
495-16000	38	504-00132	232	533-00045	249	537-90006	244	539-06410	246
495-16001	38	504-00275	111	533-01120	249	537-90009	244	539-06411	246
495-16002	38	504-01132	232	533-01140	249	537-90019	244	539-06412	246
495-16003	38	504-09600	237	533-01141	249	537-90035	244	539-06413	246
495-16004	41	504-09601	237	533-01180	249	537-90045	244	539-06414	246
495-16005	41	504-90005	238	533-01181	249	537-90119	244	539-06415	246
495-16006	41	504-90011	238	533-01182	249	537-90144	239	539-06416	246
495-16007	41	504-90016	238	533-01381	249	537-90150	244	539-06417	246
495-16008	41	505-00071	236	533-01516	249	537-90155	239	539-10001	249
495-16009	41	505-00170	236	533-01716	249	537-90200	244	539-10116	246
495-16014	38	505-00171	236	533-01732	249	537-90201	244	539-10123	246
495-16015	38	505-00176	237	534-80001	249	538-10000	248	539-10136	246
495-16016	38	505-00516	232	534-80005	249	538-10200	248	539-10160	246
495-16017	38	505-00532	232	534-80011	249	538-10700	248	539-10416	246
495-30400	41	505-05320	232	534-80015	249	538-10900	248	539-10423	246
495-30908	41	505-71216	237	534-80024	249	538-11100	248	539-10436	246
495-30909	41	505-90008	238	534-80036	249	538-11200	248	539-10460	246
495-30910	41	505-90032	238	534-80037	249	538-11400	248	539-10916	246
495-30911	41	505-90132	238	534-80115	249	538-11600	248	539-10923	246
495-30913	41	515-00555	24	534-80136	249	538-11800	248	539-10936	246
495-30914	41	517-00039	253	534-80137	249	538-12000	248	539-10960	246
495-30918	41	517-00055	253	534-81115	249	538-12200	248	539-11016	246
495-30919	41	517-00100	253	535-00150	205	538-13000	248	539-11023	246
495-30940	41	517-11033	253	535-14159	104	538-13017	248	539-11036	246
495-97351	39	518-29150	231	535-14164	60	538-13023	248	539-11060	246
495-97352	39	518-90030	239	535-14165	60	538-15000	248	539-15516	247
495-97353	39	531-60070	245	535-14166	104	538-15100	248	539-15536	247
495-97355	39	531-60090	245	535-14168	104	538-15200	248	539-15616	247
495-97361	39	531-60130	245	535-14169	104	538-15400	248	539-15636	247
495-97362	39	531-60150	245	535-14170	60	538-15600	248	539-15816	247
499-10130	56	531-60170	245	535-14171	60	538-60541	239	539-15836	247
499-10150	55	531-60300	245	535-14172	60	539-02203	246	539-16316	247
499-10171	56	531-60310	245	535-14173	60	539-02204	246	539-16336	247
499-10180	56	531-60570	245	535-14174	60	539-02205	246	539-16416	247
499-10200	56	531-70030	245	535-14175	60	539-02206	246	539-16436	247
499-10210	56	531-71050	245	535-14176	60	539-02207	246	539-16516	247
499-10211	56	531-75150	245	535-14177	60	539-02208	246	539-16536	247
499-10340	56	531-75170	245	535-14178	60	539-02209	246	539-18416	247
499-10341	56	531-75190	245	535-14179	60	539-02210	246	539-18436	247
499-10580	56	531-75200	245	535-14180	104	539-02241	246	539-18516	247
499-10581	56	531-75220	245	535-14181	60	539-06260	246	539-18536	247

NUMERIC INDEX (CONT.)

539-18616	247	563-00200	236	577-00146	234	602-60211	254
539-18636	247	563-00210	236	577-00150	234	603-00825	256
539-18716	247	563-00220	236	577-00152	234	603-03000	254
539-18736	247	563-00230	236	577-00155	234	603-82501	256
539-18816	247	563-00240	236	577-00156	234	603-82502	256
539-18836	247	563-00250	236	577-00160	234	603-82503	256
539-28646	248	563-00400	236	577-00162	234	603-82504	256
539-32056	247	563-00410	236	577-00165	234	603-82505	256
539-32058	247	563-00420	236	577-00168	234	603-82506	256
539-32063	247	564-90012	238	577-00175	234	603-82507	256
539-32064	247	564-90013	238	577-00180	234	603-82508	256
539-32065	247	564-90014	238	577-00182	234	603-82509	256
539-33004	247	564-90015	238	577-00184	234	603-82510	256
539-33009	247	564-90016	238	577-00185	234	603-82511	256
539-33010	247	564-90022	238	577-00186	234	604-05045	255
539-33017	247	564-90111	238	577-00188	234	604-05120	255
550-00501	231	571-22926	239	577-00190	234	604-05500	255
550-00502	231	571-91964	239	581-67010	235	605-00101	256
550-00503	231	571-91968	239	581-67045	235	605-14191	256
550-00522	231	575-00110	234	581-67050	235	605-31554	256
550-00533	231	575-00115	234	581-67308	235	632-00005	109
550-00534	231	575-00116	234	581-67340	235	632-00010	109
550-01533	231	575-05109	233	581-68008	235	632-00922	109
550-26707	235	575-05110	233	581-68020	235	632-00923	109
550-26714	235	575-05111	233	581-68406	235	632-01002	109
550-26721	235	575-05112	233	581-68418	235	632-02400	109
550-26738	235	575-05113	233	582-00501	231	632-10001	109
550-26745	235	575-05114	233	582-00502	231	719-00018	240
550-26752	235	575-05115	233	582-00503	231	719-00032	240
562-00501	233	575-05120	233	582-00504	231	719-12001	237, 240
562-00502	233	575-05122	233	582-00522	231	719-12011	237, 240
562-00503	233	575-05124	233	582-00533	231	736-10004	250
562-00504	233	575-05125	233	582-00544	231		
562-00505	233	575-05126	233	582-19311	234		
562-00506	233	575-05135	233	582-19410	234		
562-00507	233	575-05140	233	582-19420	234		
562-00508	233	575-05142	233	582-19430	234		
562-00509	233	575-05144	233	582-19621	234		
562-00511	233	575-15109	233	582-19820	234		
562-26006	236	575-15110	233	585-10071	239		
562-26037	236	575-15112	233	585-30581	239		
562-26044	236	575-15120	233	585-30820	239		
562-26051	236	575-25112	233	587-01150	238		
562-26068	236	576-00120	234	587-01151	238		
562-26075	236	576-00122	234	587-01152	238		
562-26082	236	576-00124	234	587-01303	238		
562-26099	236	576-00125	234	587-01306	238		
562-26109	236	576-00128	234	587-01309	238		
562-26212	236	576-00135	234	587-01406	238		
562-26213	236	576-00140	234	587-01409	238		
562-26314	236	576-00142	234	601-00101	209		
562-26315	236	576-00144	234	602-60210	253		

Ascot Supply Corporation is not responsible for inadvertent typographical errors or omissions. Images included in this publication may appear different to the actual inventoried item.



CHOOSE AME FOR ALL YOUR FLEET TOOL NEEDS



#14460 - 20T A/H
Bottle Jack

**Quality and
Performance without
the Price**



#67510K - Battery
Operated Torque Gun

**Precision Digital
Torque**



#67715 - Break-Away
Style Torque Wrench

**Complete Torque
Solutions**



#71650 - 22.5/24.5 Stuck
Wheel Puller

**Innovative Tools for
Removing Seized
Wheels**





FLEET MAINTENANCE TOOLS



**TC-15
OIL FILTER CRUSHER**
Crushes up to 4 filters at a time in the 9"x16" crush chamber. 38,000 lbs of crushing force. A door safety switch is standard for fleet maintenance facilities where EPA and recycling policies are in effect.

**WS-5
WHEEL WORKSTATION**
Supports the weight of an impact wrench. Moves in all directions and locks into a horizontal plane. Relieves operator fatigue and helps reduce comp claims by preventing back injury.

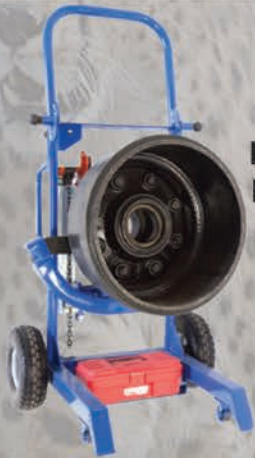

**350B
BACK BUDDY**
Rolls under and bolts onto heavy drum and hub, then roll the assembly out and lay it down for servicing. Re-assembly is quick for perfect hub alignment, eliminating seal damage and costly fixes.

**TW2000
Tweel Handler**
Allows truck mechanics to remove, install, rotate and transport single tire-and-wheel assemblies with ease. Built-in ratcheting jack with 14" of travel.



**405w
PORTA TRUER**
Fast, accurate and dependable. Designed to roll up to any vehicle and true the tire without removing the wheel.

**6346
PakPress**
Stud Remover/ Installer
A must if you're in the Fleet Maintenance industry. Brings the power of a 5-ton shop press right to the truck. A two-hour job is done in twenty minutes.



**FROM THE PEOPLE WHO BROUGHT YOU
THE
CHEETAH BEAD SEATER**



WWW.ASCOTSUPPLY.COM



ASCOT SUPPLY CORPORATION HAS BECOME ONE OF THE LARGEST SUPPLIERS OF BRAND NAME EQUIPMENT, TOOLS, AND SUPPLIES FOR THE TIRE INDUSTRY.

WE ARE HERE TO SERVICE YOUR NEEDS AND SUPPORT YOU EVERY STEP OF THE WAY.