

Model 34800-2K / 34801-2K

Recovery/Recycling/Recharging Unit
for R-12 and R-134a Refrigerants English

Modelo 34800-2K / 34801-2K

Unidad de recuperación/reciclaje/recarga
para refrigerantes R-12 y R-134a Español

Modèle 34800-2K / 34801-2K

Unité de récupération/recyclage/recharge pour les
fluides frigorigènes R-12 et R-134a Français



Refrigerant Recovery,
Recycling and Recharging Station

Series: 34800-2K/34801-2K

Refrigerants: R-12 and R-134a

Voltage—34800-2K: 115V 60 Hz;

34801-2K: 220–240V 50/60 Hz

⚠ WARNINGS ⚠



ALLOW ONLY QUALIFIED PERSONNEL TO OPERATE THE UNIT. Before operating the unit, read and follow the instructions and the warnings in this manual. The operator must be familiar with air conditioning and refrigeration systems, refrigerants, and the dangers of pressurized components. If the operator cannot read English, operating instructions and safety precautions must be read and discussed in the operator's native language.



PRESSURIZED TANK CONTAINS LIQUID REFRIGERANT. Overfilling of the tank may cause violent explosion and possible injury or death. Refer to the instruction manual for tank specifications and ordering information. Do not recover refrigerants into a non-refillable storage container! Federal regulations require refrigerant to be transported only in containers meeting DOT spec. 4BW or DOT spec. 4BA.



ALL HOSES MAY CONTAIN LIQUID REFRIGERANT UNDER PRESSURE. Contact with refrigerant may cause injury. Wear protective equipment, including safety goggles. Disconnect hoses with extreme caution.



HIGH VOLTAGE ELECTRICITY INSIDE PANELS COULD CAUSE ELECTRICAL SHOCK. Disconnect power before servicing unit.



TO REDUCE THE RISK OF FIRE, avoid the use of an extension cord, which may overheat. However, if you must use an extension cord, use a No. 14 AWG minimum, and keep it as short as possible. Do not use this equipment in the vicinity of spilled or open containers of gasoline or other flammable substances.



AVOID BREATHING A/C REFRIGERANT AND LUBRICANT VAPOR OR MIST. Exposure may irritate eyes, nose, and throat. To remove R-12 or R-134a from the A/C system, use service equipment certified to meet the requirements of SAE-J2210 (R-12 or R-134a recycling equipment). If accidental system discharge occurs, ventilate the work area before resuming service. Use this equipment in locations with mechanical ventilation that provides at least four air changes per hour, or locate the equipment at least 18 inches above the floor.



R-12 or HFC-134a service equipment or vehicle A/C systems should not be pressure tested or leak tested with compressed air. Some mixtures of air/HFC-R-12 /R-134a have been shown to be combustible at elevated pressures. These mixtures are potentially dangerous and may result in fire or explosion causing injury or property damage.

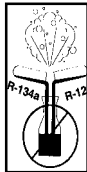

To prevent personal harm and equipment damage, make certain all safety devices are functioning correctly before operating the unit.

Use the Series 34800-2K/34801-2K only with R-12 or R-134a! Cross-contamination with other refrigerant types will cause severe damage to the A/C system and to service tools and equipment. Do not mix refrigerant types through a system or in the same container!

Additional health and safety information may be obtained from refrigerant and lubricant manufacturers.

OPERATING NOTES

At temperatures exceeding 120°F / 49°C, wait 10 minutes between recovery jobs.

U.S. Patents: 4,523,897; 4,688,388; Re 33,212; 4,768,347; 4,805,416; 4,809,520; 4,878,356; 4,938,031; 5,005,369; 5,005,375; 5,038,578; 5,042,271; 5,209,653; 5,248,125. Australian Patent: 613,058. Canadian Patents: 1,311,621; 1,311,622; 2,012,620; 2,026,348. European Patent: 0 315 296 Bl. German Patent: 031296. Mexican Patent: 16208
OTHER U.S. AND FOREIGN PATENTS PENDING.

Mfd. by Robinair, SPX Corporation, Owatonna, MN 55060

Table of Contents

Introduction	2
Glossary of Terms	2
Set-Up Instructions	4
Initial Set-Up	4
Operating Guidelines	6
Using the Selection Menu	6
Change Filter	6
Recycle	6
External Storage Vessel (ESV) Refill R-12	7
External Storage Vessel (ESV) Refill R-134a	8
Vacuum Oil Time	8
Filter Capacity	8
Basic/Advanced Prompts	9
Selecting a Unit (Metric/English)	9
Language Select	9
Using the Control Panel	10
Keypad Functions	11
Operating Instructions	12
Operating Tips	12
Recovering Refrigerant	13
Evacuating the A/C System	15
Replenishing A/C System Oil	18
Recharging the A/C System	19
Maintenance Instructions	21
Replacing the Filter-Drier	21
Changing the Vacuum Pump Oil	22
Checking for Leaks	23
Electrical Protection	24
General Maintenance	24
Replacement Parts List	24
Limited Warranty	Inside Back Cover

Introduction



WARNING! This manual contains important safety procedures concerning the operation, use, and maintenance of this product. Failure to follow the instructions contained in this manual may result in serious injury or death. If you are unable to understand any of the contents of this manual, please bring it to the attention of your supervisor. Do not operate this equipment unless you have read and have understood the contents of this manual.

The 34800-2K and the 34801-2K models are designed to be used on R-12 and R-134a vehicles. They are compatible with existing service equipment and standard service procedures.

The 34800-2K model is UL-listed. The 34801-2K is CE approved. Both are single-pass systems that meet the SAE specifications for recycled refrigerant.

To validate your warranty, complete the warranty card attached to your unit and return it within ten days from date of purchase.

GLOSSARY OF TERMS

- A/C System** The air conditioning system being serviced.
- Unit** The refrigerant recovery/recycling/recharging unit.
- External Storage Vessel** The refillable refrigerant storage vessel designed specifically for this unit.
- Source Tank** A disposable tank of new refrigerant used to refill the external storage vessel.

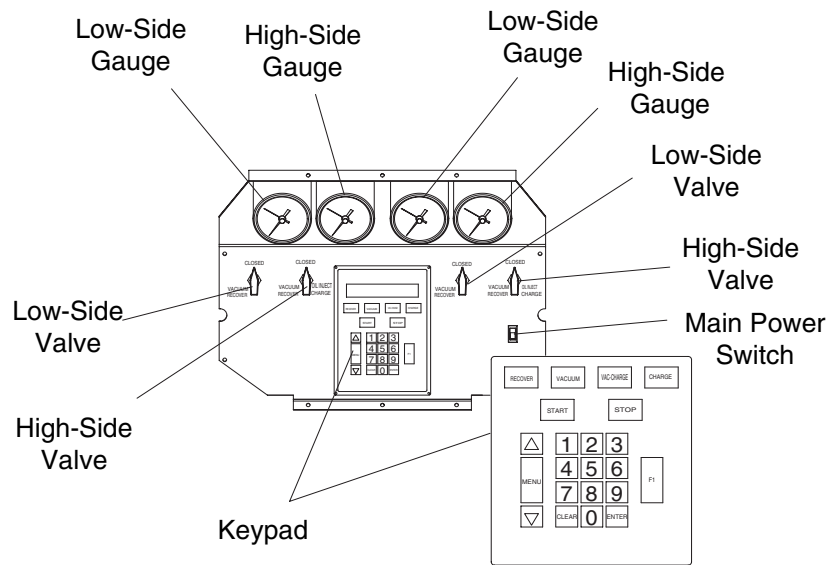
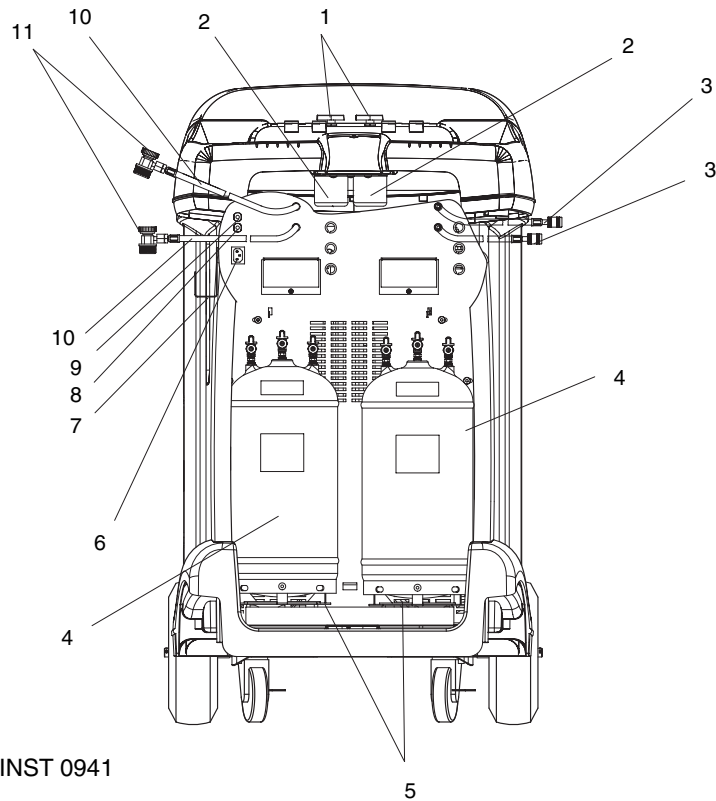

Diagram of the Control Panel

INST 0931

*Diagram of Unit's Components—
External View*



INST 0941

1. Oil Injection Valves
2. Oil Injection Bottles
3. R-12 Hoses
4. External Storage Vessel (ESV)
5. Scales
6. Power Cord Receptacle
7. Hose Holders
8. 3A Breaker (1.5A for 34801-2K)
9. 15A Breaker (7.5A for 34801-2K)
10. R-134a Hoses
11. Quick Couplers

*Diagram of Unit's Components—
Internal View*

1. Manifold Block
2. Vacuum Pump Receptacle
3. Accumulator
4. Oil Drain Bottle
5. Vacuum Pump
6. Fan
7. Compressor
8. Filter
9. Air Purge Assembly

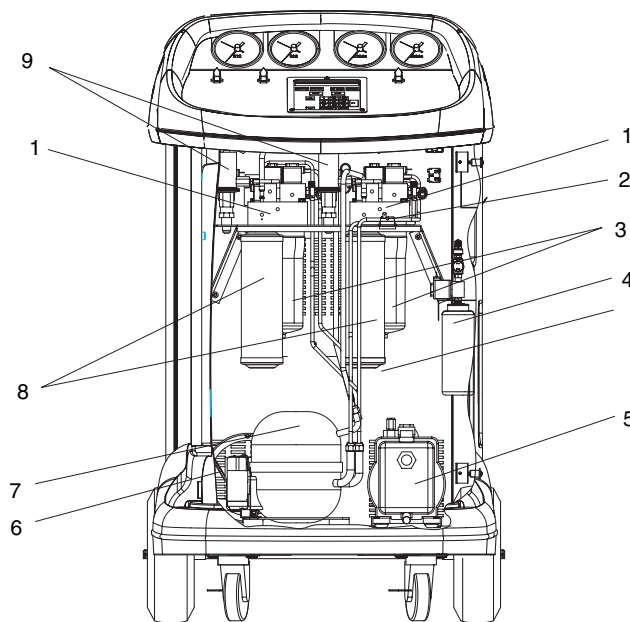

INST 0942

INITIAL SET-UP

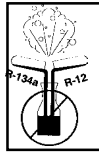

CAUTION!

R-134a systems have special fittings (per SAE specifications) to avoid cross-contamination with R-12 systems. Do not attempt to adapt your unit for another refrigerant — system failure will result! Read and follow all warnings at the beginning of this manual before operating the unit.



Avoid the use of an extension cord, because the extension cord may overheat. However, if you must use an extension cord, use a No. 14 AWG minimum and keep the cord as short as possible.

NOTE: Press the **MENU** key to access all functions, which are listed on page 6.

Before turning on the power:

1. Lock both front casters of the unit by stepping on the cam brake levers.
2. Plug the power cord into the power cord receptacle (Item 6 in the INST 0941 drawing on page 3).
3. Turn on the MAIN POWER switch.

The first time the unit is powered up, it will start in the initial setup mode.

Make the following selections:

1. Select a language.
 - a. Use the **UP** and **DOWN** arrow keys to select the desired language.
 - b. Press **START** to save the currently displayed language.
2. Select the operating units.
 - a. Toggle between UNITS ENGLISH and UNITS METRIC using the arrow keys.
 - b. Press **START** to save the currently displayed choice.
3. Toggle between BASIC/ADVANCED prompting procedures.
 - a. Use the arrow keys to make your selection.
 - Use the BASIC PROMPT option to receive step-by-step, on-screen prompting through any procedure.
 - Use ADVANCED PROMPT once you know the procedure and no longer need the step-by-step routine.
 - b. Press **START** to save the currently displayed choice.
4. Press **START** to begin the Oil Fill process.
 - a. Attach the flexible tube and cap to the oil bottle, and pour eight ounces of vacuum pump oil into the fill port.

IMPORTANT!

The vacuum pump is shipped without oil in the reservoir. To prevent damage to the pump, add oil before starting the pump.

Set-Up Instructions

- b. Press the **START** key. While the vacuum pump is running, slowly add oil until the level rises to the center of the reservoir's sight glass.
- c. Press the **STOP** key, and replace the black plastic plug on the fill port.
5. Use the **F1 (Mode)** key to switch between modes: R-12 and R-134a. Press **START** to continue. (After setting up the first mode, the unit will prompt you to set up the other mode.)
6. Connect the service hoses to the side that is being set up, turn both panel valves to **VACUUM/RECOVER**, and press **START**. The unit will automatically run a five-minute vacuum to clear all internal air.
7. After the vacuum is complete, connect the low-side service hose with adapter to a source tank. (For R-134a, use quick-coupler adapter No. 116121; for R-12, use the 6" yellow adapter No. 710778. Both are included with unit.)

NOTE: If using a refillable tank, install the tank upside down, and connect the low-side service hose to the vapor valve.

8. Open the tank valve and invert the tank. Press **START** when finished.
9. Press **START** to begin filling the external storage vessel.
10. The unit stops when a sufficient amount of refrigerant has been transferred to the internal tank or when the source tank is empty.
 - a. Press the **STOP** key to pause the process.
 - b. Press **STOP** again to exit, or **START** to resume.

This process takes 15–20 minutes.

NOTE: Add at least 8 lbs. (3.6 kg) of refrigerant before stopping the process to ensure enough refrigerant is available for charging.

11. When the fill process is complete, press **STOP** to exit.
12. Disconnect the source tank from the low-side service hose.

The first mode is now ready to use; you will be prompted to set up the remaining mode (R-134a or R-12). Select the other mode, and press **START**. Follow steps 5–12 for the other mode.

The unit is now ready to operate.

NOTE: There is no need to calibrate the scale; it is calibrated at the factory.

IMPORTANT!

For maximum performance, be sure to change the vacuum pump oil frequently.

Be sure the pump is running when adding oil.

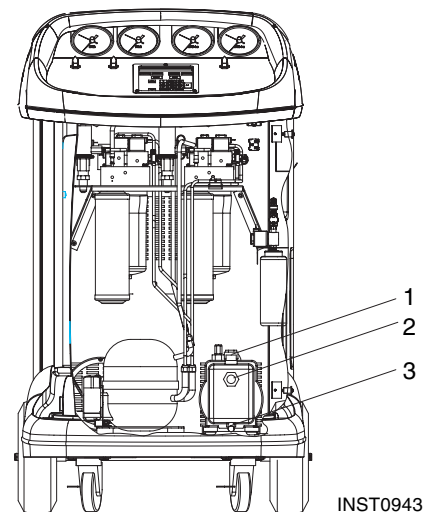

INST0943

1. Oil Fill Port
2. Sight Glass
3. Oil Drain

USING THE SELECTION MENU

The menu key provides a list of operating functions.

1. Press the **MENU** key. The top line of the display reads SET UP MENU.
2. Use the **UP** and **DOWN** arrow keys to scroll through the menu choices displayed on the second line. The menu choices are (in order of appearance):

1. SELECT LANGUAGE	7. VACUUM OIL TIME
2. SELECT UNITS (ENGLISH/METRIC)	8. CHANGE VACUUM PUMP OIL
3. TANK REFILL	9. SELECT PROMPTS
4. RECYCLE ONLY	10. CHANGE DEFAULTS
5. FILTER CAPACITY	(Password Protected)
6. CHANGE FILTER	11. VERSION X.XX
3. Press **START** to make a choice from the menu. Press **STOP** to pause any process, and **STOP** a second time to exit any process.

CHANGE FILTER

The filter-drier removes acid, particulates, and water from the refrigerant. Change the filter-drier after 150 pounds (68 kg) of refrigerant has been filtered. See “*Replacing the Filter-Drier*” on page 20 of the maintenance section of this manual.

RECYCLE

Manual recycling may be necessary, if excessive air and/or moisture is recovered from the A/C system.

1. Press the **MENU** key.
 - a. Use the arrow keys to scroll to RECYCLE ONLY.
 - b. Press **START** to accept the RECYCLE ONLY menu choice.
2. Press the **START** button again to start recycling.
 - To pause recycling, press the **STOP** key.
 - To terminate recycling, press the **STOP** key again.
 - To resume, press **START** key.

TANK REFILL (R-12)

NOTE: If using a refillable tank, place the tank upside down and connect the low-side service hose to the vapor valve.

Use the **F1 (Mode)** key to select **R-12 mode** (press and hold **F1** for several seconds to change modes).

1. Press the **MENU** key.
 - a. Use the arrow keys to scroll to **TANK REFILL**.
 - b. Press **START** to accept the menu choice.
2. Connect the 6" yellow adapter No. 710778 (included with unit) to the end of the low-side service hose.
3. Connect the low-side service hose with adapter to a source tank.
4. Open the tank valve and invert the tank.
5. Press the **START** key to automatically refill the tank. The unit stops when a sufficient amount of refrigerant has been transferred to the ESV, or if the source tank is empty.
 - a. Press the **STOP** key to pause the process.
 - b. Press **STOP** again to exit or **START** to resume before the external storage vessel is full.
6. When the fill process is complete, press **STOP** to exit.

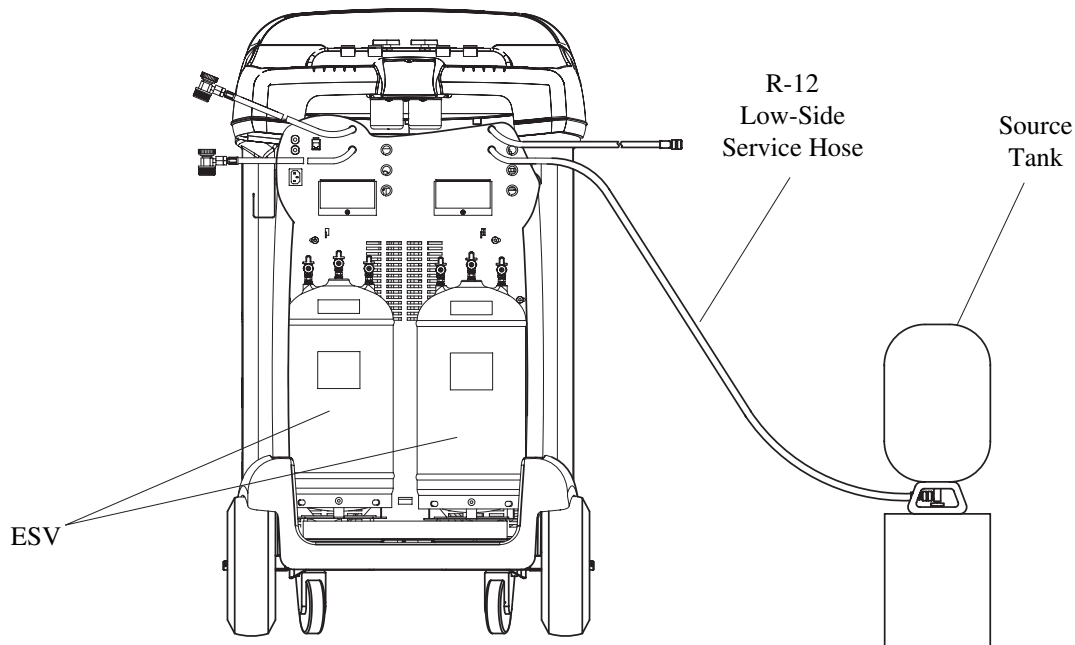

INST 0710

TANK REFILL (R-134a)

Use the **F1 (Mode)** key to select **R-134a** mode; press and hold **F1** for several seconds to change modes.

1. Press the **MENU** key.
 - a. Use the arrow keys to scroll to **TANK REFILL**.
 - b. Press **START** to accept the menu choice.
2. Connect the tank to quick-coupler adapter No. 116121 (included with unit) to the low-side service hose.
3. Connect the low-side hose with adapter to a source tank.
4. Open the tank valve and invert the tank.

NOTE: *If using a refillable tank, invert the tank, and connect the hose to the vapor valve.*

5. Press the **START** key to automatically refill the tank. The unit stops when a sufficient amount of refrigerant has been transferred to the internal tank, or if the source tank is empty.
 - a. Press the **STOP** key to pause the process.
 - b. Press **STOP** again to exit or **START** to resume before the internal tank is full.
6. When the fill process is complete, press **STOP** to exit.

VACUUM OIL TIME

This function displays how long the vacuum pump has run since the last oil change.

1. Press the **MENU** key.
 - a. Use the arrow keys to scroll to **VACUUM OIL TIME**.
 - b. Press **START** to accept menu choice.
2. The display reads: **OIL TIME = XX:XX**. This shows how long the pump has run since the last oil change. The time resets to zero after a vacuum pump oil change. See page 22 of this manual for details.
3. Press **STOP** to exit.

FILTER CAPACITY

This function is used to show the operator how many pounds of refrigerant have been recovered since the last filter change.

1. Press the **MENU** key.
 - a. Use the arrow keys to scroll to **FILTER CAPACITY**.
 - b. Press **START** to begin.
2. The display reads: **FILTERED= XXXlbs (kg)**. This shows how much refrigerant has passed through the filter. The amount filtered resets to zero after a filter change. See page 21 of this manual for details.

NOTE: *The displayed filter amount is for the mode the unit is currently operating in.*

3. Press **STOP** to exit.

SELECT PROMPT (BASIC/ADVANCED)

Use the BASIC PROMPT option to receive step-by-step, on-screen prompting through any procedure. Use ADVANCED PROMPT once you know the procedure and no longer need the step-by-step routine.

1. Press the **MENU** key.
 - a. Use the arrow keys to scroll to SELECT PROMPT.
 - b. Press **START** to accept the menu choice.
2. Use the arrow keys to toggle between BASIC and ADVANCED.
 - Use the BASIC PROMPT option to receive step-by-step, on-screen prompting through any procedure.
 - Use ADVANCED PROMPT once you know the procedure and no longer need the step-by-step routine.
3. Press the **START** to save the selected choice and exit.

NOTE: *This manual is written for the BASIC PROMPT option.*

SELECTING A UNIT (Metric/English)

1. Press the **MENU** key.
 - a. Use the arrow keys to scroll to SELECT UNITS.
 - b. Press **START** to accept the menu choice.
2. Use the arrow keys to toggle between UNITS ENGLISH and UNITS METRIC.
3. Press **START** to save the current choice and exit.

LANGUAGE SELECT

The operator can choose between English, Spanish, or French.

1. Press the **MENU** key.
 - a. Use the arrow keys to scroll to SELECT LANGUAGE.
 - b. Press **START** to accept the menu choice.
2. Use the **UP** and **DOWN** arrows to scroll through the languages.
3. Press **START** to save the current choice, or press **STOP** to exit without saving.

CHANGE DEFAULTS

For service use only.

VERSION

Displays the current software revision.

USING THE CONTROL PANEL

The control panel has various components that control specific operating functions.

MAIN POWER SWITCH — Supplies electrical power to the control panel.

DIGITAL DISPLAY — Used on the visual interface between the operator and the machine.

LOW-SIDE MANIFOLD GAUGE — Connects to an A/C system, and shows the system's low-side pressure.

HIGH-SIDE MANIFOLD GAUGE — Connects to an A/C system, and shows the system's high-side pressure.

LOW-SIDE VALVE — Controls the low-side flow from the A/C system through the unit. It has two positions: 1) VACUUM/RECOVER and 2) CLOSED.

HIGH-SIDE VALVE — Controls the high-side flow from the A/C system through the unit. It has three positions: 1) VACUUM/RECOVER, 2) CLOSED, and 3) OIL INJECT/CHARGE.

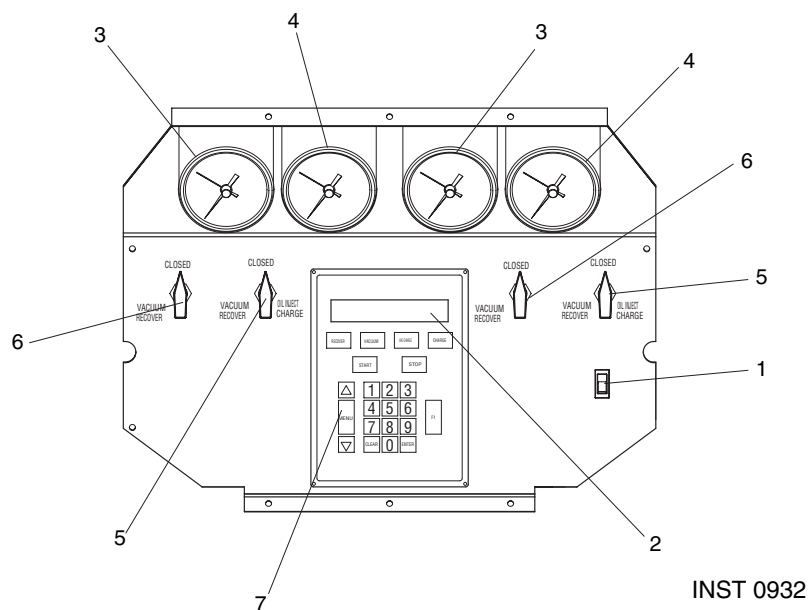

Diagram of Control Panel

- | | |
|----------------------|--------------------|
| 1. Main Power Switch | 5. High-Side Valve |
| 2. Display | 6. Low-Side Valve |
| 3. Low-Side Gauge | 7. Keypad |
| 4. High-Side Gauge | |

KEYPAD FUNCTIONS

In addition to the number keys, the keypad contains special keys that accomplish specific operating functions.

- **START**—Begins or resumes a function.
- **STOP**—Terminates or pauses a function.
- **RECOVER**—Activates the recovery sequence.
- **VACUUM**—Activates the vacuum and automatic recycling sequence.
- **VAC-CHARGE**—Activates the vacuum and automatic recycling sequence followed by a charge.
- **CHARGE**—Charges the A/C system with a programmed amount of refrigerant.
- **MENU**—Enters the selection menu.
- **UP/DOWN ARROWS**—Used for scrolling through the menu items.
- **CLEAR**—Factory use only.
- **ENTER**—Factory use only.
- **F1 (Mode)** —Press and hold to select the operating mode (R-12 or R-134a).

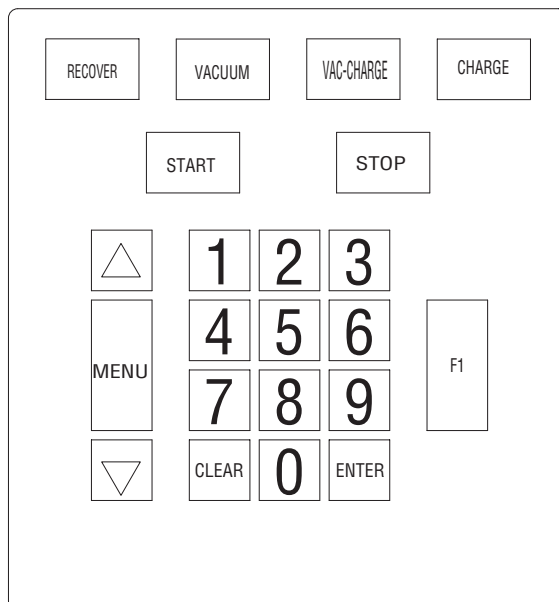

INST 0933

Diagram of Keypad

OPERATING TIPS

Follow the recommended service procedure for the containment of R-12 and R-134a refrigerants.

The recovery compressor is *not* a vacuum pump. The compressor pulls the A/C system to a partial vacuum only. Use the unit's vacuum cycle to remove moisture from the A/C system. We recommend a minimum 15-minute vacuum with more time as required by the system manufacturer.

This unit is designed to be used with the manifold gauge set built into the control panel.

It includes a 6 cfm (142 l/m) vacuum pump for fast, thorough evacuation. It is important to change the vacuum pump oil after 10 hours of vacuum pump use.

R-12 and R-134a systems require special oils. Refer to the A/C system manufacturer's service manuals for oil specifications.

Pressing the **START** and **STOP** keys together for several seconds will exit any mode and reset the control.

NOTE: *The following operating instructions are written to be used with the BASIC PROMPTS mode of operation. It is recommended that the BASIC PROMPTS mode be used until the operator becomes very familiar with the operation of the unit. See the OPERATING GUIDELINES section of this manual for instructions on how to select BASIC PROMPTS or ADVANCED PROMPTS.*

RECOVERING REFRIGERANT



WARNING



Wear safety goggles when working with refrigerant. Read and follow all warnings at the beginning of this manual before operating the unit.

1. Connect the power cord to the back of the unit, and plug into the correct voltage outlet.
2. Turn on the MAIN POWER, and if necessary, empty the oil drain bottle located on the right hand side of the unit.
3. Verify the unit is in the appropriate refrigerant mode. Use the **F1 (Mode)** key to select the correct refrigerant mode.
4. Press the **RECOVER** button.
5. If 150 pounds (68 kg) or more of refrigerant has been recovered since the last filter-drier change, the display reads FILTER WEIGHT XXX lb (XX kg). Press **START** to continue, **STOP** to exit.

NOTE: See the filter change procedure on page 21 of this manual for details on replacing the filter.

6. Connect the high- and low-side hoses to the A/C system, and on R-134a systems, open the coupler valves.
7. Put the low-side valve in the VACUUM/RECOVER position. Put the high-side valve in the VACUUM/RECOVER position. Press **START** to continue.
8. If the system pressure is below 25 psi, the display reads LOW SYSTEM PRESSURE until the pressure increases (verify panel valves and coupler valves are connected correctly); or the **START** button is pressed (pressing **START** at this time bypasses the Low System Pressure and goes into recovery); or you may press **STOP** to exit at this point.

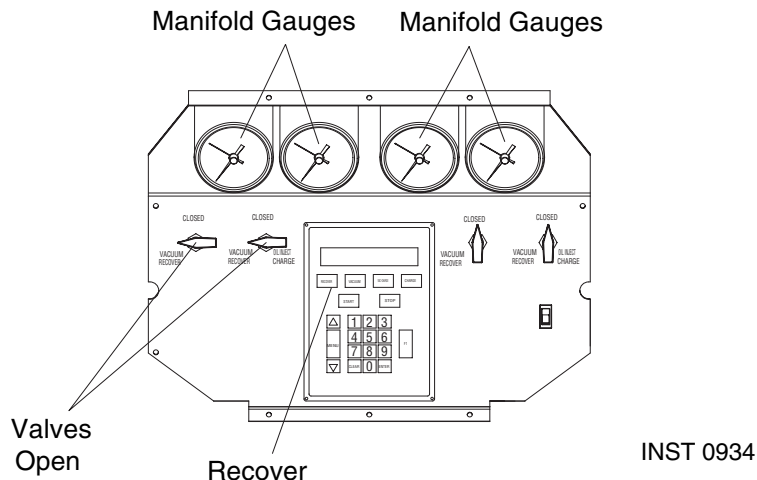

Diagram of Control Panel During Recovery

Operating Instructions

9. If the unit has refrigerant in the low-side plumbing, it begins the clearing process and displays **CLEARING IN PROGRESS**. If you wish to skip the clearing operation or stop the clearing prematurely, press the **STOP** key.
10. When the system has recovered to a vacuum level of approximately 13 in. Hg., the compressor automatically shuts off.
11. The unit then goes into automatic oil drain and the display reads: **OIL DRAINING**. Oil draining can require up to 90 seconds to complete.
12. After the oil drain is complete, the display alternates between:

RECOVERY COMPLETE
RECOVERED XX.XX lbs. (X.XXkg)

and

CHECK OIL BOTTLE.
RECOVERED XX.XX lbs. (X.XXkg)

NOTE: *The displayed recovered weight can vary, depending on ambient conditions, and should not be used as an indicator of scale accuracy.*

13. Check the oil drain bottle, and note the amount of oil that was removed from the A/C system. This is the amount of oil that must be charged into the A/C system after evacuation is complete.
14. To ensure complete recovery of refrigerant, wait 5 minutes and watch the manifold gauges for a rise in pressure above 0 in. Hg. A pressure rise may occur if there was freezing in the A/C system during recovery. If a rise occurs, press the **START** button to resume the recovery process. Repeat as needed until the system pressure holds for two minutes, then press **STOP** to exit.

Recovery is now complete. You are now ready to make any repairs to the A/C system, if necessary, or advance to the Evacuation Process.

Diagram of the Oil Injection System

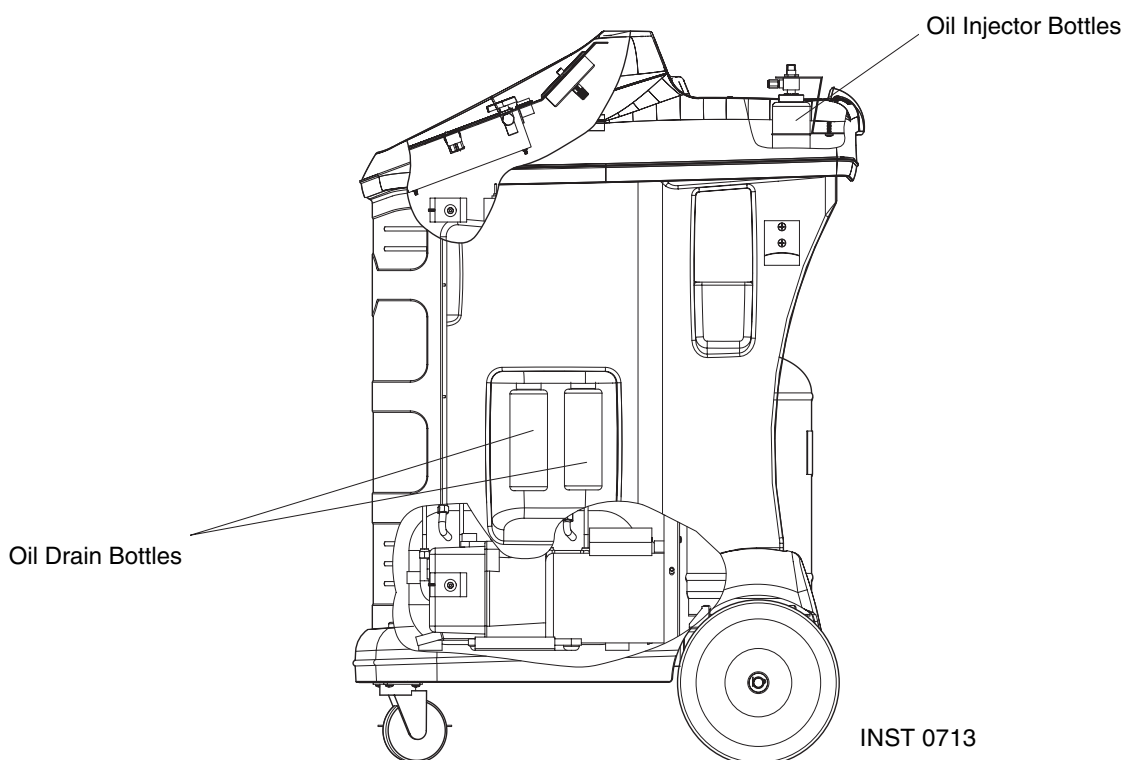

INST 0713

EVACUATING THE A/C SYSTEM



WARNING



Wear safety goggles when working with refrigerant. Use only authorized refillable refrigerant tanks. Read and follow all warnings at the beginning of this manual before operating the unit.

NOTES:

- If any oil was drained from the system during recovery, **DO NOT** use the VAC-CHARGE feature. The oil must be replenished into the A/C system, which is not possible when the VAC-CHARGE function is used.
- If the vacuum pump has been run more than 10 hours since the last oil change, the display reads: VACUUM OIL TIME XX:XX. Press the **STOP** key to change the vacuum pump oil; or press the **START** key to continue. See “Maintenance Instructions” for changing the vacuum pump oil.
- If the system being evacuated contains a pressure over 25 psi at any point during the evacuation, the display reads PRESSURE EXISTS. This message indicates that the A/C system contains refrigerant; press any key to continue. Press the **RECOVERY** key to recover any refrigerant in the system (see “Recovering Refrigerant” on page 13). After recovery is complete, use the steps on the next page to evacuate the A/C system.

IMPORTANT!

You should evacuate for at least 15 minutes to ensure adequate moisture and contaminant removal.

Vacuum pump oil should be changed after 10 hours of use for maximum performance and endurance levels.

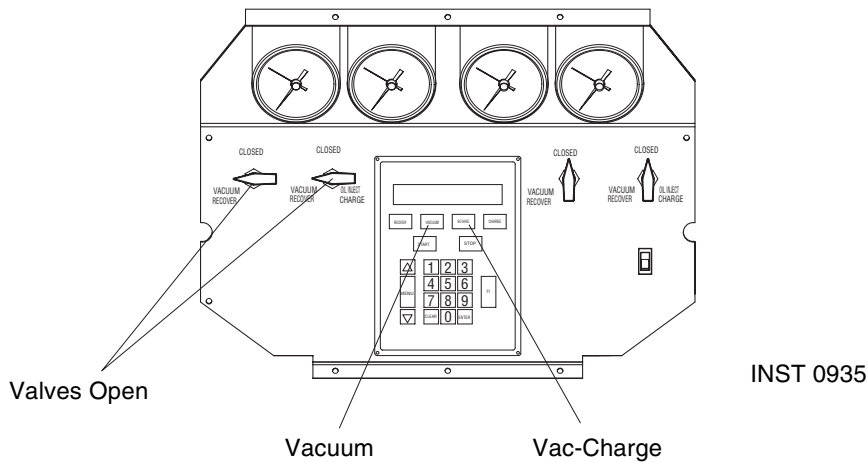

The Control Panel During Evacuation

VAC-CHARGE

NOTE: Verify unit is in the correct refrigerant mode. Use the **F1 (Mode)** key to select the appropriate refrigerant mode.

1. Press the **VAC-CHARGE** key to select the VAC-CHARGE feature.
2. Verify service hoses are connected and panel valves are in the VACUUM/RECOVER position. Press **START**
3. Press the **START** key to charge the default amount of refrigerant, or use the number keys to enter the desired charge weight. Then press the **START** key.
4. If the weight entered will leave less than 3 lbs. (1.36 kg) of refrigerant in the external storage vessel, the vac-charge process does not begin, and the display reads INSUFFICIENT REFRIG. At this point, refrigerant must be added to the external storage vessel. See pages 7 and 8 of this manual for external storage vessel refill instructions, and then return to Step 1 above.
5. If the external storage vessel contains a sufficient amount of refrigerant, press the **START** key to accept the default evacuation time of 15:00 minutes, or enter the desired vacuum time by using the number keys. Then press the **START** key.
6. The unit automatically charges the A/C system 10 seconds after the specified vacuum time has elapsed.
7. Upon entering a valid charge weight, the display reads:

CHARGE IN PROGRESS
CHARGED= X.XX lbs. (X.XX kg)
8. If, during the charge cycle, the weight fails to charge 0.05 lbs. (0.02 kg) in 30 seconds, the unit intermittently beeps while the bottom line on the display scrolls:

CHARGE HAS SLOWED
PRESS START TO RETRY OR STOP TO EXIT
9. Pressing the **START** key when the charging is slowed causes the charge to resume. If charging does not complete, see the “Slow Charge Procedure” on the next page.
10. When the charge is complete, the display will show

CHARGE COMPLETE
X.XXlb (kg) CHARGED
11. For an R-134a system close the high- and low-side coupler valves. Remove the service hoses from the A/C system.

IMPORTANT!

You should evacuate the A/C system for at least 15 minutes to ensure adequate moisture and contaminant removal.

VACUUM

NOTE: Ensure the unit is in the correct refrigerant mode. Use the **F1 (Mode)** key to select the appropriate refrigerant mode.

1. Press the **VACUUM** key.
2. Ensure the service hoses are connected and panel valves are in the **VACUUM/RECOVER** position. Press **START**.
3. Press the **START** key to accept the default evacuation time of 15:00 minutes, or enter the desired vacuum time by using the number keys, and press the **START** key.
4. The unit evacuates the A/C system and stops when the specified time has elapsed. Pressing the **STOP** key will pause the process. Press **START** to resume or **STOP** again to exit.
5. You are now ready to replenish the A/C system oil, if necessary, or advance to Recharging the A/C System.

REPLENISHING A/C SYSTEM OIL

Before charging the A/C system, you must replenish any oil removed from the A/C system during the recovery process.

1. Select the correct oil for the A/C system being serviced. Refer to the vehicle manufacturer's service manual.

CAUTION! To prevent air from entering the A/C system, never let the oil level drop below the pick-up tube while charging or replenishing.

2. Adjust the o-ring around the oil injector bottle to the required oil charge level. For example, if the bottle's oil level is at 4 ounces, and you need 1/2 ounce of oil to replenish the A/C system, place the o-ring at the 3-1/2 ounce level.
3. Install the bottle to the oil injection assembly on the back of the unit.

CAUTION! Never open the oil injection valve while there is positive pressure in the A/C system. This action could blow oil back through the bottle vent.

4. Place the low-side valve in the Closed position. Place the high-side valve in the Oil Inject/Charge position.
5. Turn the oil injection valve at the top of the bottle, and watch the level of oil being drawn into the A/C system. This process takes only seconds—watch carefully!
6. Turn OFF the valve when the required oil charge has been pulled into the system.

CAUTION! Perform a charge after any oil inject to ensure all of the oil is delivered to the A/C system.

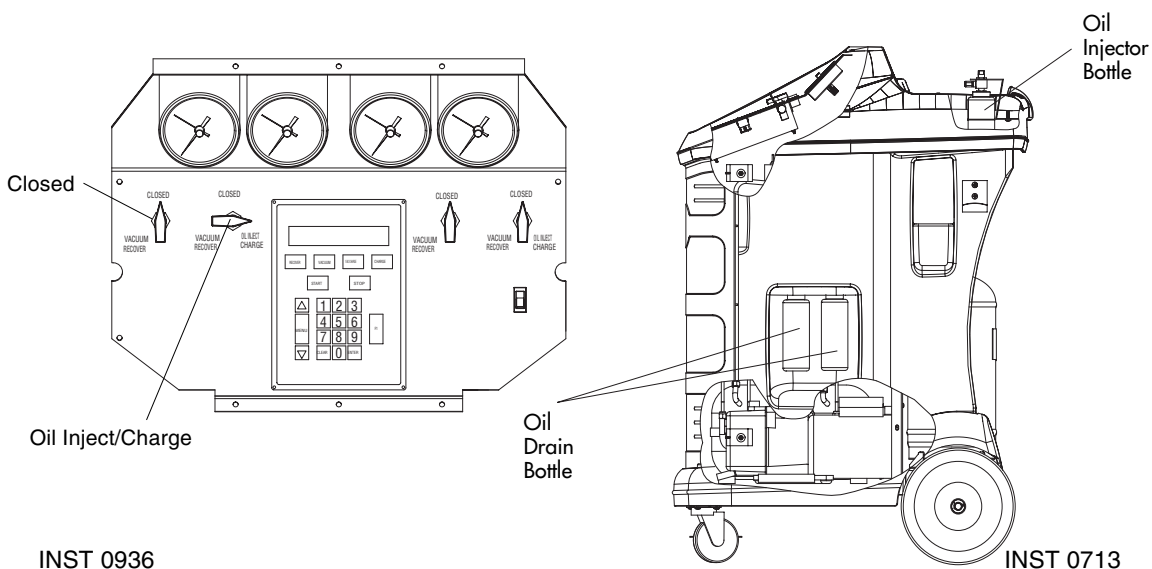

RECHARGING THE A/C SYSTEM

! WARNING !



Wear safety goggles when working with refrigerant. Use only authorized refillable refrigerant tanks. Disconnect hoses with extreme caution! All hoses may contain liquid refrigerant under pressure. Read and follow all warnings at the beginning of this manual before operating the unit.



NOTE: Verify unit is in the correct refrigerant mode. Use the **F1 (Mode)** key to select the appropriate refrigerant mode.

1. Press the **CHARGE** button.
2. Put the low-side valve in the Closed position. Put the high-side valve in the Oil Inject/Charge position. Press **START** to continue
3. Accept either the default weight by pressing **START**, or type in a weight with the number keys, and press **START**.

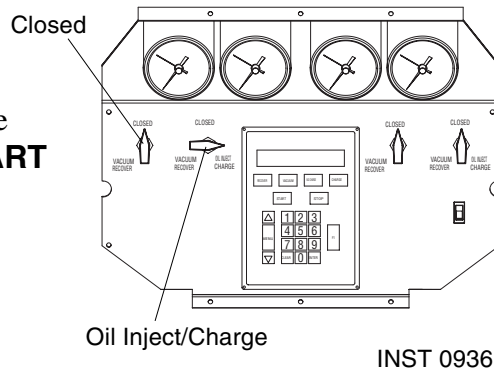

4. If the weight entered will leave less than 3 lbs. (1.36 kg) of refrigerant in the external storage vessel, the charge function will not start and the display reads:

INSUFFICIENT REFRIG.
PRESS ANY KEY TO EXIT

See the Operating Guidelines section of the manual for refill instructions.

5. Upon entering a valid charge weight, the display reads:

CHARGE IN PROGRESS
CHARGED= X.XX lbs. (X.XX kg)

6. If, during the charge cycle, the weight fails to charge 0.05 lbs. (0.02 kg) in 30 seconds, the unit intermittently beeps while the bottom line on the display scrolls:

CHARGE HAS SLOWED
PRESS START TO RETRY OR STOP TO EXIT

7. Pressing the **START** key when the charging is slowed causes the charge to resume. If charging does not complete, see the “Slow Charge Procedure” on the next page.

IMPORTANT!

Evacuate the A/C system for at least 15 minutes for adequate moisture and contaminant removal.

Operating Instructions

8. When the charge is complete, the display will show

CHARGE COMPLETE
X.XXlb (kg) CHARGED

9. Close the high- and low-side coupler valves (R-134a systems only).
10. Remove the service hoses from the A/C system.

The A/C system is now ready for use.

SLOW CHARGE PROCEDURE

! WARNING !



Before starting the vehicle's engine, check to see that it is in "park" or "neutral," with the emergency brake ON. Never run a vehicle without adequate ventilation in the work area.

1. Close the high-side valve. Put the low-side valve in the VACUUM/RECOVER position.
2. Start the vehicle and set the AC system to its maximum setting.
3. Press **START**. The unit charges out of the low-side inlet only, allowing the vehicle's compressor to pull the refrigerant into the A/C system.
4. When the unit is finished charging, the display reads:

CHARGE COMPLETE
X.XX lbs. (kg) CHARGED

5. Close the low-side manifold valve.
6. Turn off the vehicle's engine.
7. Close the high- and low-side coupler valves (R-134a systems only).
8. Remove the service hoses from the A/C system.

The A/C system is now ready for use.

REPLACING THE FILTER-DRIER

Order part #34724 for a replacement filter-drier. The filter-drier on this unit is designed to trap acid and particulates, and is formulated to remove water from the refrigerant. You must change the filter-drier to ensure adequate moisture and contaminant removal.

Typically, you can recycle up to 150 pounds (68 kilograms) of refrigerant between filter changes.

CAUTION! For best results, use Robinair filter-driers (part no. 34724). All performance tests and claims are based on using this specially-blended filter-drier; use of another may affect performance results.

1. Press the **MENU** button.
2. Scroll through the menu to **CHANGE FILTER**, and press **START** to accept the menu choice.
3. Press **START** again to begin clearing the filter.
4. When clearing is complete, the display reads **TURN UNIT OFF AND REPLACE FILTER**.
5. Turn off the main power and unplug the machine.
6. Open the unit door, and replace the old filter with the new filter.
7. Close the unit door, plug in the machine, and turn on the main power switch.
8. The filter change is now complete.



INST 0478

Filter-Drier

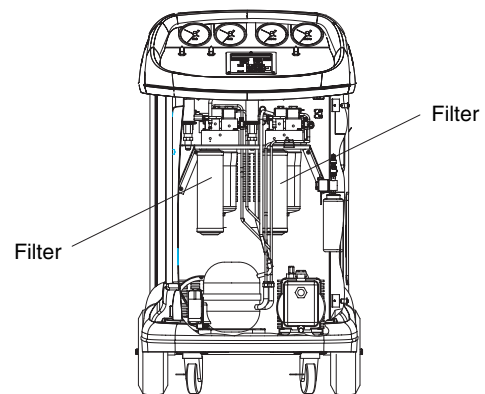

INST 0944

Location of the Filter-Drier

CHANGING THE VACUUM PUMP OIL

For maximum vacuum pump performance, change the vacuum pump oil after every 10 hours of operation.

IMPORTANT!

Review current local, state, and federal statutes, cases, laws, and regulations to determine the current status and appropriate disposal method for pump oil. It is the responsibility of the user to determine if a material is a hazardous waste at the time of disposal. Ensure you are in compliance with all applicable laws and regulations.

1. Turn on the **MAIN POWER** switch.
2. Press the **MENU** button.

NOTE: Do *NOT* connect service hoses to a vehicle.

3. Use the arrow keys to select **CHANGE VACUUM PUMP OIL**, and press **START**.
4. Press **START** again to begin.
5. The vacuum pump will run for two minutes. Allow the vacuum pump to run until it automatically stops.
6. Remove the black plastic plug on the oil fill port of the vacuum pump.
7. Remove the oil drain cap from the vacuum pump, and drain the oil into a suitable container for proper disposal.
8. Replace the oil drain cap.
9. Attach the flexible tube and cap to the oil bottle, and pour eight ounces of vacuum pump oil into the fill port.
10. Press the **START** key. While the vacuum pump is running, slowly add oil until the level rises to the center of the reservoir's sight glass.
11. Press the **STOP** key, and replace the black plastic plug on the fill port.
12. The unit is now ready to operate.

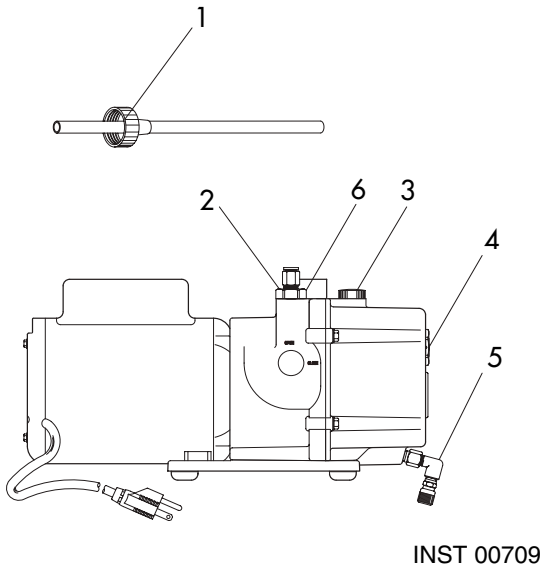

INST 00709

Diagram of Vacuum Pump

1. Oil Filler Tube
2. Pump Exhaust
3. Oil Fill Port
4. Sight Glass
5. Oil Drain Fitting
6. Inlet

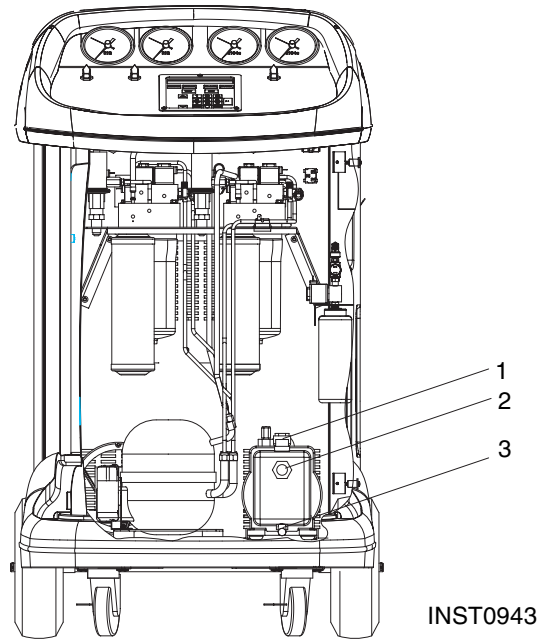

INST0943

1. Oil Fill Port
2. Sight Glass
3. Oil Drain

CHECKING FOR LEAKS

Every three months, or as specified by local or state laws, check the unit for leaks.

1. Turn off the MAIN POWER switch, and disconnect the power cord from the outlet.
2. Open the door.
3. Use a leak detector to probe all connections for refrigerant leaks. Tighten fittings if a leak is indicated.
4. Close the door.

IMPORTANT!

Inspect the unit periodically for leaks. The manufacturer does not reimburse for lost refrigerant.

ELECTRICAL PROTECTION

If the circuit breaker trips, all power to the unit is lost. Press the circuit breaker button to reset. The circuit breaker is located near the fuse on the back of the unit.

GENERAL MAINTENANCE

1. On a regular basis, wipe off the unit with a clean cloth to remove grease, dust, or other dirt.
2. Periodically check the internal components for leaks—over time, fittings can loosen as the unit is moved. Open the unit door panel, and trace lines with a leak detector. Also, check connections on the back of the unit. Tighten any loose fittings or connections.

REPLACEMENT PARTS

The following is a list of replacement parts and accessories needed to service or maintain your unit.

We suggest you keep several filter-driers on hand so you will always be able to change them and complete any recycling job that is in progress.

Premium High Vacuum Pump Oil is also available in handy quart containers or in convenient gallon containers:

Quart (shipped 12 quarts per case) 13203

Gallon (shipped 4 gallons per case) 13204

34800-2K/34801-2K Replacement Parts

Component	R-12 Replacement Part Number	R-134a Replacement Part Number
96" Red Hose	68396A	63096
96" Blue Hose	68296A	62096
Filter-Drier	34724	34724
Low Side Coupler	N/A	18190A
High Side Coupler	N/A	18191A
Maintenance Kit	13172	13172

Robinair Limited Warranty Statement

Rev. November 1, 2005

This product is warranted to be free from defects in workmanship, materials, and components for a period of one year from date of purchase. All parts and labor required to repair defective products covered under the warranty will be at no charge. The following restrictions apply:

1. The limited warranty applies to the original purchaser only.
2. The warranty applies to the product in normal usage situations only, as described in the Operating Manual. The product must be serviced and maintained as specified.
3. If the product fails, it will be repaired or replaced at the option of the manufacturer.
4. Transportation charges for warranty service will be reimbursed by the factory upon verification of the warranty claim and submission of a freight bill for normal ground service. Approval from the manufacturer must be obtained prior to shipping to an authorized service center.
5. Warranty service claims are subject to authorized inspection for product defect(s).
6. The manufacturer shall not be responsible for any additional costs associated with a product failure including, but not limited to, loss of work time, loss of refrigerant, cross-contamination of refrigerant, and unauthorized shipping and/or labor charges.
7. All warranty service claims must be made within the specified warranty period. Proof-of-purchase date must be supplied to the manufacturer.
8. Use of recovery/recycling equipment with unauthorized refrigerants or sealants will void warranty.
 - Authorized refrigerants are listed on the equipment or are available through the Technical Service Department.
 - The manufacturer prohibits the use of the recovery/recycling equipment on air conditioning (A/C) systems containing leak sealants, either of a seal-swelling or aerobic nature.

This Limited Warranty does NOT apply if:

- The product, or product part, is broken by accident.
- The product is misused, tampered with, or modified.
- The product is used for recovering or recycling any substance other than the specified refrigerant type. This includes, but is not limited to, materials and chemicals used to seal leaks in A/C systems.

CONVERSION TABLE

OZ.	LBS.
0.5	0.03
1.0	0.06
1.5	0.09
2.0	0.13
2.5	0.16
3.0	0.19
3.5	0.22
4.0	0.25
4.5	0.28
5.0	0.31
5.5	0.34
6.0	0.38
6.5	0.41
7.0	0.44
7.5	0.47
8.0	0.50
8.5	0.53
9.0	0.56
9.5	0.59
10.0	0.63
10.5	0.66
11.0	0.69
11.5	0.72
12.0	0.75
12.5	0.78
13.0	0.81
13.5	0.84
14.0	0.88
14.5	0.91
15.0	0.94
15.5	0.97
16.0	1 lb.



Visit our web site at
www.robinair.com

or call our Toll-Free

**Technical Support Line at
800-822-5561**

in the continental U.S. or Canada.

In all other locations, contact your local distributor. To help us serve you better, please be prepared to provide the model number, serial number, and date of purchase of your unit.

To validate your warranty, complete the warranty card attached to your unit, and return it within ten days from date of purchase.

- **NATIONWIDE NETWORK OF AUTHORIZED SERVICE CENTERS**

If your unit needs repairs or replacement parts, contact the service center in your area. For help in locating a service center, call the toll free technical support line.

Due to ongoing product improvements, we reserve the right to change design, specifications, and materials without notice.

The 34800-2K and 34801-2K are designed to meet all applicable agency certifications including Underwriter's Laboratories, Inc., SAE Standards and CUL. Proper maintenance of this equipment will provide accurate A/C service for many years.

Certain state and local jurisdictions dictate that using this equipment to sell refrigerant by weight may not be permitted. We recommend charging for any A/C service by the job performed.

This weight scale provides a means of metering the amount of refrigerant needed for optimum A/C system performance as recommended by OEM manufacturers.

SPX

ROBINAIR

*SPX Corporation
655 Eisenhower Drive
Owatonna, MN 55060-0995 USA
Tech Services: 1-800-822-5561
Fax: 1-412-690-2001
Customer Service: 1-800-533-6127
Fax: 1-800-322-2890
Web site: www.robinair.com*