

Air Tools

Impact Wrenches | Sanders | Air Ratchets | Tire Buffers
Grinders | Drills | Air Hammers | Finishing Tools
Cordless Tools | Air Tool Accessories | Work Stations



Advanced Wheel Solutions

One-Stop-Shop for all your Tire Changing Needs!



People.
Passion.
Performance.



Chicago
Pneumatic

WORLD'S FIRST CORDLESS 1" D-HANDLE IMPACT WRENCH



M18 FUEL™

DRIVEN TO OUTPERFORM.™

M18 FUEL™ is engineered for the most demanding diesel technicians in the world. M18 FUEL™ delivers unrivalled performance in a compact structure and features three MILWAUKEE® exclusive innovations — the POWERSTATE™ Brushless Motor, REDLITHIUM™ Battery Pack and REDLINK PLUS™ Intelligence Hardware and Software — that deliver unmatched power, run-time and durability. Simply put, M18 FUEL™ is best-in-class, full-circle technology that drives, protects and powers your cordless power tools beyond the rest.

1 POWERSTATE™ BRUSHLESS MOTOR

2 REDLINK PLUS™ INTELLIGENCE

3 REDLITHIUM™ HIGH OUTPUT™ HD12.0

50% MORE POWER & RUNS COOLER
VS REDLITHIUM™ HD

FITS M18™ TOOLS

milwaukeeetool.com

M18 FUEL™ 1" D-Handle
Extended Anvil High Torque
Impact Wrench w/ ONE-KEY™ Kit
2869-22HD

COMING EARLY Q4 2020

M18

PERFORMANCE DRIVEN
TRADE FOCUSED
SYSTEM WIDE





2135TiMAX-2



2145QiMAX



231HA-2

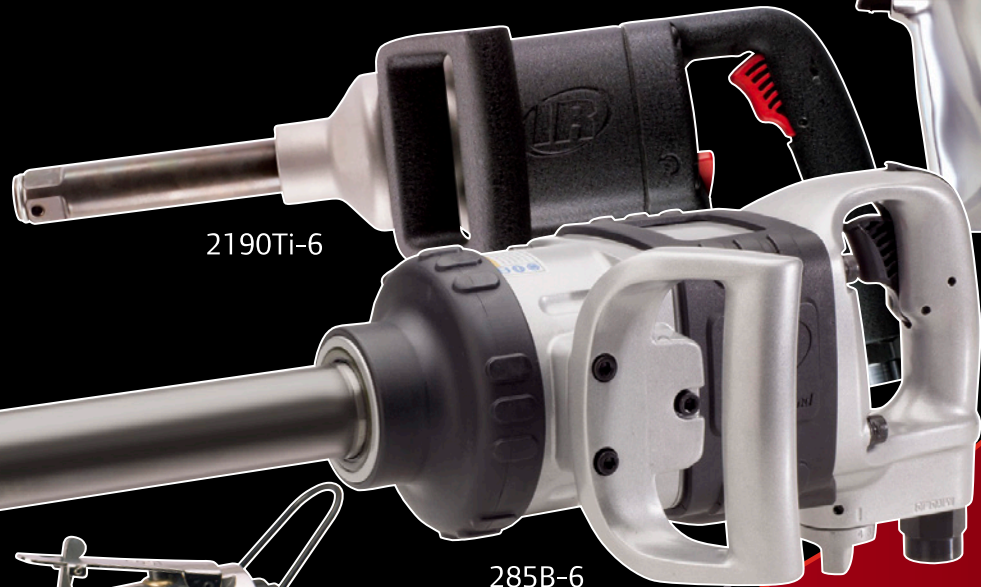

2190Ti-6

285B-6



327LS

Ingersoll Rand Tough Tools for Tough Jobs

Impact Wrenches (CP)



QUICK REFERENCE CHART

CP No.	Ascot No.	Sq. Drive (mm)	Std Bolt Size (mm)	Net Weight lb. (kg)	Average Air Cons. (cfm)	Air Inlet (NPTF)	Min. Hose Size	Working Torque Range ft./lb. (NM)	Max Torque ft./lb. (NM)
CP7722	152-07722	3/8" (10)	3/8" (10)	2.09 (0.95)		1/4"	1/4"	5-65 (7-88)	90 (120)
CP724H	152-00724	3/8" (10)	3/8" (10)	3.1	1.7	1/4"	3/8"	68 - 190 (92 - 257)	200 (271)
CP7727	152-07727	3/8" (10)	3/8" (10)	2.5 (1.12)	4	1/4"	3/8"	20-142(26-192)	185 (250)
CP7729	152-07729	3/8" (10)	3/8" (10)	2.78 (1.25)	5	1/4"	3/8"	50-300 (68-407)	415 (563)
CP734H	153-00734	1/2" (13)	9/16" (15)	5.1 (2.31)	3.75	1/4"	3/8"	25-310 (34-420)	425 (576)
CP7736	153-00736	1/2" (13)	9/16" (15)	5.70 (2.58)	4.4	1/4"	3/8"	51-568(69-770)	665 (901)
CP7736-2	153-07336	1/2" (13)	9/16" (15)	6.5 (2.9)	4.4	1/4"	3/8"	51-568(69-770)	665 (901)
CP7737	153-07737	1/2" (13)	9/16" (15)	2.5 (1.13)	4	1/4"	3/8"	25-165 (34-224)	220 (300)
CP7748	153-07748	1/2" (13)	9/16" (15)	4.6 (2)	6.2	1/4"	3/8"	75-580 (102-786)	960 (1300)
CP7748-2	153-77482	1/2" (13)	9/16" (15)	5.1 (2.4)	6.2	1/4"	3/8"	75-580 (102-786)	960 (1300)
CP749	153-07492	1/2" (13)	5/8" (16)	5.25 (2.5)	5.5	1/4"	3/8"	50-450 (68-610)	610 (827)
CP749-2	156-07992	1/2" (13)	5/8" (16)	5.5 (2.5)	5.75	1/4"	3/8"	50-450 (68-610)	610 (827)
CP7640-6	155-07640	1/2" (13)	5/8" (16)	25.55 (11.6)	4.8	1/2"	1/2"	370 - 1475 (500 - 2000)	1920 (2600)
CP7749	153-07749	1/2" (13)	5/8" (16)	4.37 (1.98)	4.8	1/4"	3/8"	75-580 (102-428)	955 (1295)
CP7749-2	153-77492	1/2" (13)	5/8" (16)	4.5 2.04	4.8	1/4"	3/8"	75-580 (102-428)	955 (1295)
CP772H	154-00772	3/4" (18)	1-1/8" (28)	10.1 (4.8)	6	3/8"	1/2"	150-700 (203-949)	1000 (1356)
CP772H-6	154-01772	3/4" (18)	1-1/8" (28)	11.63 (5.28)	6	3/8"	1/2"	150-700 (203-949)	1000 (1356)
CP7763D	154-27763	3/4" (18)	1-1/8" (28)	14.3 (6.5)	41	1/2"	3/8"	250-1070 (340-1450)	1300 (1760)
CP7763D-6	154-37763	3/4" (18)	1-1/8" (28)	16.1 (7.3)	42	1/2"	3/8"	250-1070 (340-1450)	1300 (1760)
CP7769	154-07769	3/4" (18)	1-1/8" (28)	6.9 (3.15)	4.8	3/8"	1/2"	300 - 1080 (407 - 1464)	1140 (1950)
CP7769-6	154-77696	3/4" (18)	1-1/8" (28)	8.3 (3.75)	4.7	3/8"	1/2"	300 - 1080 (407 - 1464)	1140 (1950)
CP7773D	155-07773	1" Square	1-1/4" (32)	12.1 (5.5)	10.5	3/8"	1/2"	250-1070 (340-1450)	1300 (1760)
CP7773D-6	155-77736	1" Sq. 6" Ext	1-1/4" (32)	16.3 (7.4)	10.5	3/8"	1/2"	250-1070 (340-1450)	1300 (1760)
CP7778	155-07778	1" Square	1-1/4" (32)	22.5 (10.1)	8.7	1/2"	1/2"	100-1100 (136-1491)	1620 (2196)
CP7778SP-6	155-27786	1" Square	1-1/4" (32)	25.4	4.1	1/2"	1/2"	300 - 1,330 (400-1800)	1620 (2200)
CP7782	155-07782	1" Short Anvil	1-1/4" (32)	22.2 (10.1)	4.8	1/2"	1/2"	370 - 1475 (500 - 2000)	1920 (2603)
CP7782-6	155-77786	1" Sq. 6" Ext	1-1/4" (32)	25.4 (11.5)	10	1/2"	1/2"	370-1475 (501-2000)	1920 (2603)
CP7782SP-6	155-17786	#5 Spl. 6" Ext.	1-1/4" (32)	25.4	10	1/2"	1/2"	370-1475 (501-2000)	1920 (2603)
CP7783	155-07783	1" Square	1- 1/4" (32)	18.5	10.1	1/2"	1/2"	413-1253 (560-1700)	1770 (2400)
CP7783-6	155-77836	1" Square	1- 1/4" (32)	20.9	10.1	1/2"	1/2"	413-1253 (560-1700)	1770 (2400)
CP797	155-07971	1" Square	1-1/4" (32)	27 (12.3)	12	1/2"	1/2"	150-900 (200-1225)	1400 (1898)
CP797-6	155-07976	1" Sq 6" Ext.	1-1/4" (32)	29.75 (13.5)	10	1/2"	1/2"	150-900 (200-1225)	1400 (1898)
CP797-SP6	155-79715	#5 Spl. 6" Ext.	1-1/4" (32)	29.75 (13.5)	10	1/2"	1/2"	150-900 (200-1225)	1400 (1898)
CP5000	155-50000	1" Square	1-1/4" (32)	30.5 (13.83)	11.88	1/2"	1/2"	370-1600 (502-2169)	2000 (2712)
CP897-6	155-08676	1" Square	1-1/4" (32)	19 (8.62)	6.5	1/2"	1/2"	150-800 (203-1085)	1300 (1763)

AIR TOOLS // IMPACT WRENCHES (CP)

→ 3/8" & 1/2" Impact Wrenches



Impact Wrenches (CP)

3/8" HEAVY DUTY AIR IMPACT WRENCH

- One hand push button forward/reverse power regulator
- Handle exhaust directs air away from the work area
- 360° air inlet swivel prevents hose kinks
- **APPLICATIONS:** general repair, transmission work, exhaust systems and body shops
- **ULTIMATE TORQUE:** 200 ft./lb.



152-00724

ASCOT NO.	MFG. NO.	DESCRIPTION
152-00724	CP724H	3/8" Heavy Duty Air Impact Wrench

3/8" SUPER DUTY ANGLE IMPACT WRENCH

- High Durability
- Compact
- Powerful
- Comfort
- Great Control
- Easy operation
- Single handed forward/reverse operation
- 3 positions in forward and 1 in reverse
- 185 ft./lb. (250 Nm) of maximum torque in reverse



152-07727



ASCOT NO.	MFG. NO.	DESCRIPTION
152-07727	CP7727	3/8" Super Duty Angle Impact Wrench

1/2" SUPER DUTY ANGLE IMPACT WRENCH

- High durability
- Compact
- Powerful
- Comfort
- Great control
- Easy operation
- Single handed forward/reverse operation
- 3 positions in forward and 1 in reverse
- 220 ft./lb. (300 Nm) of maximum torque in reverse



153-07737

ASCOT NO.	MFG. NO.	DESCRIPTION
153-07737	CP7737	1/2" Super Duty Angle Impact Wrench

3/8" HEAVY DUTY AIR IMPACT WRENCH

- The most powerful 3/8" of its class for general maintenance
- Maximize operator comfort with an extremely light and well balanced design
- **Most convenient and unique reverse technology in the market**
- **ULTIMATE TORQUE:** 415 ft./lb.



152-07729

ASCOT NO.	MFG. NO.	DESCRIPTION
152-07729	CP7729	3/8" Heavy Duty Air Impact Wrench

1/2" SUPER DUTY AIR IMPACT WRENCH

- Tackle the tough jobs with the power and speed of this true workhorse
- Patented clutch provides smooth operation and extreme durability
- One hand push button forward reverse power regulator
- 4 positive power settings in forward and ultimate power in reverse
- Compact design with comfortable contoured handle
- **ULTIMATE TORQUE:** 610 ft./lb.



153-17492

ASCOT NO.	MFG. NO.	DESCRIPTION
153-07492	CP749	1/2" Impact Wrench
153-17492	CP749-2	2" Extended Anvil

1/2" HEAVY DUTY AIR IMPACT WRENCH

- One hand push button forward/reverse power regulator
- 4 positive power setting
- Ultimate power in reverse
- Differential regulator allows the operator to match the required power to the job
- Patented oil bath Dyna-Pact clutch delivers smooth operation and extended durability
- Handle exhaust with 360° air inlet swivel to prevent kinks
- Power and economy for general repair, transmission work, exhaust systems and body shops
- **ULTIMATE TORQUE:** 425 ft./lb.



153-00734

ASCOT NO.	MFG. NO.	DESCRIPTION
153-00734	CP734H	1/2" Impact Wrench
153-01734	CP734HK	KIT INCLUDES: CP734H, (1) Set of 5 SAE Sockets: 1/2", 5/8", 3/4", 7/8", 15/16"

AIR TOOLS // IMPACT WRENCHES (CP)



➔ 1/2" Impact Wrenches

1/2" SUPER DUTY AIR IMPACT WRENCH-TIRE TOOL

- Patented spring hammer clutch for smooth operation and extended durability
- Low air consumption and high torque make this tool very efficient
- ULTIMATE TORQUE:** 665 ft./lb.
- Comfort and control with new ergonomic grip and trigger
- SUITED FOR ALL MAINTENANCE APPLICATIONS:** Light vehicle tire changing operations, light vehicle mechanical repair, MRO applications



153-07336

ASCOT NO.	MFG. NO.	DESCRIPTION
153-00736	CP7736	1/2" Super Duty Air Impact Wrench-Tire Tool
153-07336	CP7736-2	2" Extended Anvil

1/2" SUPER DUTY AIR IMPACT WRENCH-TIRE TOOL

- 960 ft./lb. of torque (1,300 Nm)
- Hard anodized end plates
- Hard chromium aluminum cylinder
- Twin hammer mechanism
- Lightweight due to the Composite motor housing
- COMPACT:** Only 6.6" long
- Curved handle with rubber material resistant to most chemicals used in workshops
- Full teasing trigger
- 360° swivel air inlet
- Friction ring socket retainer



153-07748

153-77482



The 1/2" Super Duty Air Impact Wrench-Tire Tool in use.

ASCOT NO.	MFG. NO.	DESCRIPTION
153-07748	CP7748	1/2" Super Duty Air Impact Wrench-Tire Tool
153-77482	CP7748-2	2" Extended Anvil

1/2" DRIVE STUBBY IMPACT WRENCH

- BEST POWER TO WEIGHT RATIO:** 450 ft./lb. (610 Nm)
- Ultra compact and easy to use
- Durable with a steel front cover and aluminum body
- One hand operation forward - reverse by either left or right-handed users
- 3 setting positions
- Jumbo hammer



153-07732



The 1/2" Drive Stubby Impact Wrench in use.

ASCOT NO.	MFG. NO.	DESCRIPTION
153-07732	CP7732	1/2" Drive Stubby Impact Wrench

1/2" HEAVY DUTY AIR IMPACT WRENCH

- Side-To-Side (S2S) forward/reverse functionality
- Perfectly balanced to reduce strain on wrist and forearm
- Twin hammer mechanism
- ULTIMATE TORQUE:** 955 ft./lb



153-77492



ASCOT NO.	MFG. NO.	DESCRIPTION
153-07749	CP7749	1/2" Impact Wrench
153-77492	CP7749-2	2" Extended Anvil

AIR TOOLS // IMPACT WRENCHES (CP)

➔ 3/4" & 1" Impact Wrenches



Impact Wrenches (CP) (cont.)

3/4" HEAVY DUTY AIR IMPACT WRENCH

- Smoothest operating 3/4" impact on the market
- One hand push button forward/reverse power regulator
- Handle exhaust with 360° air inlet swivel
- **APPLICATIONS:** spring work, truck and bus maintenance, farm machines & construction equipment
- **ULTIMATE TORQUE:** 1,000 ft./lb.



154-01772

ASCOT NO.	MFG. NO.	DESCRIPTION
154-00772	CP772H	3/4" Impact Wrench
154-01772	CP772H-6	6" Extended Anvil

3/4" HEAVY DUTY AIR IMPACT WRENCH

- Reduced Length at only 7.9"
- All controls within reach
- Variable speed trigger
- One-hand power adjustment
- One-hand reverse system
- 1440 ft./lb. (1950 Nm) of maximum torque
- Composite motor housing
- Twin hammer mechanism
- 360° swivel air inlet
- Socket retainer ring combined with hole retainer



154-77696

ASCOT NO.	MFG. NO.	DESCRIPTION
154-07769	CP7769	3/4" Impact Wrench
154-77696	CP7769-6	6" Extended Anvil

3/4" SUPER DUTY AIR IMPACT WRENCH - "D" HANDLE

- **LIGHTWEIGHT:** 3/4" at only 14.3 lb.
- 1300 ft./lb. (1760 Nm maximum torque in reverse)
- Twin hammer mechanism
- Steel motor
- Intuitive Forward/Reverse lever & power regulator on both sides
- 4-position power settings on both sides
- Side handle with soft-touch grip
- Down exhaust
- Aluminum housing
- Composite cover on the clutch housing
- Socket retainer ring



154-37763

ASCOT NO.	MFG. NO.	DESCRIPTION
154-27763	CP7763D	1" Short Shank
154-37763	CP7763D-6	6" Extended Anvil

1" HEAVY DUTY AIR IMPACT WRENCH

- **Chicago Pneumatic's strongest and most powerful 1" Impact Wrench**
- Operator productivity
- Convenient reverse valve
- Ideal for high volume tire work on trucks, buses, and heavy equipment
- 1" impact wrench with 7" extended anvil
- Rocking dog clutch
- 4-position power settings throttle for ease of use



155-50000

ASCOT NO.	MFG. NO.	DESCRIPTION
155-50000	CP5000	7" Extended Anvil

1" SUPER DUTY AIR IMPACT WRENCH

- 14.5 lb. (6.6 kg)
- Twin hammer mechanism
- Steel motor
- Intuitive forward/reverse lever & power regulator on both sides
- 4-position power settings on both sides
- Side handle with soft touch grip
- Down exhaust
- Aluminum housing
- Composite cover on the clutch housing
- Socket retainer ring
- 1300 ft./lb. (1760 Nm) maximum torque in reverse



155-77736

ASCOT NO.	MFG. NO.	DESCRIPTION
155-07773	CP7773D	1" Short Shank
155-77736	CP7773D-6	6" Extended Anvil

1" HEAVY DUTY AIR IMPACT WRENCH

- High performance clutch provides longer life under tough conditions
- High-efficiency 6 vane motor for maximum performance
- Bottom exhaust directs exhaust away from the operator
- Three-position power regulator with directional control
- **ULTIMATE TORQUE:** 1,620 ft./lb.

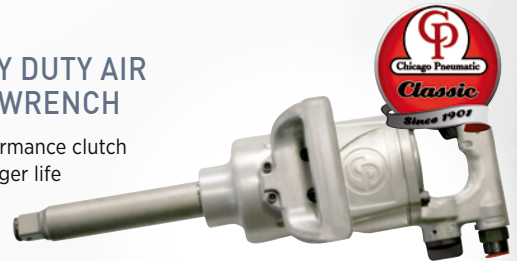

155-77786

ASCOT NO.	MFG. NO.	DESCRIPTION
155-07778	CP7778	1" Short Shank
155-77786	CP7778-6	6" Extended Anvil
155-27786	CP7778SP-6	#5 Spline with 6" Extended Anvil

AIR TOOLS // IMPACT WRENCHES (CP)





1" Heavy Duty Air Impact Wrench

- **2140 ft./lb. (2900 Nm) of maximum torque in reverse**
- Pinless closed reinforced rocking dog impact mechanism
- Socket retainer ring combined with hole retainer
- Ergonomic side handle
- Full teasing trigger
- Regulator with integrated forward/reverse with 3-position power settings in both directions



FULL TEASING TRIGGER

155-77826

ASCOT NO.	MFG. NO.	DESCRIPTION
155-07782	CP7782	1" Short Anvil
155-77826	CP7782-6	6" Extended Anvil
155-17782	CP7782-SP6	#5 Spline with 6" Extended Anvil

1" HEAVY DUTY AIR IMPACT WRENCH

- **High Operator Comfort-Ergonomic D-Handle with full teasing trigger**
- **HIGH DURABILITY:** Pinless closed reinforced rocking dog mechanism in oil bath
- **SHOCK ABSORBING:** Rubber bumper protecting both applications and tool (included)
- **POWERFUL AND LIGHT:** 1770 ft./lb. (2400 Nm) in reverse

D-HANDLE FOR COMFORT

RUBBER BUMPER



155-07783



155-77836

ASCOT NO.	MFG. NO.	DESCRIPTION
155-07783	CP7783	1" Short Shank
155-77836	CP7783-6	6" Extended Anvil

1" HEAVY DUTY AIR IMPACT WRENCH

- **LIGHTWEIGHT:** Only 6.9 lb. (3.15 kg) thanks to a composite motor housing for an improved operator comfort
- Socket retainer ring combined with hole retainer
- Twin hammer mechanism
- **ALL CONTROLS WITHIN REACH:** Variable speed trigger, One-hand power adjustment, One-hand reverse system
- 360° swivel air inlet
- 1440 ft./lb. (1950 Nm in reverse)



155-07779

ASCOT NO.	MFG. NO.	DESCRIPTION
155-07779	CP7779	1" Impact Wrench
155-17779	CP7779-6	6" Extended Anvil

1" SUPER DUTY AIR IMPACT WRENCH

- Rocking dog clutch for smooth operation and extreme durability
- Teasing throttle for easy bolt starting
- Convenient reverse valve for easy directional changes
- Choice of professional mechanics for high volume tire work on trucks, buses and heavy equipment
- **ULTIMATE TORQUE:** 1,400 ft./lb.



155-07976

ASCOT NO.	MFG. NO.	DESCRIPTION
155-07971	CP797	1" Short Shank
155-07976	CP797-6	6" Extended Shank
156-79716	CP797SP-6	6" Extended Shank and #5 Spline

AIR TOOLS // IMPACT WRENCHES (CP)

Sanders & Blue Tork

HEAVY DUTY HIGH-SPEED SANDER

- Built-in regulator and variable speed throttle for precise speed control
- Rugged, energy efficient 1/2 HP motor
- **APPLICATIONS:** Ideal for small jobs or hard to reach spots including paint removal, shaping filler patches, smoothing and rust removal
- **FREE SPEED:** 14,000 RPM



158-00778

ASCOT NO.	MFG. NO.	DESCRIPTION
158-00778	CP9778	Heavy Duty High-Speed Sander

MINI DISC SANDER KIT

- **KIT INCLUDES:** CP7202 Mini Disc Sander plus (1) 3" backing pad, (10) 3" 80, 100 & 120 grit sanding discs, (1) 3" fine, medium and coarse surface prep disc & a spindle wrench packed in a heavy duty carrying case
- **FREE SPEED:** 15,000 RPM



158-07202

ASCOT NO.	MFG. NO.	DESCRIPTION
158-07202	CP7202D	Mini Disc Sander Kit

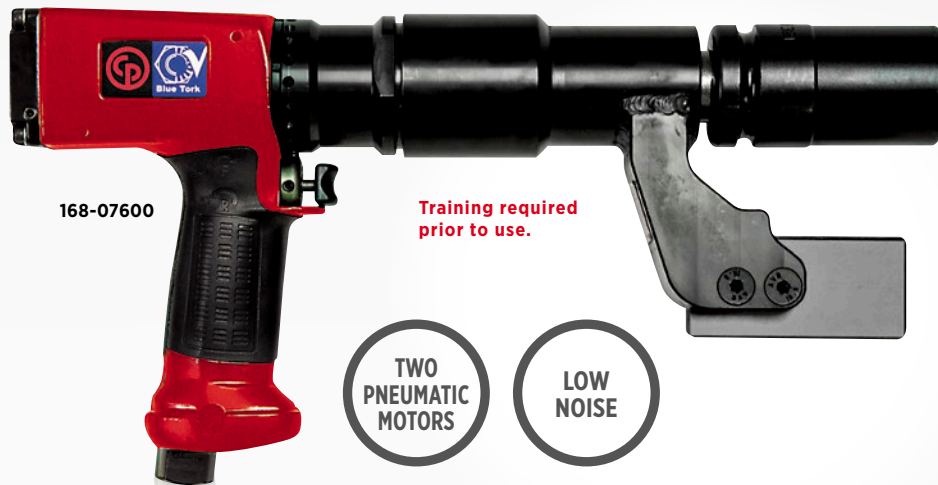

168-07600

Training required prior to use.

TWO PNEUMATIC MOTORS

LOW NOISE

1" Non-Impact Wrench (Blue Tork)

- Two pneumatic motors for rundown and final tightening
- Preset and adjustable shut off for torque control
- **QUALITY:** Precise, accurate tightening to the manufacturer's recommended torque and angle specifications
- **ENVIRONMENT IMPROVEMENTS:** by increasing durability of the tools, we reduce waste
- **ERGONOMICS:** very low noise level, virtually no vibration
- **EFFICIENCY:** Precise and accurate tightening, less fatigued operators
- **MAXIMUM TORQUE:** 660 ft./lb.

ASCOT NO.	MFG. NO.	DESCRIPTION
168-07600	CP7600xB	Non-Reversible Single Torque Preset
168-07602	CP7600xB-R	Reversible Single Torque Preset
168-07603	CP7600xB-R4P	Reversible 4 Torque Preset Selector



Air Ratchets

QUICK REFERENCE CHART

CP No.	Ascot No.	Sq. Drive (mm)	Std Bolt Size (mm)	Net Weight (kg.)	Average Air Cons. (CFM)	Air Inlet (NPTF) In.	Min. Hose Size (inch)	Working Torque Range (ft./lb.)	Max. Torque (ft./lb.)
CP826	151-00826	1/4" (6)	1/4" (6)	1.13 (0.51)	3.5	1/4"	3/8" (10)	5-15 (7-20)	15 (20)
CP828	152-00828	3/8" (10)	3/8" (10)	2-5/8 (1.2)	4	1/4"	3/8" (10)	10-50 (14-68)	50 (68) 150 RPM
CP7829	152-07829	3/8" (10)	3/8" (10)	1.235 (2.72)	4	1/4"	3/8" (10)	10-55 (15-68)	95 (70)
CP7830Q	152-07830	3/8" (10)	3/8" (10)	2.7 (1.2)	5 (142)	1/4"	3/8" (10)	10-90 (14-136)	90 (122)

1/4" SUPER DUTY AIR RATCHET

- Exceptional durability with an advanced head design that virtually eliminates slippage
- Urethane grip for comfort and control
- Faster rundown with 250 RPM
- **APPLICATIONS:** Under-dashboard work, small engine repair and body shops
- **ULTIMATE TORQUE:** 15 ft./lb.



151-00826

ASCOT NO.	MFG. NO.	DESCRIPTION
151-00826	CP826	1/4" Super Duty Air Ratchet

3/8" HEAVY DUTY AIR RATCHET

- Advanced motor, full caged gear, and head design
- Only 10.7in / 272mm long
- Better access to restricted areas
- 2.7 lb. / 1.2 kg
- Adjustable side exhaust avoids blowing dirt and dust
- Ergonomic composite grip insulates operator's hand from cold
- Designed for a variety of applications from heavy ones such as transmission and suspension work to light ones such as engine repair, dashboard work and general maintenance
- **ULTIMATE TORQUE:** 70 ft./lb.



152-07829

ASCOT NO.	MFG. NO.	DESCRIPTION
152-07829	CP7829	3/8" Heavy Duty Air Ratchet
153-07829	CP7829H	1/2" Heavy Duty Air Ratchet

3/8" EXTREME DUTY AIR RATCHET

- Adjustable side exhaust
- **LOW NOISE LEVEL:** Only 79 dBA
- One of the highest torques available on the market
- CP's Patented TriSpring anti-slip head design



ASCOT NO.	MFG. NO.	DESCRIPTION	152-07830
152-07830	CP7830Q	3/8" Super Duty Ratchet	
153-07830	CP7830HQ	1/2" Super Duty Ratchet	

3/8" QUIET AIR RATCHET

- **APPLICATIONS:** exhaust systems, small engines, water and fuel pumps and radiator and air conditioner removal and replacement
- New advanced, patented head design
- Patented ergonomic square-handle design for a comfortable grip
- Efficient 1/2 HP motor and triple idler planetary gear system
- **ULTIMATE TORQUE:** 50 ft./lb.



ASCOT NO.	MFG. NO.	DESCRIPTION	152-00828
152-00828	CP828	3/8" Quiet Air Ratchet	
153-08281	CP828H	1/2" Quiet Air Ratchet	



The 3/8" Air Ratchet in use.

AIR TOOLS // SANDERS & AIR RATCHETS (CP)

➔ Needle Scaler, Cut-Off Tools, Tire Buffers

Needle Scaler, Cutter, Tire Buffers (CP)

NEEDLE SCALER

- Ideal for surface preparation work
- Adjustable sleeve allows needle clearance based on the application
- 19 1/8" steel needles with high resistance to wear
- Easily converts to a weld flux chipping hammer
- **BLOWS PER MINUTE:** 4,800



157-07120

ASCOT NO.	MFG. NO.	DESCRIPTION
157-07120	CP7120	Needle Scaler

HIGH SPEED CUTTER

- Adjustable speed regulator for precise control
- Lock off throttle to prevent accidental start up
- Rear exhaust directs air away from work area
- **MAX RPM:** 22,000



157-00874



ASCOT NO.	MFG. NO.	DESCRIPTION
157-00874	CP874	High Speed Cutter
173-00101	CW1	Cut-Off Wheel
173-00220	CW20	Arbor for High Speed Cutter (Fits 3" & 4" Cut-Off Wheels)

LOW SPEED TIRE BUFFER KIT

- Quick change slip chuck for fast and easy change of buffing wheel
- Adjustable speed regulator for precise control
- Lock off throttle to prevent accidental start ups
- Rear exhaust directs air away from work area
- **FREE SPEED:** 2,800 RPM



158-00873

ASCOT NO.	MFG. NO.	DESCRIPTION
158-00873	CP873K	Includes Over Hose
158-01873	CP873	Low Speed Tire Buffer Only

HIGH SPEED TIRE BUFFER KIT

- Jacobs chuck for holding buffing accessories
- Lock-off throttle
- **APPLICATIONS:** tire patchwork, roughing areas for recapping and cleaning tire moldings
- **FREE SPEED:** 22,000 RPM



158-00871

ASCOT NO.	MFG. NO.	DESCRIPTION
158-00871	CP871K	Includes Over Hose
158-01871	CP871	High Speed Tire Buffer Only

Grinders & Surface Conditioning Discs

2" QUICK CHANGE SURFACE CONDITIONING DISCS

- Embedded with abrasive grain to eliminate fraying of edges, resist loading and provide a consistent finish
- Ideal for flat or contoured surfaces
- **APPLICATIONS:** Light deburring, surface preparation, blending scratches, removing rust, corrosion and oxidation, removing stains from stainless steel, finishing aluminum and stainless steel
- Available in fine, medium or coarse



ASCOT NO.	MFG. NO.	DESCRIPTION
417-39120	3912BLUEF	2" Quick Change Surface Conditioning Discs: Blue (Fine)
417-39121	3912MARNM	2" Quick Change Surface Conditioning Discs: Maroon (Medium)
417-39122	3912BRWNC	2" Quick Change Surface Conditioning Discs: Brown (Coarse)
417-39202	392002	Backing Pad for 2" Surface Conditioning Discs



417-39120

417-39121

417-39122

417-39202



➔ Surface Conditioning Discs, Bristle Discs, Grinders, Grinder Kits

Grinders & Surface Conditioning Discs (cont.)

2" SURFACE CONDITIONING DISCS

- **Best used on aluminum parts**
- **USA MADE** ▪ **QUANTITY:** 25 per box
- **MAXIMUM OPERATING SPEED:** 25,000



417-13004

417-13003,
417-13005



ASCOT NO.	MFG. NO.	DESCRIPTION	QTY./BOX
417-13003	620TE-1	2" Surface Conditioning Discs: Brown (Coarse)	25
417-13004	622TE-1	2" Surface Conditioning Discs: Maroon (Medium)	25
417-13005	620TE-1-50	2" Surface Conditioning Discs: Brown (Coarse)	50

MINI ANGLE DIE GRINDER

- Compact, lightweight design for easy maneuverability ▪ 90° angle head allows flexibility in confined areas
- Complete with 1/4" and 6mm collet
- **APPLICATIONS:** high speed blending, smoothing, porting, and deburring in confined areas ▪ **MAX RPM:** 22,500



157-00875

ASCOT NO.	MFG. NO.	DESCRIPTION
157-00875	CP875	Mini Angle Die Grinder

MINI DIE GRINDER

- Compact, lightweight design for easy maneuverability ▪ Adjustable speed regulator for precise control
- Complete with 1/4" and 6mm collet ▪ **APPLICATIONS:** high speed blending, smoothing, porting, and deburring in confined areas ▪ **MAX RPM:** 30,000



157-00876

ASCOT NO.	MFG. NO.	DESCRIPTION
157-00876	CP876	Mini Die Grinder

STRIP-BRITE PADS

- **Used for paint or coating removal**
- Features the quick and easy twist-to-lock attachment system
- Open-web construction impregnated with silicon carbide to provide aggressive and long-lasting performance
- Three-dimensional web has a soft edge, allowing it to remove paint and other coatings in those unreachable creases and dents while removing very little metal
- Ideal for stripping paint without damaging metal, especially on aluminum
- **QUANTITY:** 10 per Box

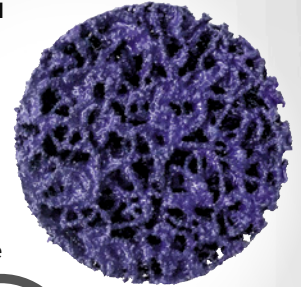

417-16210



ASCOT NO.	MFG. NO.	DESCRIPTION
417-16210	16210	Purple 2" Strip-Brite Pad
417-16211	16211	Purple 3" Strip-Brite Pad

2" ANGLE GRINDER KIT

- **KIT INCLUDES:** Pin Wrench, Spanner, (3) each 2" 60, 80 & 120 Grit Grinding Wheels, (5) each 2" Cutting Wheels and Protective Glasses packed in a heavy duty carrying case ▪ **FREE SPEED:** 22,000 RPM



157-07500

ASCOT NO.	MFG. NO.	DESCRIPTION
157-07500	CP7500DK	2" Angle Grinder Kit

MINI ANGLE DIE GRINDER KIT

- **KIT INCLUDES:** (1) 2" backing pad, (2) 2" coarse surface prep pads, (2) 2" medium surface prep pads, (2) 2" fine surface prep pads, (2) 2" 50 grit sanding discs, (2) 2" 36 grit sanding discs, (2) 2" 24 grit sanding discs paced in a heavy duty carrying case ▪ **MAX RPM:** 22,500



157-01875

ASCOT NO.	MFG. NO.	DESCRIPTION
157-01875	CP875K	Mini Angle Die Grinder Kit

AIR TOOLS // BUFFERS, GRINDERS, DRILLS & ACCESSORIES

Drills (CP)

AIR TOOLS // BUFFERS, GRINDERS, DRILLS & ACCESSORIES

1/4" REVERSIBLE MINI AIR DRILL



- Composite housing with thermoplastic rubber handle grip
- Wings on right & left sides to guide the forefinger
- Large teasing trigger and progressive valve allowing more control to start holes
- Low speed gear box
- Flat back part for better pushing action while drilling and tapping
- Reverse lever on the top for easier access
- Handle exhaust allowing the air to flow away from the operator
- Supplied with high quality industrial Jacobs® chucks for longer use
- keyed Metal
- APPLICATIONS:** Excellent for drilling, honing, reaming and hole sawing
- FREE SPEED:** 3,300 RPM



157-07302

ASCOT NO.	MFG. NO.	DESCRIPTION
157-07302	CP7300RC	1/4" Reversible Mini Air Drill

1/4" MINI AIR DRILL

- Composite housing with thermoplastic rubber handle grip
- Wings on right & left sides to guide the forefinger
- Large teasing trigger and progressive valve allowing more control to start holes
- Low speed gear box
- Flat back part for better pushing action while drilling and tapping
- Handle exhaust allowing the air to flow away from the operator
- Supplied with high quality industrial Jacobs® chucks for longer use
- keyed Metal
- APPLICATIONS:** Excellent for drilling, honing, reaming and hole sawing
- FREE SPEED:** 3,300 RPM



157-17302

ASCOT NO.	MFG. NO.	DESCRIPTION
157-17302	CP7300C	1/4" Mini Air Drill

3/8" REVERSIBLE DRILL



- Teasing throttle for precise control
- APPLICATIONS:** Screwdriving, honing and heavy drilling
- FREE SPEED:** 2,600 RPM



157-78926

ASCOT NO.	MFG. NO.	DESCRIPTION
157-78926	CP789-R26	3/8" Reversible Drill

3/8" REVERSIBLE ANGLE DRILL



- Composite housing with thermoplastic rubber handle grip
- Lock-off throttle for more controlled applications
- Built-in Forward-Reverse ring
- Compact low profile head to get into confined spaces
- Handle exhaust allowing the air to flow away from the operator
- Supplied with high quality industrial Jacobs® chucks for longer use
- APPLICATIONS:** Excellent for drilling and screw driving in confined areas
- FREE SPEED:** 2,000 RPM



157-01879

ASCOT NO.	MFG. NO.	DESCRIPTION
157-01879	CP879C	3/8" Reversible Drill

1/2" REVERSIBLE DRILL

- Teasing throttle for precise control
- APPLICATIONS:** heavy drilling, reaming, hole sawing and jobs requiring a lot of torque
- FREE SPEED:** 500 RPM



157-00789

ASCOT NO.	MFG. NO.	DESCRIPTION
157-00789	CP789-HR	1/2" Reversible Drill



Air Tool Accessories (CP)

PROTECTO-LUBE AIR TOOL OIL

ASCOT NO.	MFG. NO.	DESCRIPTION
181-00046	CA-000046	20 Oz.
181-14966	CA-149661	4 Oz.

PVC CUSHION-COAT PROTECTIVE COVERS

TOOL NO.	ASCOT NO.	MFG. NO.
CP734H	177-12940	CA-129405
CP749, CP749-2	177-15553	CA-155537
CP772H	177-12474	CA-124745
CP7733-2	177-77332	8940158949
CP7778, CP7778-6	177-17778	8940163099

REPAIR KITS

TOOL NO.	ASCOT NO.	MFG. NO.
CP724H	176-55310	CA-155310
CP749	176-58636	8940158636
CP7749/7749-2	176-88482	8940167482
CP7733	176-88861	8940158861

TUNE-UP KITS

TOOL NO.	ASCOT NO.	MFG. NO.
CP721	176-18880	CA-188880
CP724H	176-55218	CA-155218
CP749	176-14861	8940158635
CP749-2	176-14866	8940158635
CP7733/7733-2	176-89860	8940158860
CP796	176-26992	CA-126992
CP7778/7778-6	176-89816	8940162816
CP7775/7775-6/7775SP-6	176-62206	8940162206
CP7782-6	176-89447	8940169847

IMPACT WRENCH ACCESSORIES

ASCOT NO.	MFG. NO.	DESCRIPTION
175-82651	H-082651	1" Impact Wrench Retainer Clip O-Ring
175-83071	P-08371	O-Ring for 1/2" Impact Wrench Retainer Clips
175-88097	CA-088097	1/2" CP Impact Wrench Retainer Clips
175-94791	CA-094791	1" Impact Wrench Retainer Clip

HAMMER ACCESSORIES

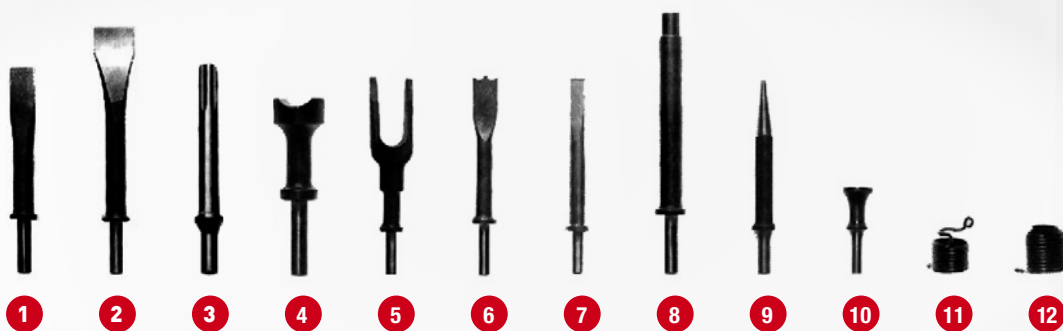

INDEX NO.	ASCOT NO.	MFG. NO.	DESCRIPTION
1	171-47050	A-047050	Rivet Cutter
2	171-47051	A-047051	Wide Cutting Chisel
3	171-47052	A-047052	Bushing Splitter
4	171-47057	A-047057	U-Joint & Tie Rod Tool
5	171-47059	A-047059	1" Separator Fork
	171-47061	A-047061	1-1/4" Separator Fork
6	171-47071	A-047071	Twin Blade Cutter
7	171-47073	A-047073	Cold Chisel

INDEX NO.	ASCOT NO.	MFG. NO.	DESCRIPTION
8	171-47074	A-047074	Straight Punch
9	171-47078	A-047078	Tapered Punch
10	171-47091	A-047091	1-1/4" Smoothing Hammer
11	171-47095	A-047095	Quick-Change Retainer
12	171-47096	A-047096	Bee-Hive Retainer
	171-47270	CA-047270	2' Leader Hose
	171-47300	CA-047300	Quick Change Coupler
	171-47032	CA-047302	Nipple

AIR TOOLS // BUFFERS, GRINDERS, DRILLS & ACCESSORIES



WARNING: For more information go to www.P65Warnings.ca.gov.

ASCOT SUPPLY CORPORATION

BUYER'S GUIDE



RPG AIR TOOLS

155-17786

156-17786

155-26464

155-12856

156-12856

RPG 1" DRIVE & #5 SPLINE SUPER DUTY AIR IMPACT WRENCH

- 6" extended anvil ▪ Steel end plates ▪ **WORKING TORQUE RANGE:** 1,600-1,800 ft./lb.
- **FREE SPEED:** 4,500 RPM
- **MAXIMUM TORQUE:** 1,800 ft./lb.
- Replacement parts available

RPG 1" DRIVE MINI PLUS AIR IMPACT WRENCH

- 6" extended anvil ▪ 3-position power setting ▪ Rubber-coated side handle for added comfort ▪ Powered by the twin hammer clutch ▪ **FREE SPEED:** 5,000 RPM ▪ **MAXIMUM TORQUE:** 2,000 ft./lb.

RPG 1" & #5 SPLINE DRIVE SUPER DUTY AIR IMPACT WRENCH

- 6" extended anvil ▪ 3-position forward and reverse ▪ High efficiency 6-vane motor
- Swoop-back side handle for maneuverability and balance
- Pinless clutch mechanism
- **WORKING TORQUE RANGE:** 1,800-2,000 ft./lb. ▪ **FREE SPEED:** 5,000 RPM ▪ **MAXIMUM TORQUE:** 2,000 ft./lb.

REPLACEMENT PARTS



ASCOT NO.	MFG. NO.	DESCRIPTION
REPLACEMENT PARTS FOR A778-6 1" DRIVE IMPACT WRENCH		
175-10026	#26	Set of 6 Rotor Blades for A778-6 1" Drive Impact Wrench
175-10037	#37	Hammer for A778-6 1" Drive Impact Wrench
175-10040	#40	Hammer Cage for A778-6 1" Drive Impact Wrench
175-10043	#43	Replacement Side Handle Kit for A778-6 1" Drive Impact Wrench
176-18406	A778-6TK	Tune-Up Kit for A778-6 1" Drive Impact Wrench

IMPACT WRENCH SPECIFICATIONS

ASCOT NO.	MFG. NO.	SQUARE DRIVE	FREE SPEED (RPM)	MAX TORQUE (FT./LB.)	AIR PRESSURE (PSI)	AIR CON. AVG (CFM)	AIR INLET (NPT)	HOSE SIZE	LENGTH	WEIGHT (LB.)
155-12856	A2856	1"	5,000	2,000	—	12	1/2"	3/4"	20.5"	27.6
155-17786	A778-6	1"	4,500	1,800	90	8.4	1/2"	3/4"	20.3"	26.59
155-26464	A26464	1"	5,000	1,800	90	9	1/2"	3/4"	19.2"	17.86
156-12856	A2856SP	#5 Spline	5,000	2,000	—	12	1/2"	3/4"	20.5"	27.6
156-17786	A778SP-6	#5 Spline	4,500	1,800	90	8.4	1/2"	3/4"	20.3"	26.59

AIR TOOLS // RPG AIR TOOLS



153-23120



153-23121



153-12131

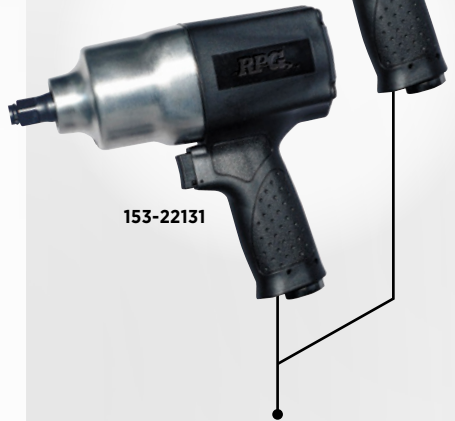

153-22131



153-33120



153-33121



RPG 1/2" DRIVE SUPER DUTY AIR IMPACT WRENCH

- 2" extended anvil ▪ FREE SPEED: 8000 RPM ▪ MAXIMUM TORQUE: 600 ft./lb. ▪ Proven design and the most popular configuration in the tire service industry ▪ Powered by the durable and high performing twin hammer mechanism ▪ Handle exhaust

RPG 1/2" DRIVE SUPER DUTY COMPOSITE IMPACT WRENCH

- 2" extended anvil ▪ FREE SPEED: 8,000 RPM ▪ MAXIMUM TORQUE: 700 ft./lb. ▪ Composite body offering lighter weight and improved balance ▪ Swivel air inlet for ease of use ▪ Powered by the durable and high performing twin hammer mechanism ▪ Handle exhaust

RPG 1" DRIVE SUPER DUTY AIR IMPACT WRENCH W/ RUBBER GRIP

- 2" extended anvil ▪ FREE SPEED: 8,000 RPM ▪ MAXIMUM TORQUE: 600 ft./lb. ▪ Powered by the durable and high performing twin hammer mechanism ▪ Proven design and the most popular configuration in the tire service industry ▪ Handle exhaust ▪ Rubber grip

See A2312 Impact Wrench Replacement Parts & Accessories on the next page

AIR TOOLS // RPG AIR TOOLS

IMPACT WRENCH SPECIFICATIONS

ASCOT NO.	MFG. NO.	SQUARE DRIVE	FREE SPEED (RPM)	MAX TORQUE (FT./LB.)	AIR PRESSURE (PSI)	AIR CON. AVG (CFM)	AIR INLET (NPT)	HOSE SIZE	LENGTH	WEIGHT (LB.)
153-12131	A2131-COMP	1/2"	8,000	700	90	4	1/4"	3/8"	9.6"	5.01
153-22131	SS-A2131-COMP	1/2"	8,000	700	90	4	1/4"	3/8"	7.6"	4.74
153-23120	A2312	1/2"	8,000	600	90	4	1/4"	3/8"	8-1/8"	5.6
153-23121	SS-A2312	1/2"	8,000	600	90	4	1/4"	3/8"	6.1"	5.95
153-33120	A2312G	1/2"	8,000	600	90	4	1/4"	3/8"	8-1/8"	5.6
153-33121	SS-A2312G	1/2"	8,000	600	90	4	1/4"	3/8"	6.1"	5.95



RPG AIR TOOLS (cont.)

REPLACEMENT PARTS FOR A2312 1/2" DRIVE IMPACT WRENCH



175-10029



175-13457

ASCOT NO. MFG. NO. DESCRIPTION

REPLACEMENT PARTS FOR A2312 1/2" DRIVE IMPACT WRENCH

175-10029	A2312-RB	Set of 6 Rotor Blades for A2312 Impact Wrench
175-13457	A2312-HTK	Hammer Tune-Up Kit for A2312 Impact Wrench

Replacement Parts are for the A2312 Impact Wrench on the previous page

IMPACT WRENCH ACCESSORIES



175-23104

ASCOT NO. MFG. NO. DESCRIPTION

175-23104	JB-04Blue	Blue Protective Boot for RPG A2312 Impact Wrenches
175-82651	H-082651	1" Impact Wrench Retainer Clip O-Ring
175-83071	P-08371	O-Ring for 1/2" Impact Wrench Retainer Clips



1,100 FT./LBS. MAX. TORQUE

6-Position power setting

MOST POWERFUL 3/4" DRIVE

DURABLE & HEAVY DUTY

RPG 3/4" DRIVE IMPACT WRENCH

- Short anvil
- 6-position power setting
- **FREE SPEED:** 5,500 RPM
- **MAXIMUM TORQUE:** 1,100 ft./lb.
- The most powerful 3/4" drive classic wrench
- Suitable for tire or engine work on truck, bus or farm machinery
- Handle exhaust

IMPACT WRENCH SPECIFICATIONS

ASCOT NO.	MFG. NO.	SQUARE DRIVE	FREE SPEED (RPM)	MAX TORQUE (FT./LB.)	AIR PRESSURE (PSI)	AIR CON. AVG (CFM)	AIR INLET (NPT)	HOSE SIZE	LENGTH	WEIGHT (LB.)
154-10261	A261	3/4"	5,500	1,100	-	9.5	3/8"	1/2"	8.2"	12.9

AIR TOOLS // RPG AIR TOOLS



RPG LOW SPEED TIRE BUFFER WITH QUICK CHANGE SLIP CHUCK

- Brass bushings provide performance and durability in tough working conditions
- Includes whip hose and exhaust hose
- Quick change slip chuck for fast and easy change of buffing wheel
- Built-in regulator
- Lock off throttle to prevent accidental start ups
- Rear exhaust directs air away from the work area
- Ideal for patchwork, roughing areas for recapping and cleaning tire moldings
- *Overhose Kit also Available Separately (175-00873)*

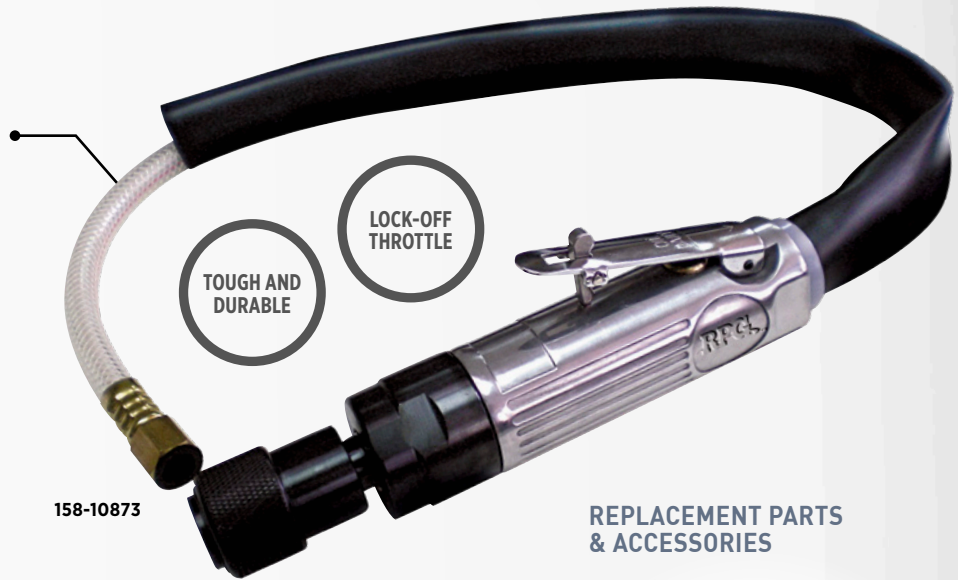

158-10873

REPLACEMENT PARTS & ACCESSORIES



175-00873 175-18713 175-28713

RPG HIGH SPEED TIRE BUFFER WITH OVERHOSE KIT

- Jacobs chuck for holding buffing accessories
- Lock-off throttle
- **FREE SPEED:** 22,000 RPM
- **APPLICATIONS:** Tire patchwork, roughing areas for recapping and cleaning tire moldings
- Includes overhose kit



158-10871

RPG HIGH SPEED BUFFER KIT WITH QUICK CHANGE CHUCK

- Quick change chuck for holding buffing accessories
- Lock-off throttle
- **FREE SPEED:** 22,000 RPM
- **APPLICATIONS:** Tire patchwork, roughing areas for recapping and cleaning tire moldings
- Includes overhose kit



158-11871

ASCOT NO.	MFG. NO.	DESCRIPTION
REPLACEMENT PARTS FOR AIR BUFFERS		
175-00873	A-873K-OH	Overhose Kit for Tire Buffers
175-18713	A8713-TA	Trigger Assembly for Tire Buffers
175-28713	SQC01	Replacement 7/16" Quick Change Slip Chuck
ACCESSORIES FOR AIR BUFFERS		
173-00018	QC18	Quick Chuck Adapter W/ Collar
173-00019	QC19	Quick Chuck Adapter W/ Spacer, 1" x 3/8" Thread
173-00020	QC20	Quick Chuck Adapter For 1/8" Shank
173-00022	QC22	Quick Chuck Adapter For 1/4" Shank
173-00023	QC23	Quick Chuck Adapter For 5/16" Shank

TIRE BUFFER SPECIFICATIONS

ASCOT NO.	MFG. NO.	DESCRIPTION	FREE SPEED (RPM)	LENGTH
158-10873	A873K	Low Speed Tire Buffer with Quick Change Chuck	2,800	1.75"
158-10871	A871K	High Speed Tire Buffer with Overhose kit	22,000	2.5"
158-11871	A871K-QC	High Speed Buffer Kit with Quick Change Chuck	22,000	1.75"

AIR TOOLS // RPG AIR TOOLS



RPG AIR TOOLS (cont.)

RPG 1/2" REVERSIBLE AIR DRILL



- Quick change chuck retainer
- Exhaust hose ▪ Side handle
- **FREE SPEED:** 500 RPM
- **CHUCK SIZE:** 1/2" ▪ Swivel air inlet for ease of use



157-01035

PARTS & ACCESSORIES

ASCOT NO. MFG. NO. DESCRIPTION

REPLACEMENT PARTS FOR 1/2" REVERSIBLE AIR DRILL		
175-01035	253340	Side Handle Kit for A1035 Air Drill
175-11035	H025	Air Hose Exhaust Kit for A1035 Air Drill



175-11035

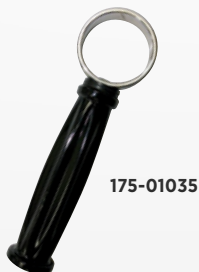

175-01035

RPG 3/8" HEAVY DUTY AIR DRILL

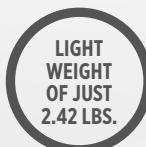

- Superior performance with a powerful 1/2 HP motor ▪ Light weight of just 2.42 lb. makes it easy to use ▪ Includes durable, heavy duty, industrial-style keyed chuck ▪ **CHUCK SIZE:** 3/8" ▪ **FREE SPEED:** 2,200 RPM

157-01038

RPG 1/4" AIR SCREWDRIVER



- Forward and reverse control on top ▪ Ergonomic handle design ▪ Variable speed trigger ▪ Built-in comfort grip ▪ Rotating air inlet ▪ Handle exhaust
- **NET WEIGHT:** 4.6 lb.
- **FREE SPEED:** 1,800 RPM

157-88725

AIR TOOL SPECIFICATIONS

ASCOT NO.	MFG. NO.	FREE SPEED (RPM)	AIR PRESSURE (PSI)	AIR CON. AVG (CFM)	AIR INLET (NPT)	HOSE SIZE	LENGTH	WEIGHT (LB.)
157-01035	A1035	500	90	4	1/4"	3/8"	7.5"	2.86
157-01038	A1038	2,200	90	6	1/4"	3/8"	8"	2.42
157-88725	A88-7251	1,800	90	4	1/4"	3/8"	7.7"	4.6

➔ Cut-Off Tool, Die Grinder, Adhesive Removal Tool

RPG WHEEL WEIGHT ADHESIVE REMOVAL TOOL

- High torque motor to cut through stubborn wheel weight adhesive, body pinstripes, etc.
- High RPM to prevent pad from bogging down
- Pad made of a tough and long-lasting material
- Rubber-insulated motor housing for hand comfort
- Lock-off trigger for added safety ▪ Includes eraser pad ▪ **SPINDLE THREAD:** 5/16"-24



157-03252

PARTS & ACCESSORIES

ASCOT NO. MFG. NO. DESCRIPTION

REPLACEMENT PARTS FOR WHEEL WEIGHT ADHESIVE TOOL

157-03253	A143252-6	Replacement Eraser Pads for Wheel Weight Adhesive Removal Tool (6 per Package)
-----------	-----------	--



157-03253

RPG 3" CUT-OFF TOOL

- Adjustable speed regulator for precise control ▪ Lock-off throttle to prevent accidental start-up ▪ Rear exhaust directs air away from work area ▪ Durable gears for top performance and long life ▪ **FREE SPEED:** 22,000 RPM

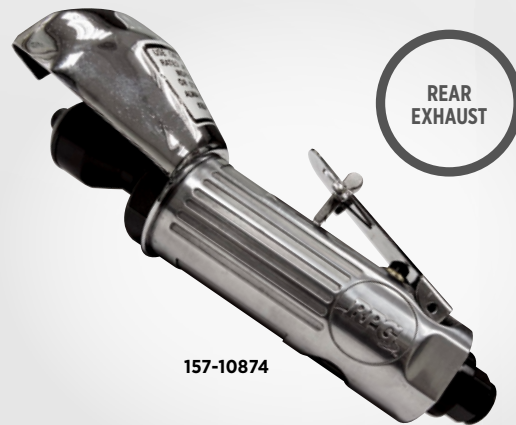

157-10874

RPG 1/4" MINI ANGLE DIE GRINDER

- Compact, lightweight design for easy use
- **APPLICATIONS:** High speed blending, smoothing, porting and deburring in confined areas ▪ Right angle for easy maneuvering ▪ **FREE SPEED:** 22,000 RPM



157-10875

AIR TOOL SPECIFICATIONS

ASCOT NO.	MFG. NO.	FREE SPEED (RPM)	AIR PRESSURE (PSI)	AIR CON. AVG (CFM)	AIR INLET (NPT)	HOSE SIZE	LENGTH	WEIGHT (LB.)
157-03252	A143252	3,700	90	4	1/4"	3/8"	7.9"	1.8
157-10874	A874	22,000	90	5	1/4"	3/8"	7.25"	1.75
157-10875	A875	22,000	90	5	1/4"	3/8"	5"	1



Milwaukee Power Tools

CORDLESS 1/2" DRIVE IMPACT WRENCH

▪ **4 CUSTOMIZABLE MODES:** Provides multiple fastening torque outputs designed for sedans, light trucks and box trucks ▪ **POWERSTATE™ BRUSHLESS MOTOR:** Delivers up to 750 ft./lb. of fastening torque and 1,100 ft./lb. of nut-busting torque ▪ **LONG MOTOR LIFE:** POWERSTATE™ Brushless Motor delivers maximum power and long motor life ▪ **FASTER TIRE SERVICE:** Enables users to perform faster tire service by removing the hassle of pneumatic hoses, compressors, and torque sticks ▪ **PART OF THE M18™ SYSTEM:** Featuring over 175+ Tools

CORDLESS 1" DRIVE IMPACT WRENCH

▪ **POWERSTATE™ BRUSHLESS MOTOR:** Delivers up to 1,800 ft./lb. nut-busting torque, making it the world's most powerful cordless impact wrench ▪ Up to 7 lb. lighter weight allowing for less user fatigue ▪ **ONE-KEY™ COMPATIBLE:** Ability to customize, track and manage tools for increased productivity and investment protection ▪ **4-MODE DRIVE CONTROL™:** Provides greater control over output speed and power ▪ **LOWER OWNERSHIP COST:** Eliminates compressors and generators, providing greater portability and lower cost of ownership ▪ Includes the ability to set a repeatable torque output for maximum control

AIR TOOLS // MILWAUKEE AIR TOOLS



153-76920

LONG MOTOR LIFE

PART OF THE M18™ SYSTEM

LONG MOTOR LIFE



155-86720

PART OF THE M18™ SYSTEM



153-76922



155-86722

ASCOT NO.	MFG. NO.	DESCRIPTION
153-76920	2769-20	Cordless 1/2" Drive Impact Wrench - 2" Extended Anvil (Bare Tool)
153-76922	2769-22	Cordless 1/2" Drive Impact Wrench - 2" Extended Anvil (Kit)

ASCOT NO.	MFG. NO.	DESCRIPTION
155-86720	2867-20	Cordless 1" Drive Impact - Standard Anvil (Bare Tool)
155-86722	2867-22	Cordless 1" Drive Impact - Standard Anvil (Kit)





➔ Cordless Tool Kit, Cordless 1/2" Stubby Impact Wrench Kit

2-PIECE CORDLESS TOOL KIT: 1/2" & 3/8" DRIVE STANDARD ANVIL IMPACT WRENCHES

- **MOST POWERFUL 1/2" IMPACT WRENCH:** 1,000 ft./lb. fastening & 1,400 ft./lb. nut busting torque
- **MOST POWERFUL 3/8" IMPACT WRENCH:** 600 ft./lb. nut-busting torque
- Over 60% longer 3/8" anvil life than cordless competitor
- **MOST COMPACT HIGH TORQUE IN THE INDUSTRY:** Up to 0.7" shorter length than the competition
- Redlink plus intelligence prevents damage to the tool and battery due to overloading or overheating

CORDLESS 1/2" DRIVE STUBBY IMPACT WRENCH KIT

- **MOST COMPACT:** 5.1" in length
- 100 ft./lb. breakaway torque
- 4-mode drive control
- Auto shut-off mode reduces over fastening and increases productivity
- One of 90+ tools on the M12 system

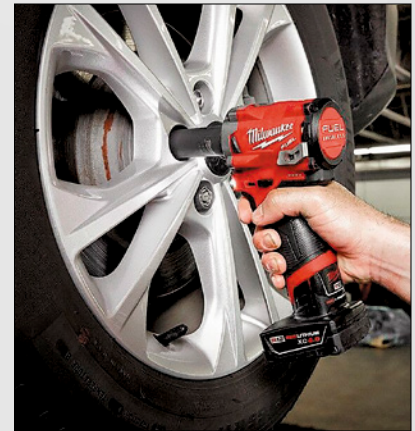

The Cordless 1/2" Drive Stubby Impact Wrench in use.



PART OF THE
M18™
SYSTEM

153-99322

OVER 60%
LONGER 3/8"
ANVIL LIFE

MOST
COMPACT
HIGH
TORQUE



PART OF THE
M12™
SYSTEM

153-55522

ASCOT NO.	MFG. NO.	DESCRIPTION
153-99322	2993-22	2-Piece Cordless Tool Kit: 1/2" & 3/8" Drive Standard Anvil Impact Wrenches

ASCOT NO.	MFG. NO.	DESCRIPTION
153-55522	2555-22	Cordless 1/2" Drive Stubby Impact Wrench Kit

AIR TOOLS // MILWAUKEE AIR TOOLS

➔ Cordless 1/4" & 3/8" Ratchet Tool Kits



Milwaukee Power Tools (cont.)

CORDLESS 1/4" RATCHET TOOL KIT

▪ **MOST POWERFUL:** Delivers industry leading torque output of up to 40 ft./lb. ▪ **MOST COMPACT:** Up to 20% smaller head size ▪ **MOST DURABLE:** Worlds 1st brushless ratchet provides 2x longer motor life ▪ Best-in class torque to head size ratio ▪ Premium metal components for longer durability



The Cordless 1/4" Ratchet Tool in use.

CORDLESS 3/8" RATCHET TOOL KIT

▪ **MOST POWERFUL:** Delivers industry leading torque output of up to 40 ft./lb. ▪ **MOST COMPACT:** Up to 20% smaller head size ▪ **MOST DURABLE:** Worlds 1st brushless ratchet provides 2x longer motor life ▪ Best-in class torque to head size ratio ▪ Premium metal components for longer durability



The Cordless 1/4" Ratchet Tool in use.

AIR TOOLS // MILWAUKEE AIR TOOLS



ASCOT NO.	MFG. NO.	DESCRIPTION
172-55621	2556-21	Cordless 1/4" Ratchet Tool Kit

ASCOT NO.	MFG. NO.	DESCRIPTION
172-55721	2557-21	Cordless 3/8" Ratchet Tool Kit



➔ M18 Lithium Battery, M18 Lithium Battery Pack, M12 Lithium Battery

M18 LITHIUM HIGH OUTPUT BATTERY

- **REDLINK™ INTELLIGENCE:** Our battery circuitry provides optimized performance and overload protection using total system communication between tool, battery and charger
- **BEST-IN-CLASS CONSTRUCTION:** Offers long-lasting performance and the best protection against jobsite, weather and environmental conditions
- **FUEL GAUGE ONBOARD:** Displays remaining run-time
- **VERSATILITY:** Powers all 175+ M18™ cordless solutions
- Compatible with all M18™ tools
- **2 year battery warranty**

M18 LITHIUM 5.0AH BATTERY PACK

- **REDLINK™ INTELLIGENCE:** Provides optimized performance and overload protection using total system communication between tool, battery and charger
- **BEST-IN-CLASS CONSTRUCTION:** Offers long-lasting performance and durability
- **FUEL GAUGE ONBOARD:** Displays remaining runtime for less downtime on the job
- **ALL-WEATHER PERFORMANCE:** Delivers fade free power in extreme jobsite conditions
- **VERSATILITY:** Powers more than 175+ Milwaukee® M18™ cordless power tools
- Ground transport only

M12 LITHIUM 3.0 COMPACT BATTERY

- **REDLINK™ INTELLIGENCE:** Provides optimized performance and overload protection using total system communication between tool, battery and charger
- **BEST-IN-CLASS CONSTRUCTION:** Offers long-lasting performance and durability
- **ALL-WEATHER PERFORMANCE:** Delivers fade-free power in extreme job site conditions
- **VERSATILITY:** Powers 70+ Milwaukee M12 cordless solutions



345-11835

PART OF THE
M18™
SYSTEM

FUEL GAUGE
ONBOARD

2-YEAR
BATTERY
WARRANTY

FUEL GAUGE
ONBOARD

PART OF THE
M18™
SYSTEM



345-11850

PART OF THE
M12™
SYSTEM



345-12430

ASCOT NO.	MFG. NO.	DESCRIPTION
345-11835	48-11-1835	M18 Lithium High Output Battery

ASCOT NO.	MFG. NO.	DESCRIPTION
345-11850	48-11-1850	M18 Lithium 5.0AH Battery Pack

ASCOT NO.	MFG. NO.	DESCRIPTION
345-12430	48-11-2430	M12 Lithium 3.0 Compact Battery

AIR TOOLS // MILWAUKEE AIR TOOLS

→ Air Tool Lubricants, Air Tool Conditioner

Air Tool Lubricants & Conditioner

AIR TOOLS // AIR TOOL LUBRICANTS & CONDITIONER

BLASTER AIR TOOL CONDITIONER

- **APPLICATIONS:** Thoroughly cleans internal pneumatic tool parts, restoring them to peak performance and prolonging tool life
- Breaks loose deposits that create friction and impede smooth operation
- Provides long-lasting lubrication
- Protects tools from freezing down to -25°F
- **12 cans per case**

ASCOT NO.	MFG. NO.	DESCRIPTION
181-00404	16-ATL	Blaster Air Tool Conditioner - 16 Oz.
181-01404	ATC-TS	Blaster Air Tool Conditioner - 3.5 Oz. Aerosol



181-00404

181-01404

SUPER RED PNEUMATIC AIR TOOL LUBRICANT

- **APPLICATIONS:** Dissolves gum & varnish formation
- Prevents gum & varnish formation
- Ensures smoother starts
- Special rust & oxidation inhibitor
- Clean and free running
- **12 bottles per case**

DISSOLVES GUM & VARNISH

ENSURES SMOOTHER STARTS



181-00406

ASCOT NO.	MFG. NO.	DESCRIPTION
181-00406	0406	Super Red Pneumatic Air Tool Oil, 32 Oz.

BLASTER AIR TOOL OIL/LUBE

- **APPLICATIONS:** Provides lubrication & prolongs tool life
- Improves tool performance
- Formulated for use with in-line oilers
- **12 cans per case**

PROLONGS TOOL LIFE



181-00016

ASCOT NO.	MFG. NO.	DESCRIPTION
181-00016	16-ATL	Blaster Air Tool Oil/Lube - 16 Oz.

KILFROST AIR TOOL OIL

- **Use KILFROST when the temperature drops below 45 degrees F**
- Apply directly into air inlet of tool
- Do not mix with other air tool lubricant
- Absorbs moisture, de-ices frozen tools and keeps tools working to -60 degrees F
- 16 Oz. with squirt spout
- **12 per case**

ABSORBS MOISTURE

DE-ICES FROZEN TOOLS



181-84581

ASCOT NO.	MFG. NO.	DESCRIPTION
181-84581	KILFROST-PINT-CASE	Kilfrost Air Tool Oil, 16 Oz.

MARVEL AIR TOOL OIL

- **APPLICATIONS:** Specially formulated for use in all piston type rotary air tools and in-line air lubricators
- Prevents rust formation while providing positive lubrication for smooth starting and longer tool life
- Assures maximum performance by dissolving gum and sludge
- **6 bottles per case**



181-00085

ASCOT NO.	MFG. NO.	DESCRIPTION
181-00085	MM085	Marvel Air Tool Oil, 32 Oz.

Impact Wrenches (IR)



QUICK REFERENCE CHART

IR No.	Ascot No.	Sq. Drive	Std. Bolt Size	Net Weight (lb.)	Average Air Cons. (CFM)	Air Inlet (NPTF)	Min. Hose Size	Working Torque Range (ft./lb.)	Max. Torque (ft./lb.)
IR-212	152-00212	3/8"	7/16"	2.89	2.5	1/4"	3/8"	20-150	180
IR-231HA	152-00231	1/2"	9/16"	5.8	4.2	1/4"	3/8"	25-350	590
IR-2115TIMAX	152-02115	3/8"	7/16"	2-1/2	4	1/4"	3/8"	25-230	250
IR-244A	153-00244	1/2"	9/16"	6	4.2	1/4"	3/8"	40-350	500
IR-2235TIMAX	153-02235	1/2"	9/16"	4.6	6	1/4"	3/8"	75-650	900 (980 rev)
IR-2235QTIMAX	153-32235	1/2"	9/16"	4.7	6	1/4"	3/8"	75-650	870 (930 rev)
IR-2135QXPA	153-22135	1/2"	9/16"	4	6	1/4"	3/8"	50-600	700 (780 rev)
IR-259	154-00259	3/4"	7/8"	8.8	6	3/8"	3/8"	200-800	1050
IR-261	154-00261	3/4"	1"	13.25	9.5	3/8"	1/2"	200-600	1100
IR-2145QiMAX	154-02145	3/4"	1"	7.4	8.5	3/8"	1/2"	200-900	1250 (1350 rev)
IR-271	155-00271	1"	1-1/4"	12.5	9.5	3/8"	1/2"	100-750	1200
IR-285B	155-00285	1"	1-1/4"	27-1/3	10	1/2"	1/2"	100-1000	1600
IR-290	155-00290	1"	1-1/4"	19-3/4	10	1/2"	1/2"	150-1000	1600
IR-293	155-00293	1"	1-3/8"	22-7/8	12	1/2"	1/2"	1000-1600	2000
IR-295	155-00295	1"	1-1/4"	22	10	3/8"	1/2"	100-1000	1450
IR-2161XP	155-02161	1"	1"	11.3	10	3/8"	1/2"	300-1000	1250
IR-2850MAX	155-02850	1"	1-1/4"	19- 7/16	14	1/2"	1/2"	300-1600	2000

AIR TOOLS // IMPACT WRENCHES (IR)

3/8" SUPER DUTY AIR IMPACT WRENCH

- Titanium hammer case ▪ 280 ft./lb. of torque will remove even the toughest nuts and bolts
- **APPLICATIONS:** Transmissions, brakes, exhaust, body repair and underhood



152-02115

ASCOT NO.	MFG. NO.	DESCRIPTION
152-02115	IR-2115TIMAX	3/8" Super Duty Air Impact Wrench

3/8" SUPER DUTY AIR IMPACT WRENCH

- Tremendous power and longer life
- **APPLICATIONS:** Popular choice of professional mechanics for under car, under hood and bench work ▪ Handle exhaust directs air away from work
- **TORQUE RANGE:** 20-150 ft./lb., 180 max.



152-00212

ASCOT NO.	MFG. NO.	DESCRIPTION
152-00212	IR-212	3/8" Super Duty Air Impact Wrench



Impact Wrenches (IR)

1/2" Super Duty Air Impact Wrench

- Most popular tool in its class
- Offers the sheer power and performance features to **tackle the toughest of jobs**
- Durable and economical
- **TORQUE RANGE:** 25-350 ft./lb.



153-00231

ASCOT NO.	MFG. NO.	DESCRIPTION
153-00231	IR-231HA	Standard Anvil
153-02312	IR-231HA-2	Extended Anvil

1/2" SUPER DUTY AIR IMPACT WRENCH

- **APPLICATIONS:** For tire-changing, shock and spring work, front-end work and other heavy automotive and truck work
- Pumps out 500 ft./lb. of torque at a free speed of 7,000 RPM
- IR-244A-2 with a two-inch extended anvil for use with flip sockets



153-00244

ASCOT NO.	MFG. NO.	DESCRIPTION
153-00244	IR-244A	Standard Anvil
153-02442	IR-244A-2	Extended Anvil

1/2" SUPER DUTY AIR IMPACT WRENCH

- Punish the toughest bolts with **780 ft./lb. of max reverse torque and 1,100 ft./lb. of nut-busting torque, all powered by Ingersoll Rand's finely tuned motor and twin-hammer impact mechanism**
- At only 4.3 pounds, the 2135QXPA is as light as it is powerful so your hand tires less, letting you get more work done
- Ingersoll Rand's Quiet Technology reduces the sound of the tool, sparing your ears without sacrificing a single ounce of power



153-32135

ASCOT NO.	MFG. NO.	DESCRIPTION
153-22135	IR-2135QXPA	Standard Anvil
153-32135	IR-2135QXPA-2	Extended Anvil

1/2" ULTRA DUTY TITANIUM AIR IMPACT WRENCH

- Titanium weighs less and provides greater durability
- Enhanced Twin Hammer mechanism for fast removal of frozen bolts
- Push button forward/reverse controls for one-handed operation
- **TORQUE RANGE:** 50-600 ft./lb., 625 ft./lb. max (forward), 700 ft./lb. max (reverse)



153-12235

ASCOT NO.	MFG. NO.	DESCRIPTION
153-02235	IR-2235TiMAX	Standard Anvil
153-12235	IR-2235TiMAX-2	2" Extended Anvil
153-32235	IR-2235QTiMAX	Quiet Version
153-22235	IR-2235QTiMAX-2	Quiet Version with 2" Extended Anvil

3/4" SUPER DUTY AIR IMPACT WRENCH

- Non-biased motor delivers 1,050 ft./lb. of maximum torque in both forward and reverse
- Two power settings in forward and reverse
- Variable speed trigger
- Lighter than other 3/4" impacts in its class
- Handle-vented exhaust directs air away from the operator
- Silenced exhaust reduces tool noise while in use



154-00259

ASCOT NO.	MFG. NO.	DESCRIPTION
154-00259	IR-259	3/4" Super Duty Air Impact Wrench

AIR TOOLS // IMPACT WRENCHES (IR)



➔ 3/4" & 1" Impact Wrenches

3/4" SUPER DUTY AIR IMPACT WRENCH

▪ Powerful 3/4" wrench ▪ Combines compact size with high output ▪ Ideal for everything from spring work to pinion nut and track pad removal and major engine teardowns ▪ Jumbo hammer mechanism delivers up to 1,100 ft./lb. of torque smoothly, with less vibration



154-00261

ASCOT NO.	MFG. NO.	DESCRIPTION
154-00261	IR-261	Standard Anvil
154-02613	IR-261-3	3" Extended Anvil
154-02616	IR-261-6	6" Extended Anvil

1" HEAVY DUTY AIR IMPACT WRENCH

▪ Improved 1" drive tool perfect for truck and heavy equipment maintenance ▪ Offers power and convenience at an affordable price ▪ Compact, lightweight and perfect for working on suspension components ▪ **TORQUE RANGE:** 100-1000 ft./lb.



155-00295

ASCOT NO.	MFG. NO.	DESCRIPTION
155-00295	IR-295	Standard Anvil
156-02951	IR-295-S	#5 Spline Drive

3/4" MAXIMUM IMPACT AIR IMPACT WRENCH

▪ 3/4" Maximum Impact Air Impact Wrench ▪ 1350 ft./lb. maximum reverse torque from a tool that weighs just 7.4 lb. and is compact enough to access tight spaces ▪ Built to last and designed to withstand tough use in rugged environments ▪ An air motor that's 16% more efficient than its predecessor and an easy-to-clean inlet screen means less downtime, better tool performance, and less money spent on compressed air ▪ **TORQUE RANGE:** 200-900 ft./lb.



154-22145

ASCOT NO.	MFG. NO.	DESCRIPTION
154-12145	IR-2145QIMAX	Standard Anvil
154-22145	IR-2145QIMAX-3	3" Extended Anvil
154-32145	IR-2145QIMAX-6	6" Extended Anvil

3/4" ULTRA DUTY AIR IMPACT WRENCH

▪ Offers all of the ergonomic, power and durability enhancing features as the IR-2161 but with a 6" extended anvil for those hard to reach applications ▪ Jumbo hammer mechanism ▪ Up to 1,200 ft./lb. of torque ▪ Trouble-free, longer performance aided by the pressure-feed lube system ▪ Compact and only 7-5/8" long ▪ Handle exhaust



154-21617

ASCOT NO.	MFG. NO.	DESCRIPTION
154-21617	IR-2161XP-6	3/4" Ultra Duty Air Impact Wrench

1" D-HANDLE IMPACT WRENCH

▪ **SOLID STEEL IMPACT MECHANISM:** Deliver 2,100 ft./lb. of torque ▪ **HIGHLY ENGINEERED DESIGN:** Delivers the power you need over the life of the tool ▪ **STEEL CORE DESIGN:** Nothing's been proven to last longer ▪ **CHEMICAL RESISTANT HOUSING & STEEL CORE:** Stands up to drops and harsh work environments ▪ **LIGHTWEIGHT:** 25% lighter than the industry's leading 1" wrench ▪ **360° ADJUSTABLE HANDLE:** The side handle rotates fully around the tool as the job demands ▪ **SWIVEL HOSE CONNECTION:** Keeps cords from getting tangled so you can move freely around the garage ▪ **6" ANVIL EXTENSION:** Increases accessibility in hard to reach places



155-02850



155-28506

ASCOT NO.	MFG. NO.	DESCRIPTION
155-02850	IR-2850MAX	Standard Anvil
155-28506	IR-2850MAX-6	Extended Anvil

AIR TOOLS // IMPACT WRENCHES (IR)

➔ 1" Impact Wrenches



Impact Wrenches (IR) (cont.)

1" Heavy Duty Air Impact Wrench



155-02856

- Combines exceptional power, durability and operator convenience
- Delivers 1450 ft./lb. of maximum torque at 90 psi (1770 ft./lb. max torque at 120 psi) with a 5000 RPM free speed and four-position regulator 360° swivel inlet
- Chemical resistant boot
- Available in 6" extended anvil and 6" extended #5 spline anvil A1:O89 or high production truck tire changing

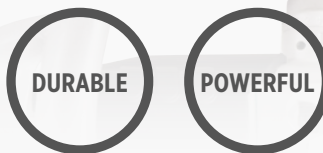

ASCOT NO.	MFG. NO.	DESCRIPTION
155-28560	IR-285B	Standard Anvil
155-02856	IR-285B-6	6" Extended Anvil
156-28566	IR-285BS-6	#5 Spline Super Duty Anvil

AIR TOOLS // IMPACT WRENCHES (IR)

1" SUPER DUTY AIR IMPACT WRENCH



155-00280

- 1" drive wrench with 1,000 ft./lb. torque to handle tough jobs in cramped spaces
- Built-in pressure-feed lube system, adjustable side handle and built-in oil reservoir that provides continuous misting of the air motor
- Available in 6" extended anvil and 6" extended #5 spline drive anvil for high production truck tire changing

ASCOT NO.	MFG. NO.	DESCRIPTION
155-00280	IR-280	Standard Anvil
155-02806	IR-280-6	6" Extended Anvil
156-28006	IR-280-S6	#5 Spline Super Duty Anvil

1" SUPER DUTY AIR IMPACT WRENCH



155-00290

- Designed for getting into cramped spaces with three-way adjustable handle
- Ideal for spring work, tractor pads, bus maintenance and off-road/farm equipment
- **TORQUE RANGE:** 150-1000 ft./lb. (1600 maximum)

ASCOT NO.	MFG. NO.	DESCRIPTION
155-00290	IR-290	Standard Anvil
156-02901	IR-290-S	#5 Spline

1" ULTRA DUTY AIR IMPACT WRENCH



155-00293

- **APPLICATIONS:** Most powerful 1" wrench for spring work, tractor pads, bus maintenance and off-road/farm equipment
- **MAXIMUM TORQUE:** 2000 ft./lb.

ASCOT NO.	MFG. NO.	DESCRIPTION
155-00293	IR-293	Standard Anvil
156-02931	IR-293-S	#5 Spline Drive

1" ULTRA DUTY AIR IMPACT WRENCH



155-21710

- High power-to-weight ratio
- Full power reverse
- 3-position power regulator
- 360° swivel inlet
- **MAXIMUM TORQUE:** 1250 ft./lb.



ASCOT NO.	MFG. NO.	DESCRIPTION
155-21710	IR-2171XP	Standard Anvil



Cordless Impact Wrench (IR)

1/2" IQv20 Cordless Impact Wrench

- 780 ft./lb. reverse torque and **1100 ft./lb. nut-busting torque** from a tool weighing just 6.8 lb., best power to weight ratio in its class.
- **High-efficiency rare earth magnet motor, high-capacity variable speed trigger, all-metal drive train, and metal-reinforced housing** enable this tool to stand up to the toughest jobs.
- Optimized balance combined with an **ergonomic handle** and **soft touch over-molded grip** provide increased comfort in extended use.
- **Long life 20V lithium-ion battery** delivers high-charge capacity and low internal impedance for maximum power delivery and run time.
- **Intelligent battery management system (BMS)** provides power-level and flow-rate control from the battery to the switch to the motor for optimum efficiency.



AIR TOOLS // IMPACT WRENCHES (IR)

ASCOT NO.	MODEL	BATTERIES INCLUDED	DRIVE SIZE	ANVIL	MAX TORQUE FT./LB.	FREE SPEED (RPM)	BPM	LENGTH IN.	WEIGHT	VIBRATION (M/S ²)	SOUND DBA
153-71521	W7152	1	1/2" (Socket Retaining Ring)	Standard	1000 (1,360)	0-1900	2450	6.7	8.1 lb.	7.6 (3.4)	95.7
153-72522	W7252	1	1/2" (Socket Retaining Ring, 2" Ext)	2" extended	1000 (1,360)	0-1900	2450	8.1	8.1 lb.	7.9 (3.6)	95.3



Air Hammers & Die Grinders (IR)

SUPER DUTY AIR HAMMER

▪ **APPLICATIONS:** For front-end and heavy exhaust work, riveting, king pin removal, bushing driving and bolt shearing ▪ Controls starting strokes precisely with an extra-sensitive tease throttle ▪ Super duty power, at up to 1,725 blows per minute ▪ **CHISEL SHANK DIAMETER:** .401"



SUPER DUTY POWER

159-00132

ASCOT NO.	MFG. NO.	DESCRIPTION
159-00132	IR-132	Super Duty Air Hammer

HEAVY DUTY ANGLE AIR DIE GRINDER

▪ For work in confined areas ▪ Features a right angle head ▪ **APPLICATIONS:** For grinding, porting, polishing, de-burring, breaking sharp edges ▪ Self-locking throttle lever ▪ Positive grip 1/4" capacity collet chuck



FOR WORK IN CONFINED AREAS

157-00302

ASCOT NO.	MFG. NO.	DESCRIPTION
157-00302	IR-302B	Heavy Duty Angle Air Die Grinder

NEEDLE SCALER

▪ **APPLICATIONS:** For surface preparation work involving the cleaning or removal of paint, rust, dirt or weld slag ▪ Durable, dependable and economical



FOR SURFACE PREP AND CLEANING

DURABLE & ECONOMICAL

157-00125

ASCOT NO.	MFG. NO.	DESCRIPTION
157-00125	IR-125	Needle Scaler

HEAVY DUTY AIR DIE GRINDER

▪ **APPLICATIONS:** Designed for porting, light weld grinding and breaking sharp edges ▪ 25,000 RPM ▪ Self-locking throttle lever ▪ Positive grip 1/4" capacity collet chuck with two collet wrenches



ASCOT NO.	MFG. NO.	DESCRIPTION
157-00308	IR-308B	Heavy Duty Air Die Grinder

157-00308

AIR HAMMER KITS

▪ Five-piece chisel set in a plastic pouch with .401" shank diameters ▪ **INCLUDES:** Edging Tool, Tail Pipe Cutter, Straight Chisel, Cutting Chisel and Pouch



FIVE-PIECE CHISEL SET

171-01161

ASCOT NO.	MFG. NO.	DESCRIPTION
171-01151	IR-115K	IR-115 Air Hammer Kit
171-01161	IR-116K	IR-116 Air Hammer Kit
171-01171	IR-117K	IR-117 Air Hammer Kit

SUPER DUTY MINI AIR DIE GRINDER

▪ **APPLICATIONS:** For grinding, edge-breaking, de-burring, porting and polishing ▪ Right-angle configuration ▪ Compact, lightweight and easy to handle



COMPACT & LIGHT IN WEIGHT

EASY TO HANDLE

157-00307

ASCOT NO.	MFG. NO.	DESCRIPTION
157-00307	IR-307B	Super Duty Mini Air Die Grinder

AIR TOOLS // GRINDERS, BUFFERS, SANDERS & DRILLS (IR)





Finishing Tools & Air Drills (IR)

QUICK REFERENCE CHART

IR No.	Ascot No.	Description
IR-301-2MK	157-03012	Surface Conditioning Kit
IR-311A	158-00311	Heavy Duty Dual Action Quiet Air Sander 6" Pad
IR-326	157-00326	Heavy Duty 2-7/8" Air Cut-Off Tool
IR-313A	157-00313	Heavy Duty Angle Air Sander 7" Pad
IR-317A	158-00317	Heavy Duty High Speed Air Sander 5" Pad
IR-319A	158-00319	Heavy Duty Vertical Air Sander 7" Pad

3/8" HEAVY DUTY AIR DRILL

- Planetary gear reduction balances the load on bearings and gears, increasing tool life
- Variable speed throttle makes starting holes easy
- Positive action trigger stop reduces maximum speed at any time



157-17802



ASCOT NO.	MFG. NO.	DESCRIPTION
157-07802	IR-7802A	Standard Air Drill
157-17802	IR-7802RA	Reversible Air Drill

1/2" HEAVY DUTY AIR DRILL

- APPLICATIONS:** Designed for drilling, hole sawing, cylinder honing and other jobs that call for a 1/2" size
- Industrial grade 1/2" chuck, ball and needle bearing construction and double reduction planetary gearing for longer life
- No-load speed of 500 RPM and auxiliary side handle



157-17803



ASCOT NO.	MFG. NO.	DESCRIPTION
157-07803	IR-7803A	Standard Air Drill
157-17803	IR-7803RA	Reversible Air Drill

HIGH SPEED TIRE BUFFER

- Lever style tease trigger with lock-off for easy operation
- Quick change chuck for easy buffing



157-00327

ASCOT NO.	MFG. NO.	DESCRIPTION
157-00327	IR-327	High Speed Tire Buffer

HEAVY DUTY AIR LOW SPEED TIRE BUFFER

- APPLICATIONS:** For quick work of patchwork and roughing up low areas for recapping, tire scuffing and cleaning tire moldings
- Free speed up to 3,000 RPM
- 1/2 HP motor



157-01327



ASCOT NO.	MFG. NO.	DESCRIPTION
157-01327	IR-327LS	Heavy Duty Air Low Speed Tire Buffer, includes Over Hose

AIR TOOLS // GRINDERS, BUFFERS, SANDERS & DRILLS (IR)



Finishing Tools & Air Drills (IR) (cont.)

HEAVY DUTY AIR ANGLE SANDER 7" PAD

▪ Heavy-duty motor handles tough jobs ▪ Lightweight at only 4.5 lb. (2.04 kg.) ▪ Ball Bearing construction for increased tool life ▪ **APPLICATIONS:** rouging body filler, removing rust, and smoothing welds



157-00313

ASCOT NO.	MFG. NO.	DESCRIPTION
157-00313	IR-313A	Heavy Duty Air Angle Sander 7" Pad

HEAVY DUTY DUAL ACTION QUIET AIR SANDER 6" PAD

▪ A built-in silencer muffles noise as you work ▪ **APPLICATIONS:** Quality sander used for feather edging, metal preparation and finish work on body filler



158-00311

ASCOT NO.	MFG. NO.	DESCRIPTION
158-00311	IR-311A	Heavy Duty Dual Action Quiet Air Sander 6" Pad

SURFACE CONDITIONING KIT

▪ **KIT INCLUDES:** IR301 1/4" angle head die grinder in a blow molded plastic case with two coarse and two medium grit 3" 3M Rolco™ surface conditioning pads, two coarse, two medium grit 2" 3M Rolco™ surface conditioning pads and a disc holder



IR301 1/4" Angle head Die Grinder



158-03012

ASCOT NO.	MFG. NO.	DESCRIPTION
158-03012	IR-301-2MK	Surface Conditioning Kit

AIR TOOLS // GRINDERS, BUFFERS, SANDERS & DRILLS (IR)



Air Tool Accessories

AIR TOOL LUBRICANTS



181-10510

ASCOT NO.	MFG. NO.	DESCRIPTION
181-10510	105-LBK1	4 Oz. IR 105 Grease, 4 oz. IR10 Oil & Grease Gun Head
181-10540	105-4T	(6) 4 oz. Tubes - IR 105 Grease Refills
181-11510	115-LBK1	4 oz. IR 115 Grease, 4 oz. IR10 Oil & Grease Gun Head
181-11540	115-4T	(6) 4 oz. Tubes - IR 115 Grease Refills
181-12228	R000A2-228	Grease Gun
328-10001	100-1	1 lb. Grease for Impact Wrenches

AIR TOOL COVERS

▪ Vinyl boots also absorb some of the tool vibration and protect air impact ratchets, wrenches and drills from external damage

IR TOOL NO.	KIT NO.	ASCOT TOOL NO.
212	212-Boot	176-20232
211	211-P32	176-21132
231C, 231HA-2	231-Boot	176-23122
2235	2235M-Boot	176-13532
244A, 244A-2	244-Boot	176-24432
261, 261-2, 271	261-Boot	176-26132
285B-6, 285BS-6, 285B	285-Boot	176-28532
259	259-Boot	176-25925
2135QXPA, 2135QXPA-2	2135M-Boot	176-21350

HAMMER MECHANISM TUNE-UP KIT

▪ **INCLUDES:** the anvil, hammer (or pins) and gaskets for the impact mechanism ▪ 110-TK1 includes only the cam ball, two anvil pins and anvil spring

IR TOOL NO.	KIT NO.	ASCOT TOOL NO.
231C, 244A	231-THK1	176-00231
231-2HA-2, 244A-2	231-THK2	178-01231
2235TIMAX	2235-THK1	178-02235
2135QXPA-2	2135-THK1	178-02335



178-02135

RETAINING RINGS

IR TOOL NO.	ASCOT TOOL NO.	DESCRIPTION
231-425A	175-31425	Socket Retainer for IR231, 231-2
RIA-159	175-01590	Retainer O-Ring for IR 231, 231-2
291-425	175-91425	Socket Retainer for IR-281, 285
291-426	175-81426	Retainer O-Ring for IR-281, 285

MOTOR TUNE-UP KITS

▪ **INCLUDES:** the vanes, gaskets and seals for a complete tune-up ▪ 231-TK3 also includes ball bearings

IR TOOL NO.	KIT NO.	ASCOT TOOL NO.
212	212-TK2	176-10212
231C, 231HA-2	231-TK3	176-10221
235	235-TK3	176-12313
244A, 244A-2	244-TK2	176-10244
261, 271	261-TK2	176-10261
280 Series	280-TK2	176-10280
7803A, 7803RA	7803-TK1	176-17803
285B-6	285B-TK1	176-10285
2235TIMAX	2235-TK1	176-22235
2135QXPA, 2135QXPA-2	2135-TK2	176-32135

IMPACT WRENCH ACCESSORIES

ASCOT NO.	MFG. NO.	DESCRIPTION
175-23142	IR 231-425	IR 1/2" Impact Wrench Retainer Clip
175-33104	231-Boot	Red Protective Boot for IR 231HA-2 Impact Wrenches
175-82651	H-082651	1" Impact Wrench Retainer Clip O-Ring
175-83071	P-08371	O-Ring for 1/2" Impact Wrench Retainer Clips



INDUSTRIAL STRENGTH SILICONE LUBRICANT

▪ Teflon™ fluoropolymer enhances performance
 ▪ Long-lasting lubrication
 ▪ Won't accumulate
 ▪ dust & dirt
 ▪ **QUANTITY:** 12 per case



328-00016

ASCOT NO.	MFG. NO.	DESCRIPTION
328-00016	16-SL	Blaster Silicone Lubricant - 11 Oz.

AIR TOOLS // AIR TOOL ACCESSORIES

→ Tool Caddy, Mobile Wheel Work Station, Tire Tool Station

Work Stations

A. TOOL CADDY TIRE TOOL STAND

▪ Provides easy and fast access to all those tools needed quickly when changing tires such as torque sockets, valve stem pullers, hub cap tools, air impact guns and torque sticks ▪ Reduces installation time ▪ Makes tire changing easier & work stations more organized ▪ Reduces the number of trips for the technician by having all tools needed at their fingertips ▪ **WEIGHT:** 35 lb.

ASCOT NO.	MFG. NO.	DESCRIPTION
319-50015	MTTS	Tool Caddy Tire Tool Stand

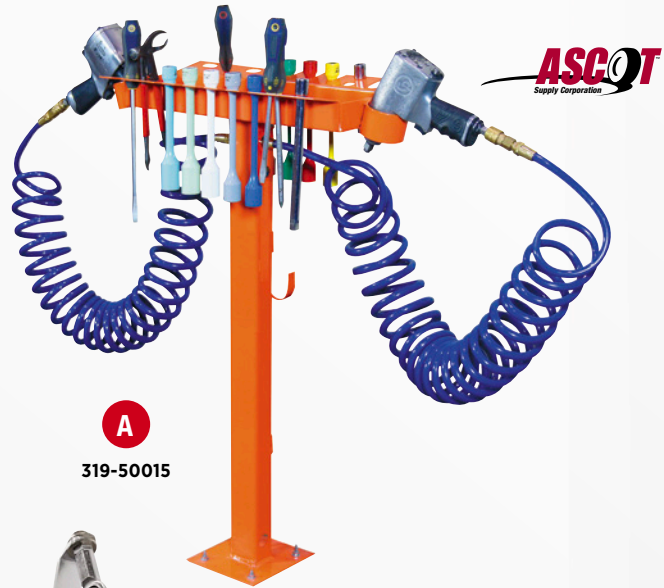

A

319-50015

B. MOBILE WHEEL WORK STATION

▪ Features gas-strut assisted boom that supports the weight of those heavy impact wrenches ▪ The suspended impact wrench is capable of rotating to the operator desired position ▪ Features side and rear storage compartments designed to organize sockets, tire irons, lubricants, hoses and various wheel parts ▪ Air wrench is supported and held in desired position ▪ Air wrench suspension boom allows for directional freedom and reduces damage

ASCOT NO.	MFG. NO.	DESCRIPTION
515-00555	WS-005	Mobile Wheel Work Station



B

515-00555

C. TIRE TOOL STATION

▪ Organize your tools ▪ Universal top tray with slots for torque sockets, etc. ▪ Dual cradles for impact guns, 1/4" airline connections ▪ INCLUDES: (2) 25' x 3/8" recoil hoses with 1/4" swivel fittings

ASCOT NO.	MFG. NO.	DESCRIPTION
515-02400	2400	Tire Tool Station



C

515-02400

AIR TOOLS // WORK STATIONS